

Współczesne znaki drogowe, skala 1:35

Znaki zakazu

Opracował Paweł Adamowicz (<http://pkprepo.net/>), 2010-2017, niektóre prawa zastrzeżone  CC BY-NC-ND

1cm

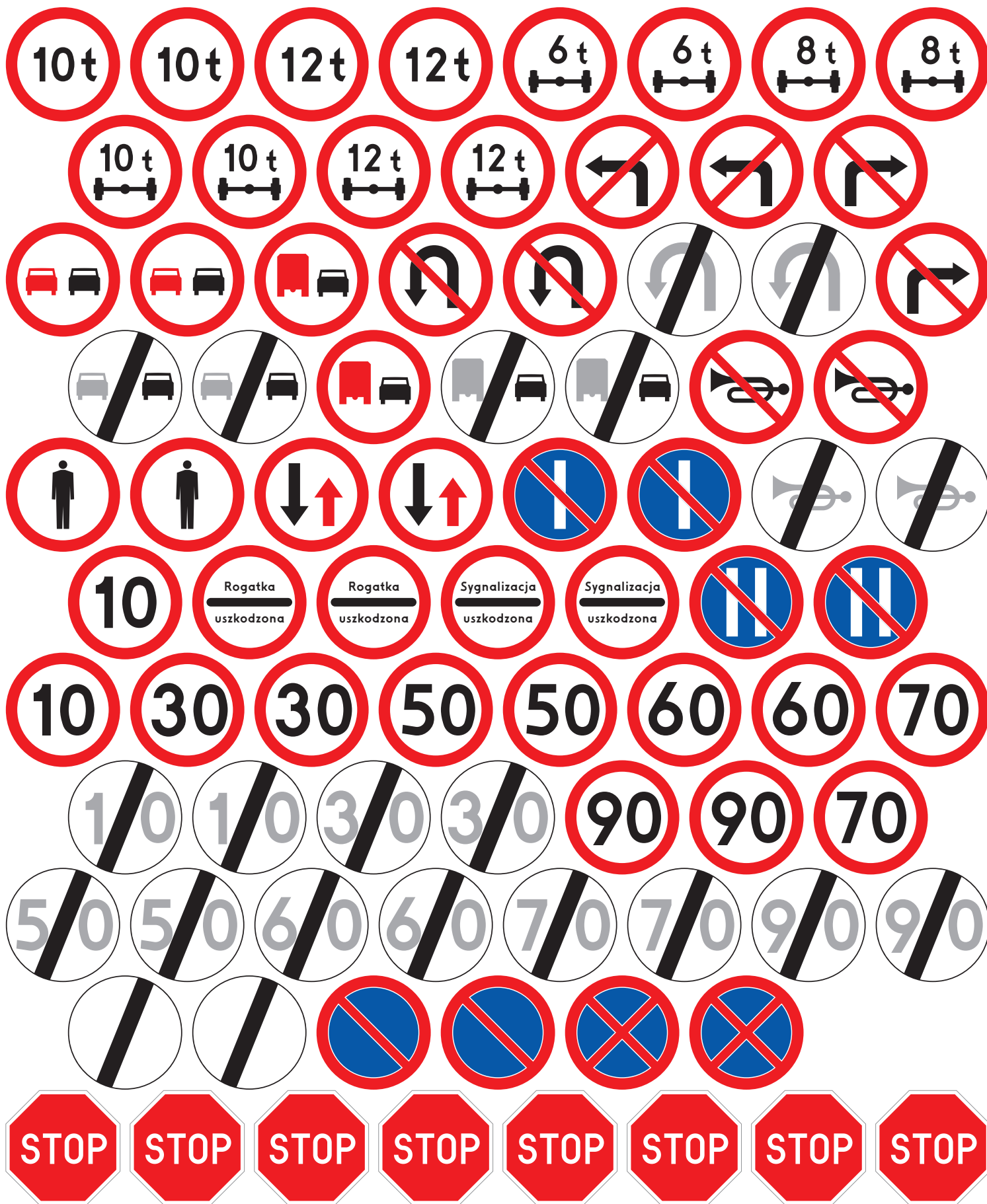

Współczesne znaki drogowe, skala 1:35

Znaki zakazu

Opracował Paweł Adamowicz (<http://pkprepo.net/>), 2010-2017, niektóre prawa zastrzeżone

1cm

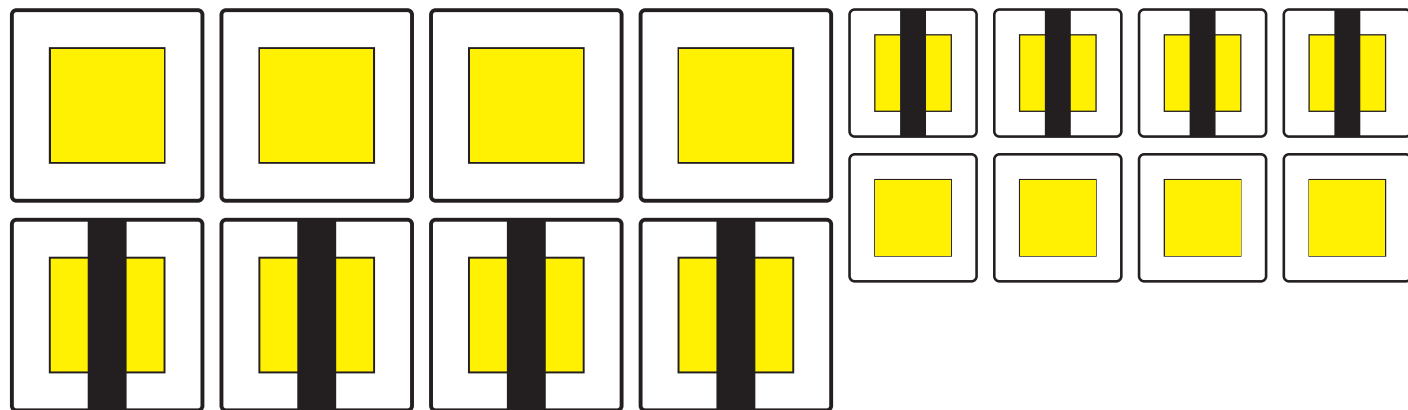
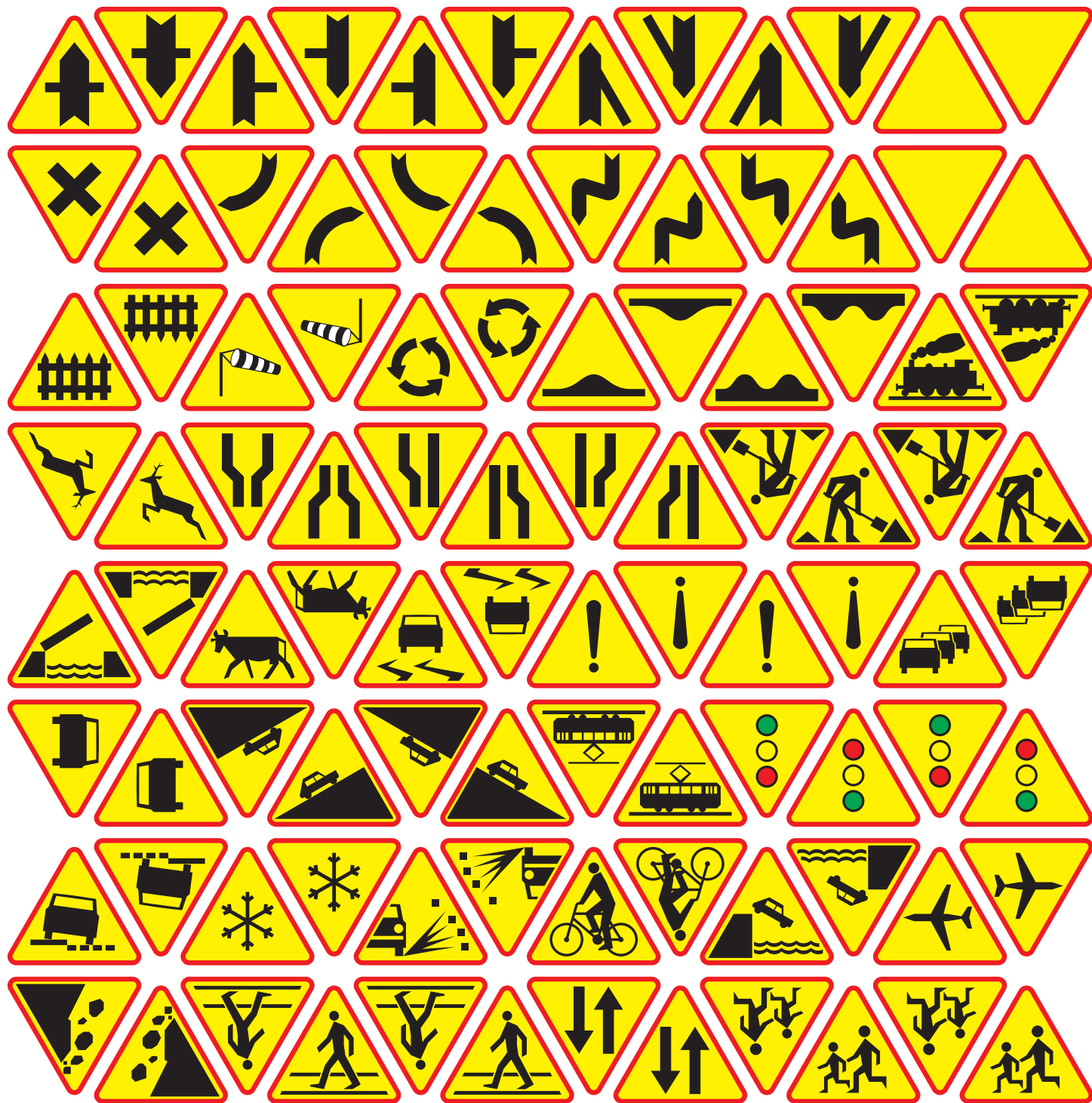

Współczesne znaki drogowe, skala 1:35

Znaki ostrzegawcze, znaki pierwszeństwa przejazdu (duży i mały)

Opracował Paweł Adamowicz (<http://pkprepo.net/>), 2010-2017, niektóre prawa zastrzeżone 

1cm

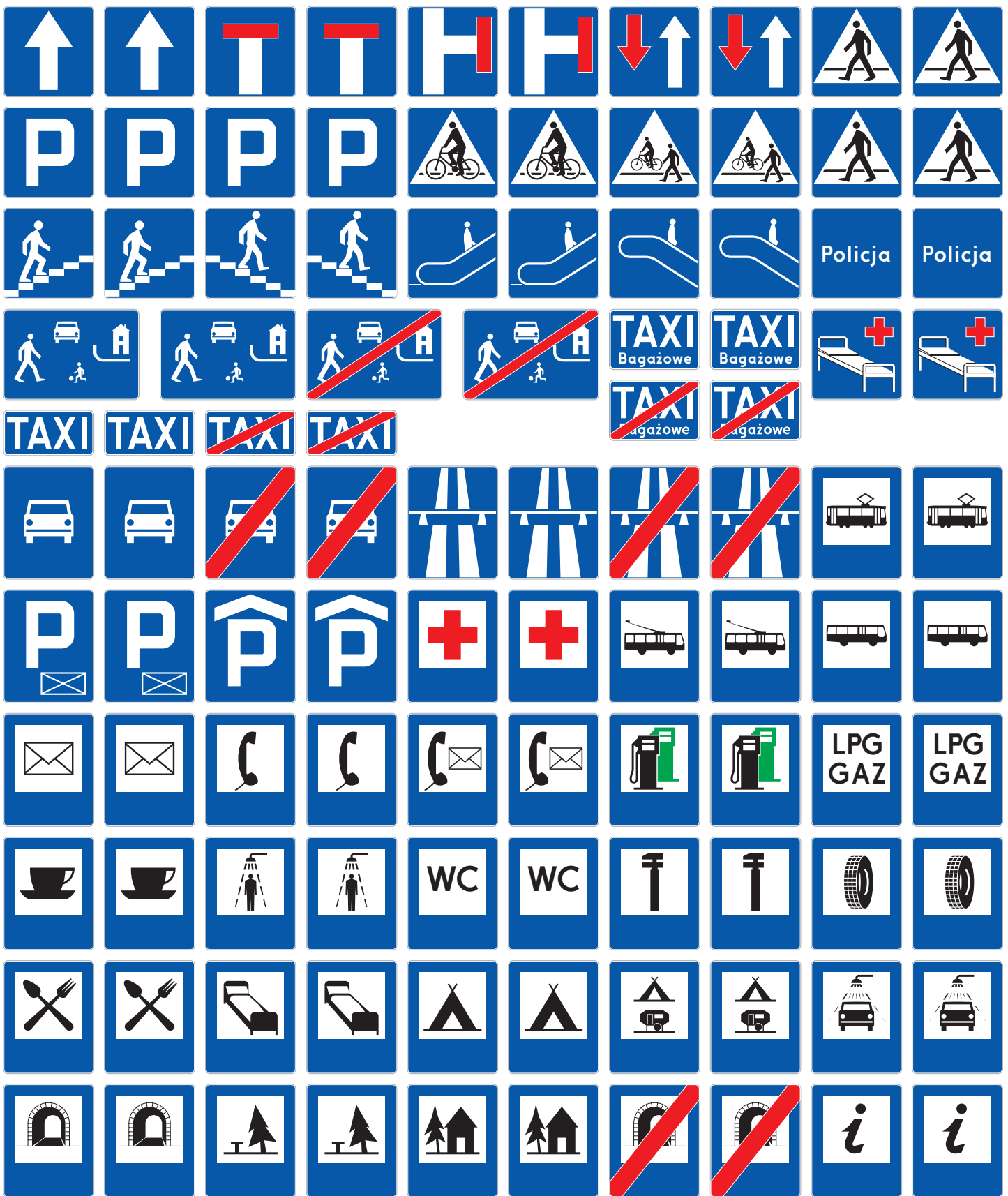

- | | | | | | | | | |
|---------------------------------|---------------------------------|-----------------------------------|-----------------------------------|--------------------------------------|--------------------------------------|-----------------|------------------|-----------------------------|
| Nie dotyczy mieszkańców posesji | Nie dotyczy mieszkańców posesji | Nie dotyczy pojazdów zaopatrzenia | Nie dotyczy pojazdów zaopatrzenia | Nie dotyczy pojazdów służb miejskich | Nie dotyczy pojazdów służb miejskich | Nie dotyczy PKS | Droga wewnętrzna | Droga wewnętrzna |
| Nie dotyczy MZK | Nie dotyczy MZK | Nie dotyczy MPK | Nie dotyczy MPK | Nie dotyczy TAXI | Nie dotyczy TAXI | Nie dotyczy PKS | Droga wewnętrzna | Droga wewnętrzna |

Współczesne znaki drogowe, skala 1:35

Znaki informacyjne, tabliczki uzupełniające

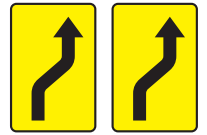
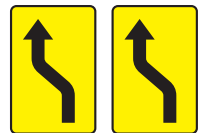
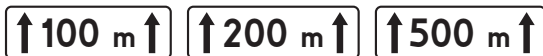
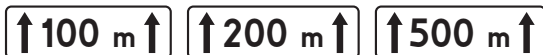
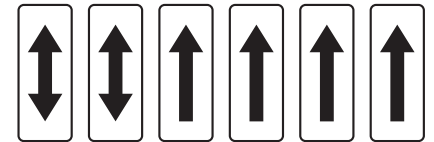
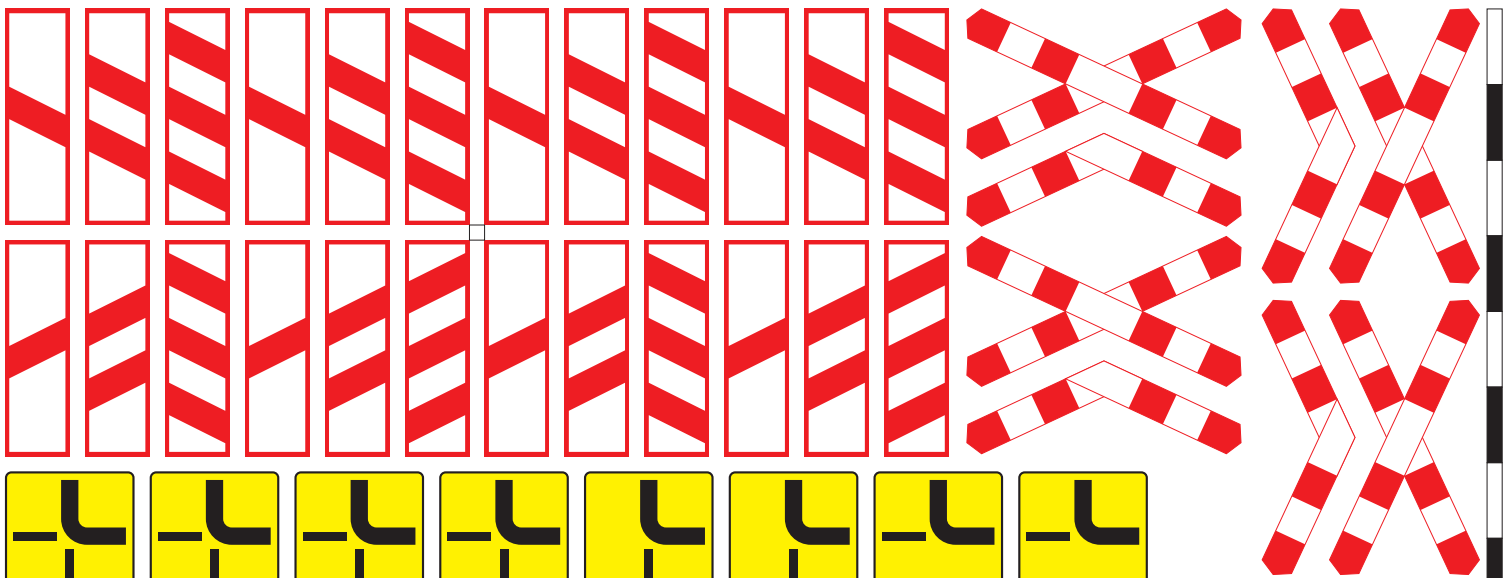

Współczesne znaki drogowe, skala 1:35

Tablice uzupełniające, oznakowanie przejazdu kolejowego

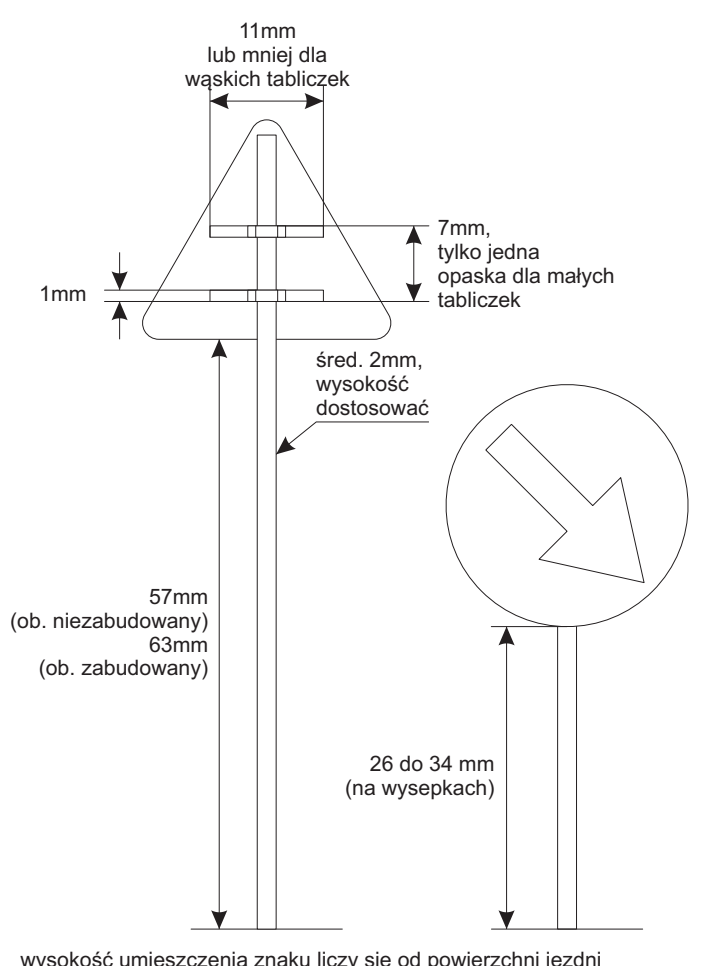
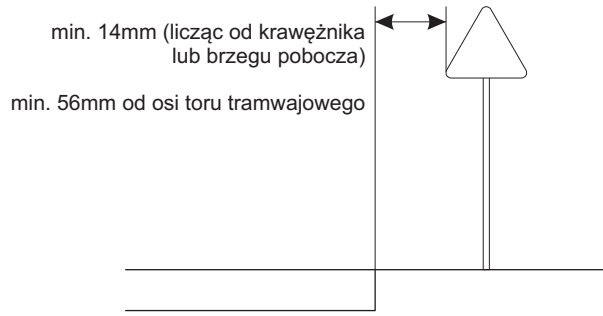
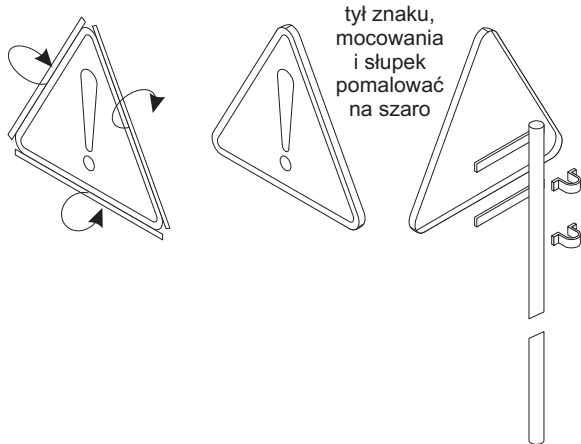

Współczesne znaki drogowe, skala 1:35

1cm