

Wskaźniki kolejowe PKP, 1959-2014, skala 1:45 (0)

1cm

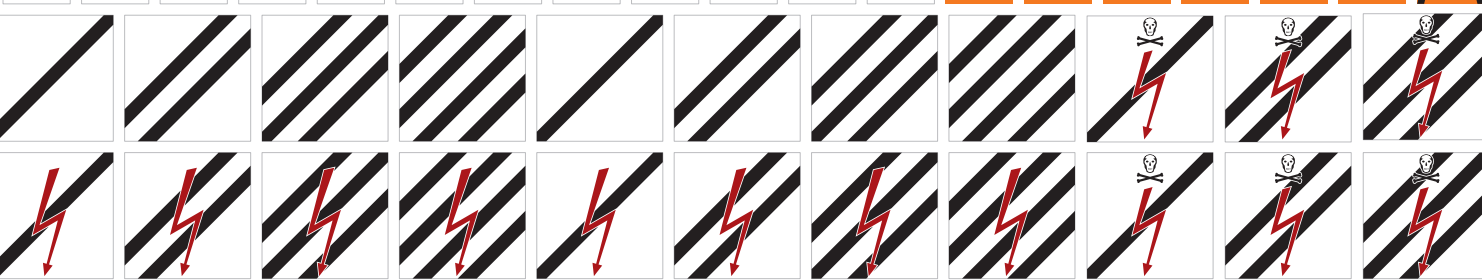

Wskaźniki kolejowe PKP, 1959-2014, skala 1:45 (0)

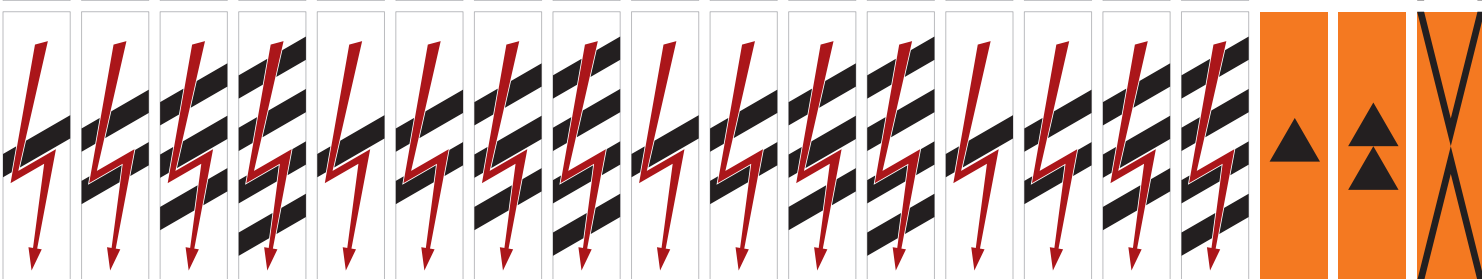
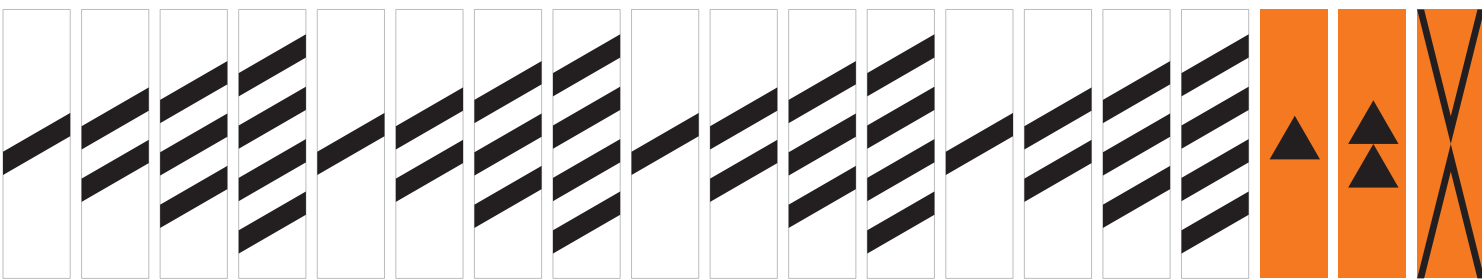
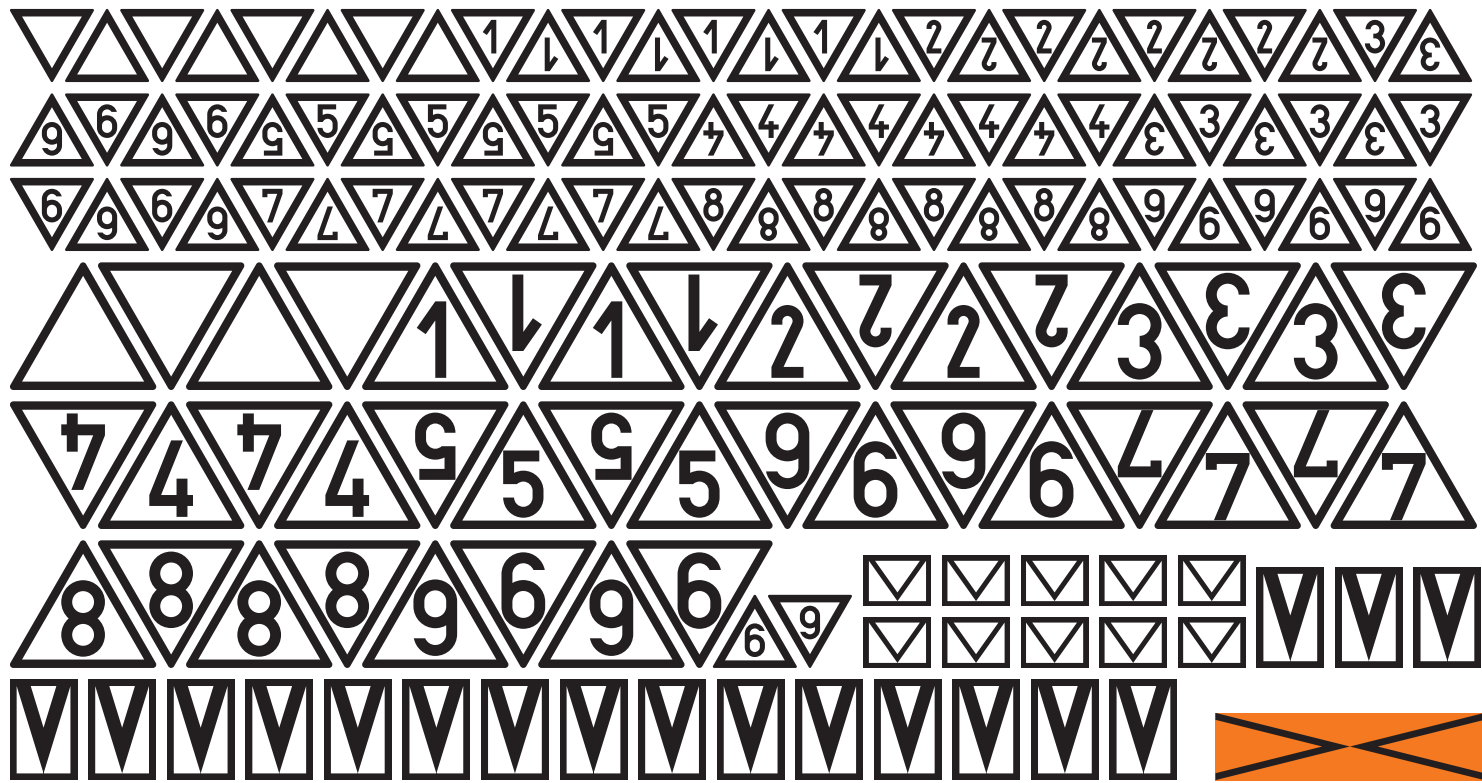
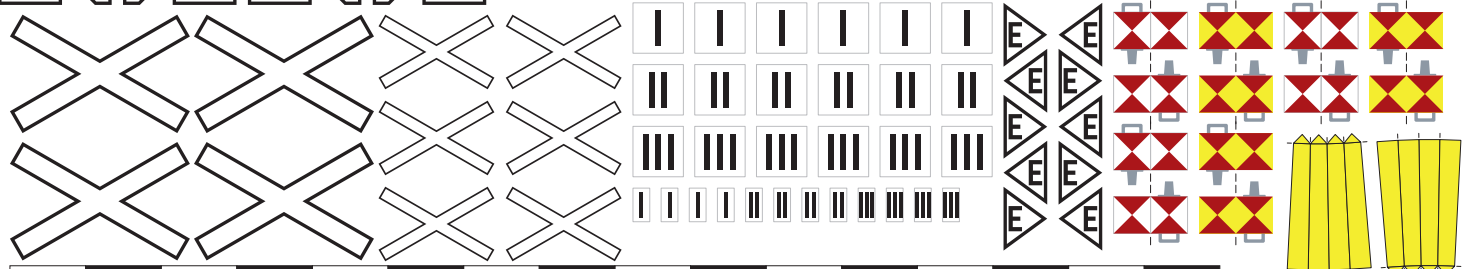
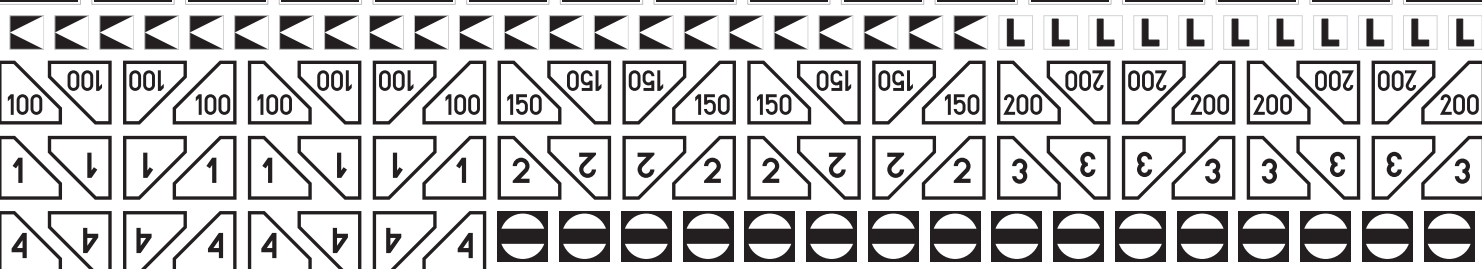
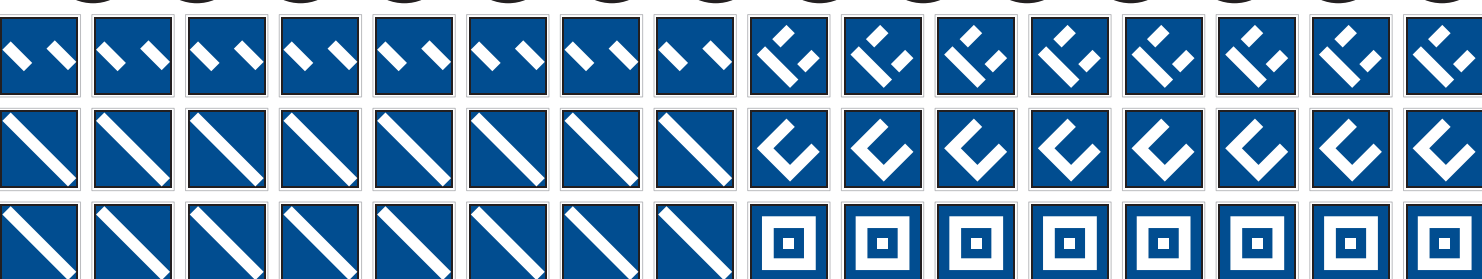
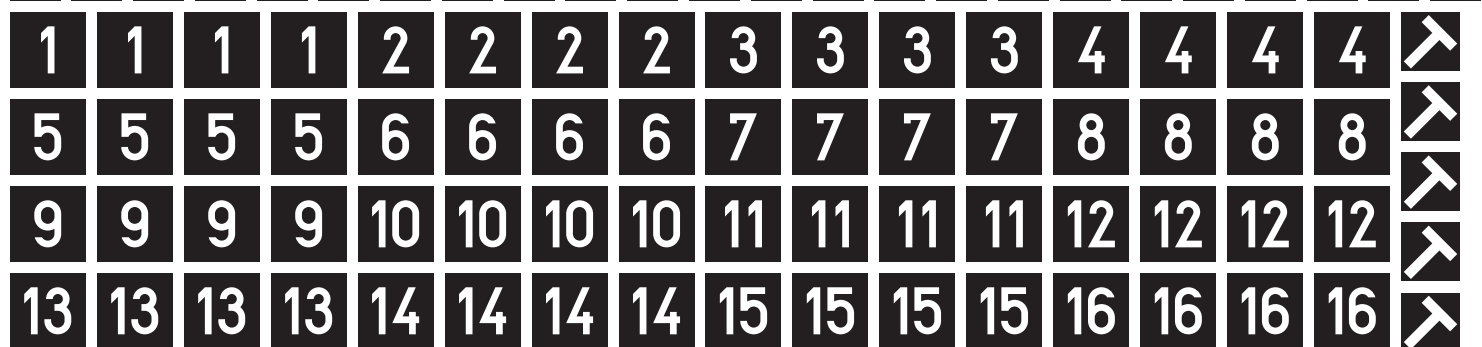
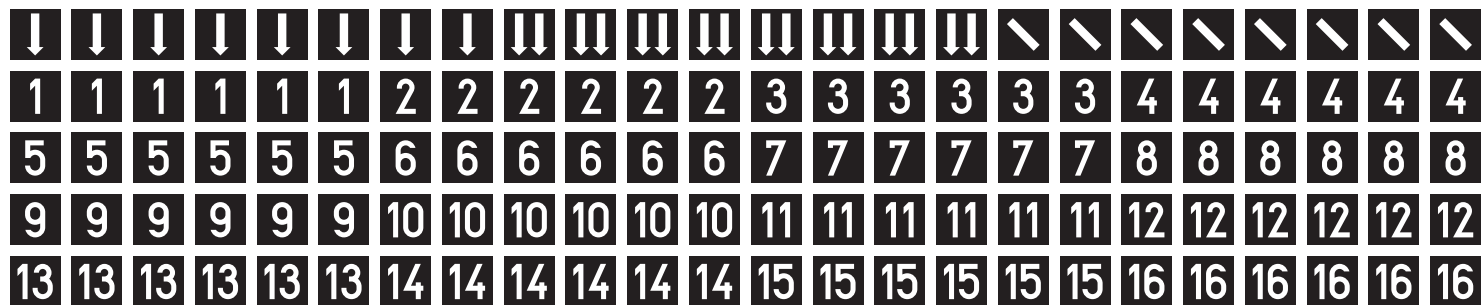
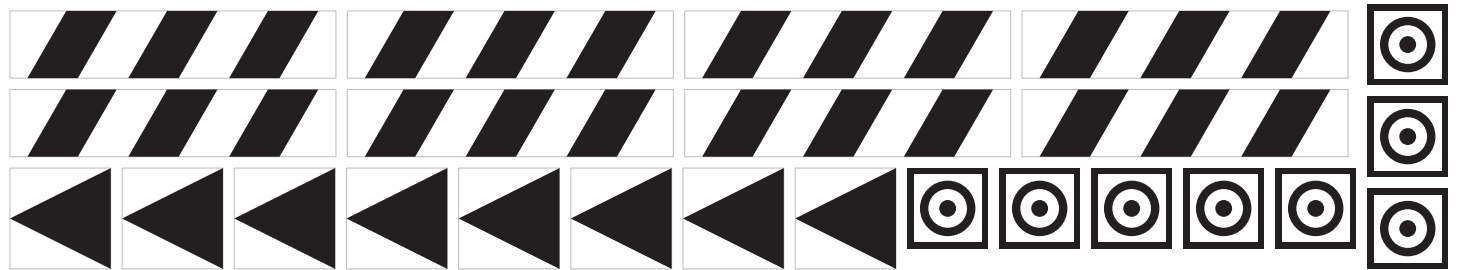

Wskaźniki kolejowe PKP, 1959-2014, skala 1:45 (0)

Sygnal D0

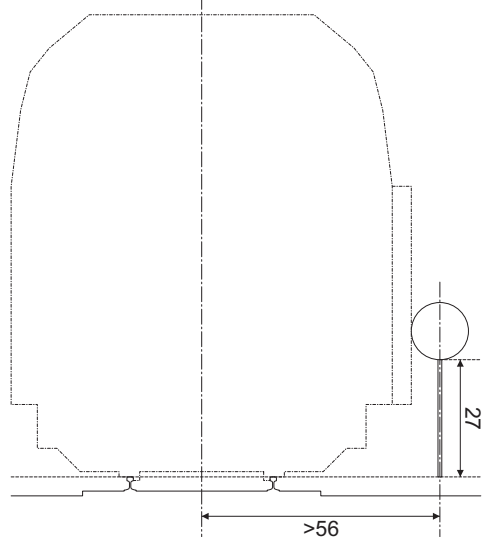

Sygnal D1

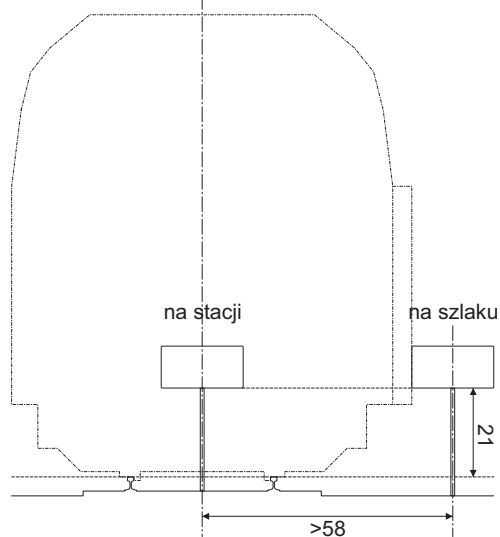

Sygnal D6

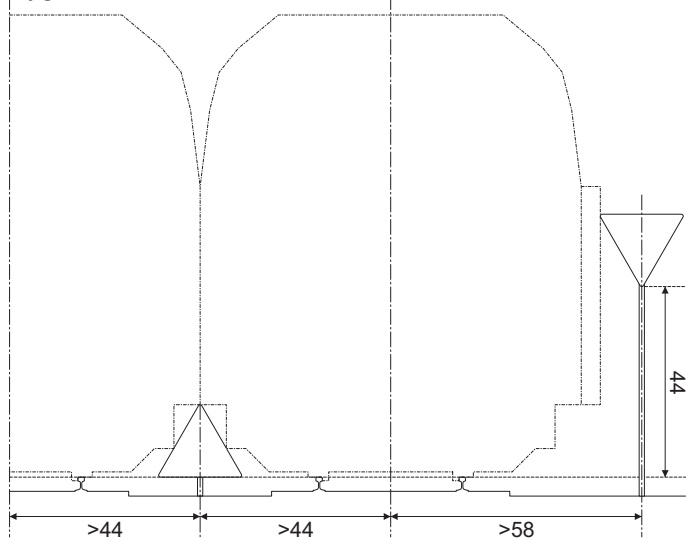

Wskaźnik W1

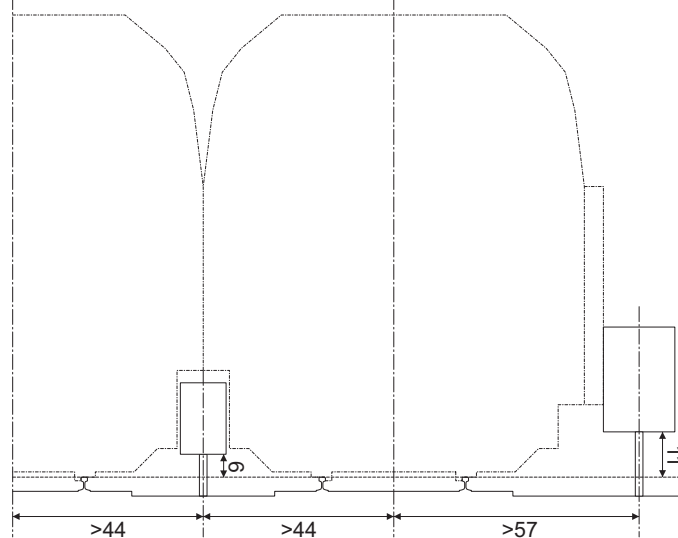

Wskaźnik W4

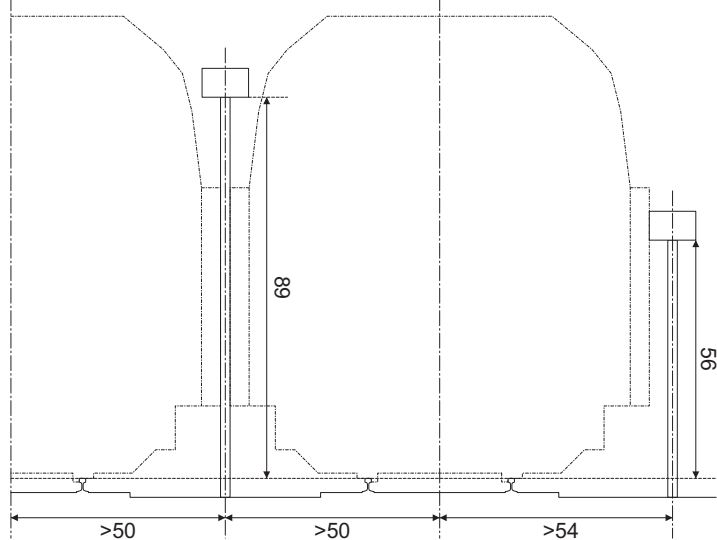

Wskaźnik W5

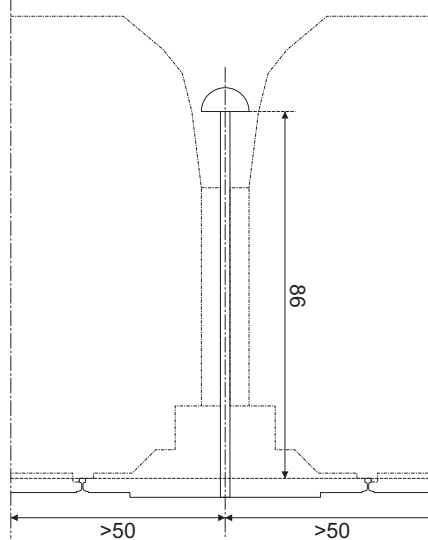

## Wskaźniki kolejowe PKP, 1959-2014, skala 1:45 (0)

Położenie wskaźników względem skrajni

Opracował Paweł Adamowicz (<http://pkprepo.net/>), 2020-2021, niektóre prawa zastrzeżone

Wskaźniki W6, W6a

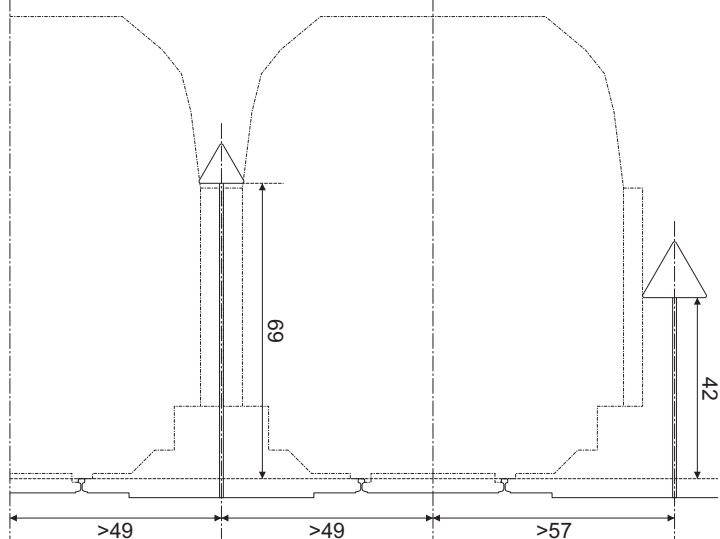

Wskaźnik W7

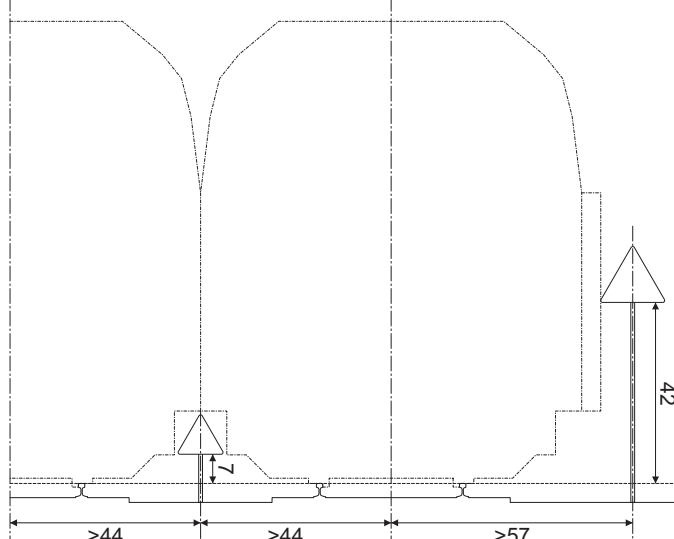

Wskaźnik W8

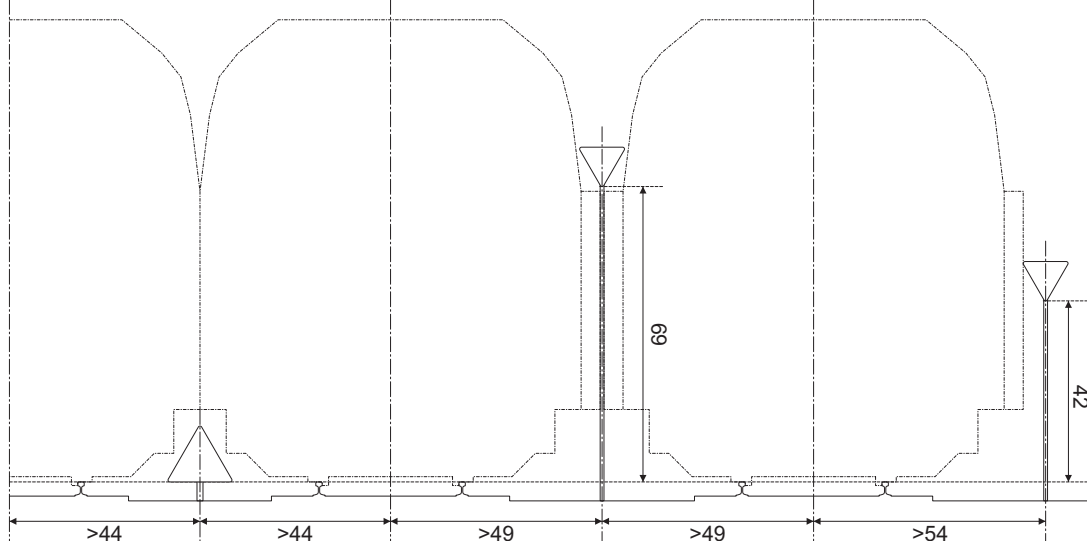

Wskaźniki W9, W14

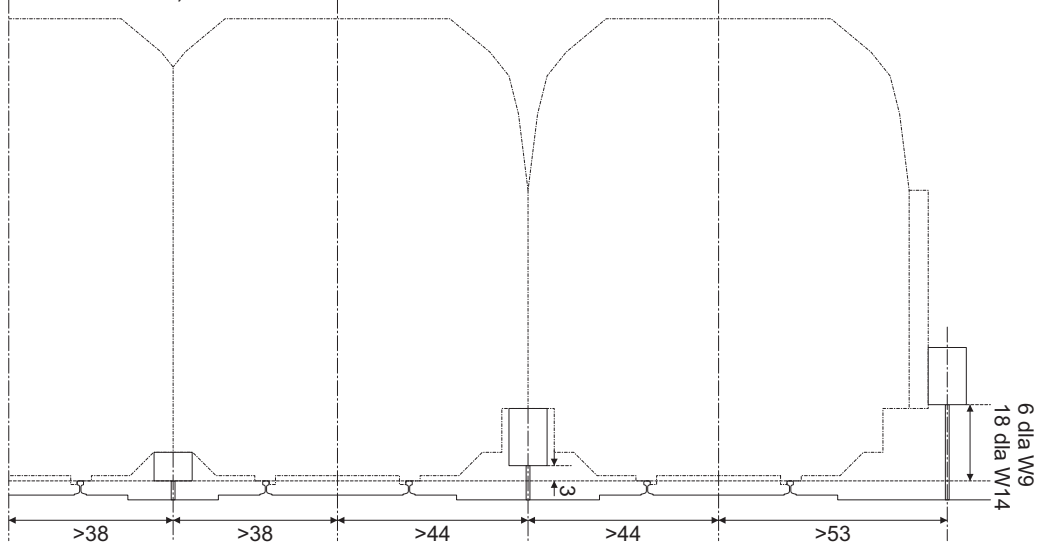

# Wskaźniki kolejowe PKP, 1959-2014, skala 1:45 (0)

Położenie wskaźników względem skrajni

Opracował Paweł Adamowicz (<http://pkprepo.net/>), 2020-2021, niektóre prawa zastrzeżone

Wskaźniki W11a, W11b, W11p

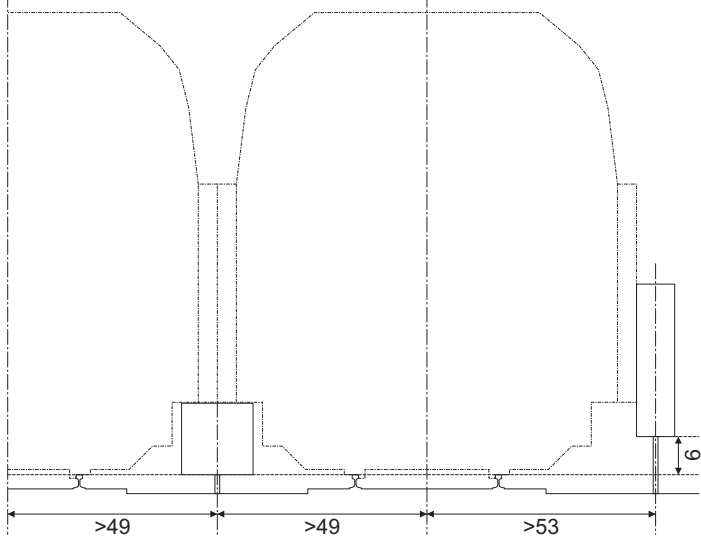

Wskaźnik W12

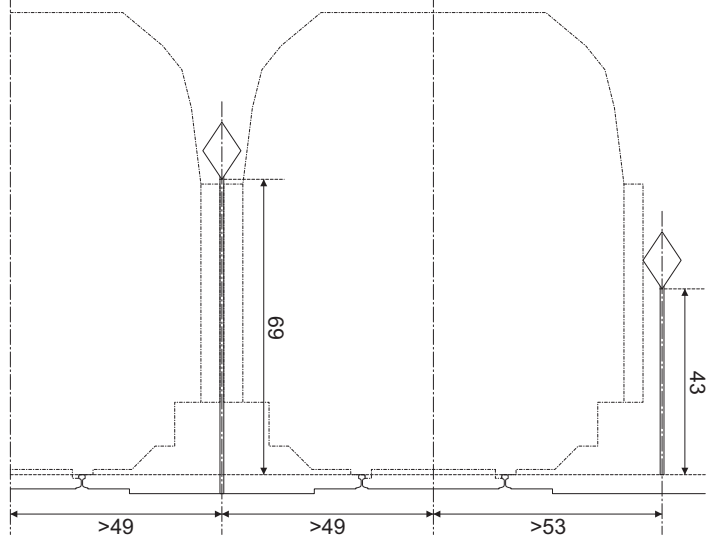

Wskaźnik W13

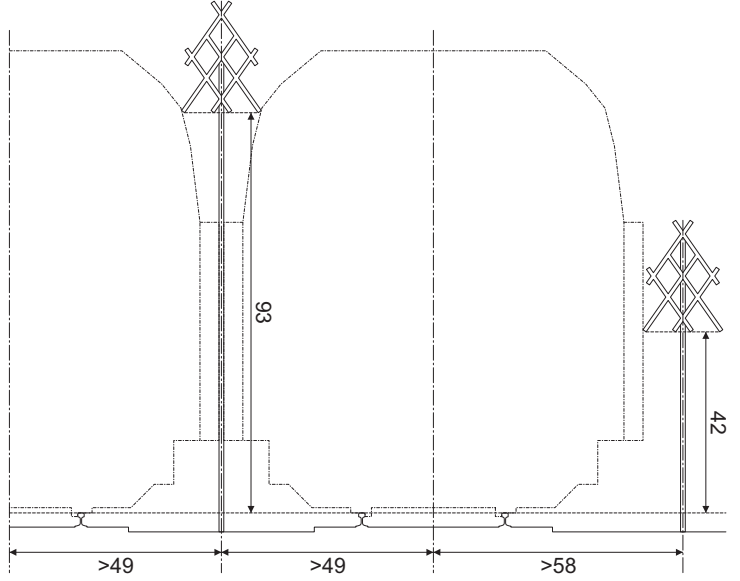
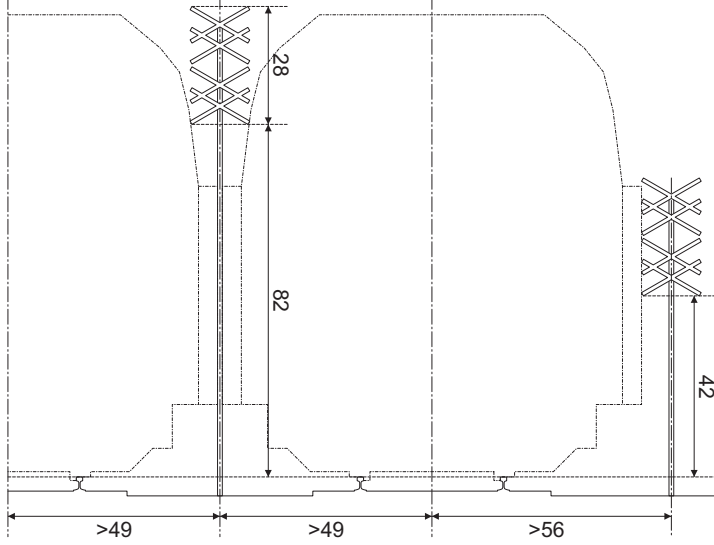

Wskaźnik W15

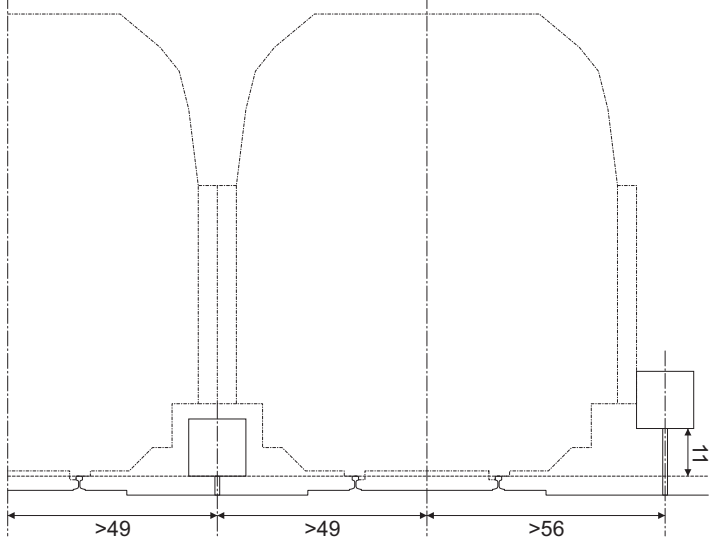

Wskaźniki W16, W29

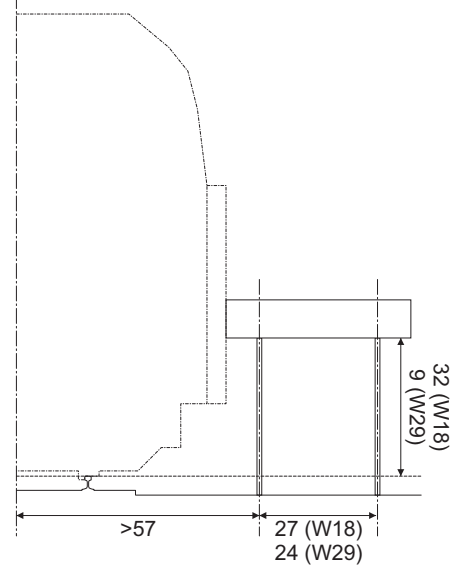

## Wskaźniki kolejowe PKP, 1959-2014, skala 1:45 (0)

Położenie wskaźników względem skrajni

Opracował Paweł Adamowicz (<http://pkprepo.net/>), 2020-2021, niektóre prawa zastrzeżone 

Wskaźnik W17

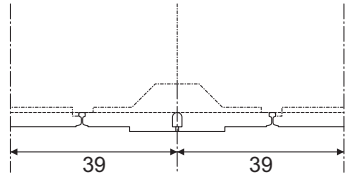

Wskaźnik W23

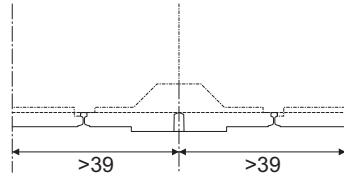

Wskaźnik W18

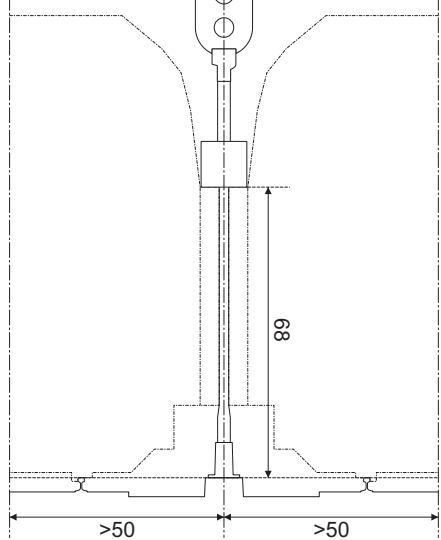

Wskaźniki W19, W20, W21, W24

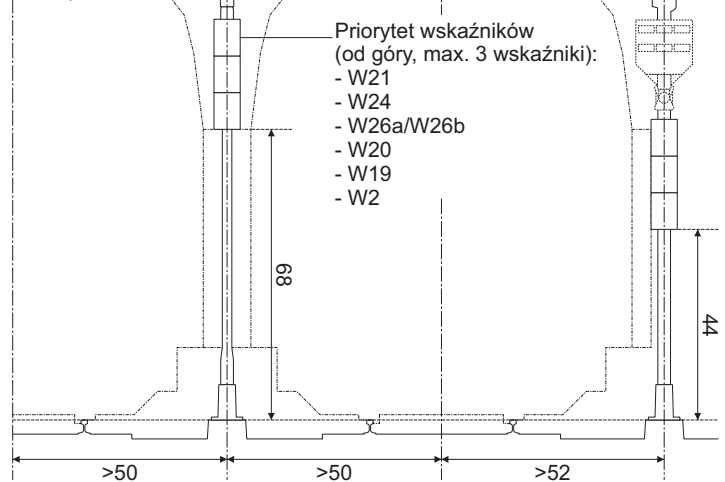

Priorytet wskaźników  
(od góry, max. 3 wskaźniki):

- W21
- W24
- W26a/W26b
- W20
- W19
- W2

Wskaźnik W22

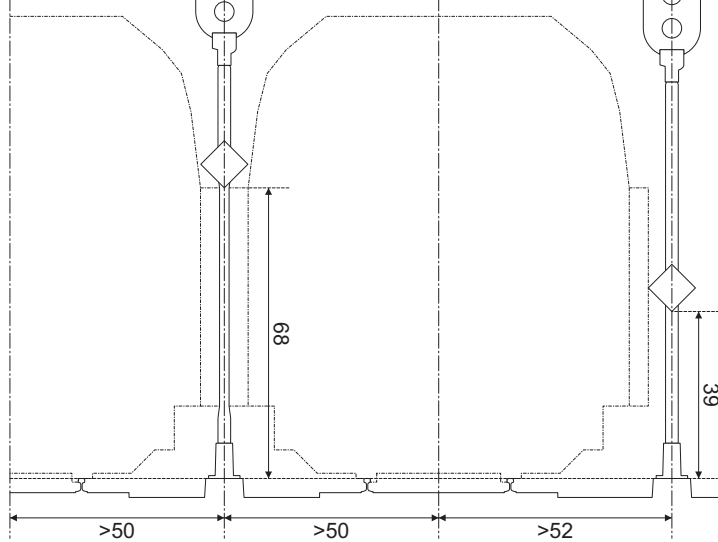

Wskaźnik W27

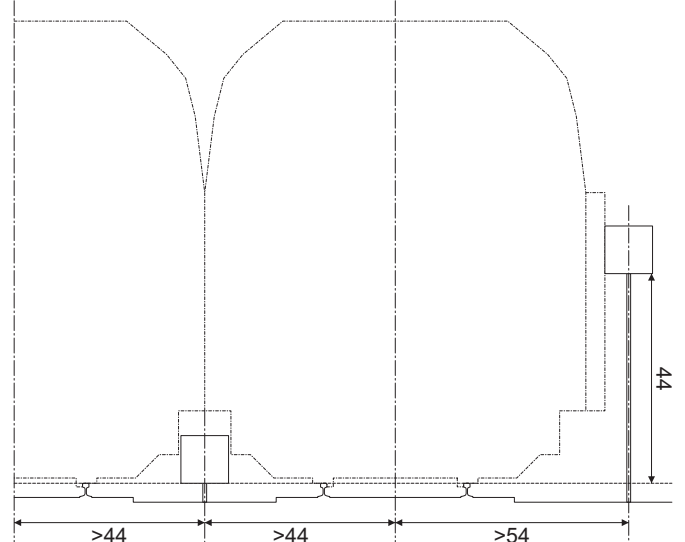

Wskaźnik W28

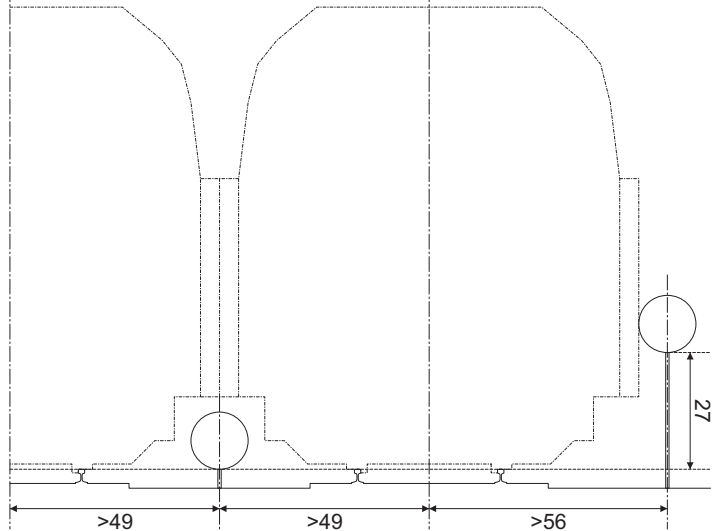

Wskaźnik W31

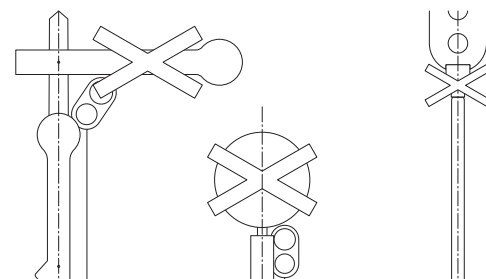

Zdjęte soczewki  
lub przesłona  
opuszczona

# Wskaźniki kolejowe PKP, 1959-2014, skala 1:45 (0)

Położenie wskaźników względem skrajni

Wskaźniki W32, We12, We13

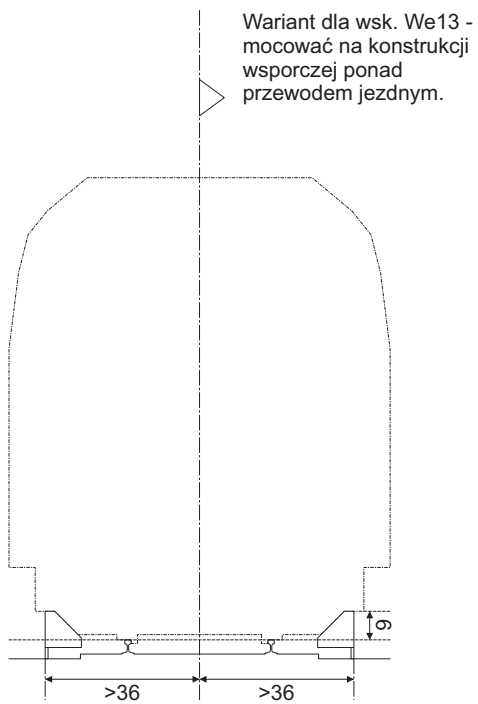

Wskaźniki We1, We2, We3, We4, We8, We9

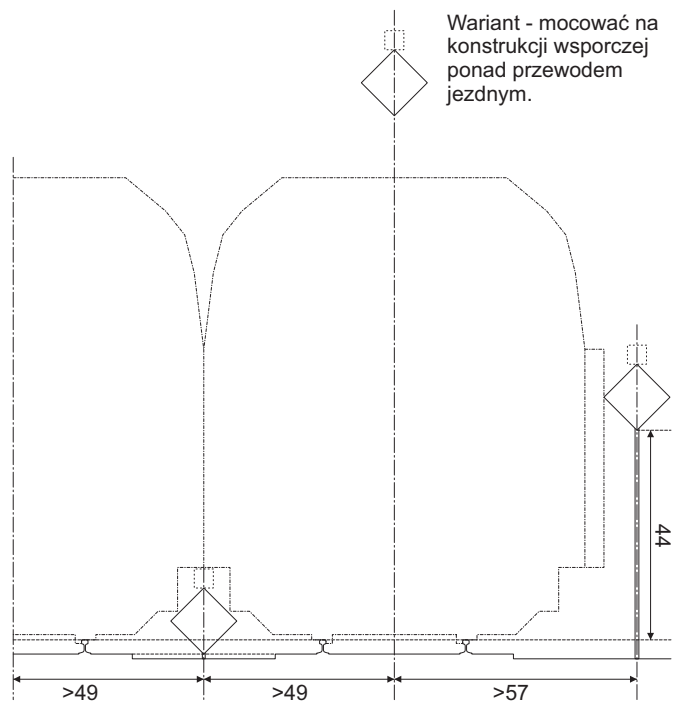

Tablice kolejności sygnalizatorów powtarzających

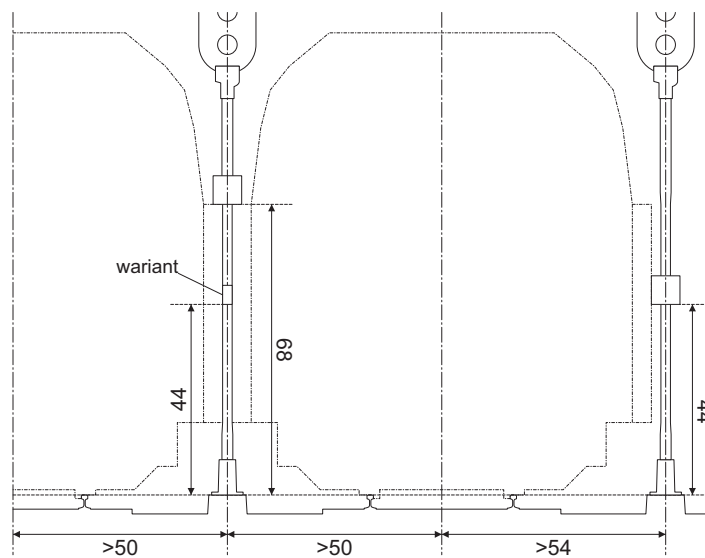

Wskaźniki kolejowe PKP, 1959-2014, skala 1:45 (0)

Położenie wskaźników względem skrajni