

Wskaźniki kolejowe DRG/DR, 1935-1945, skala 1:87 (H0)

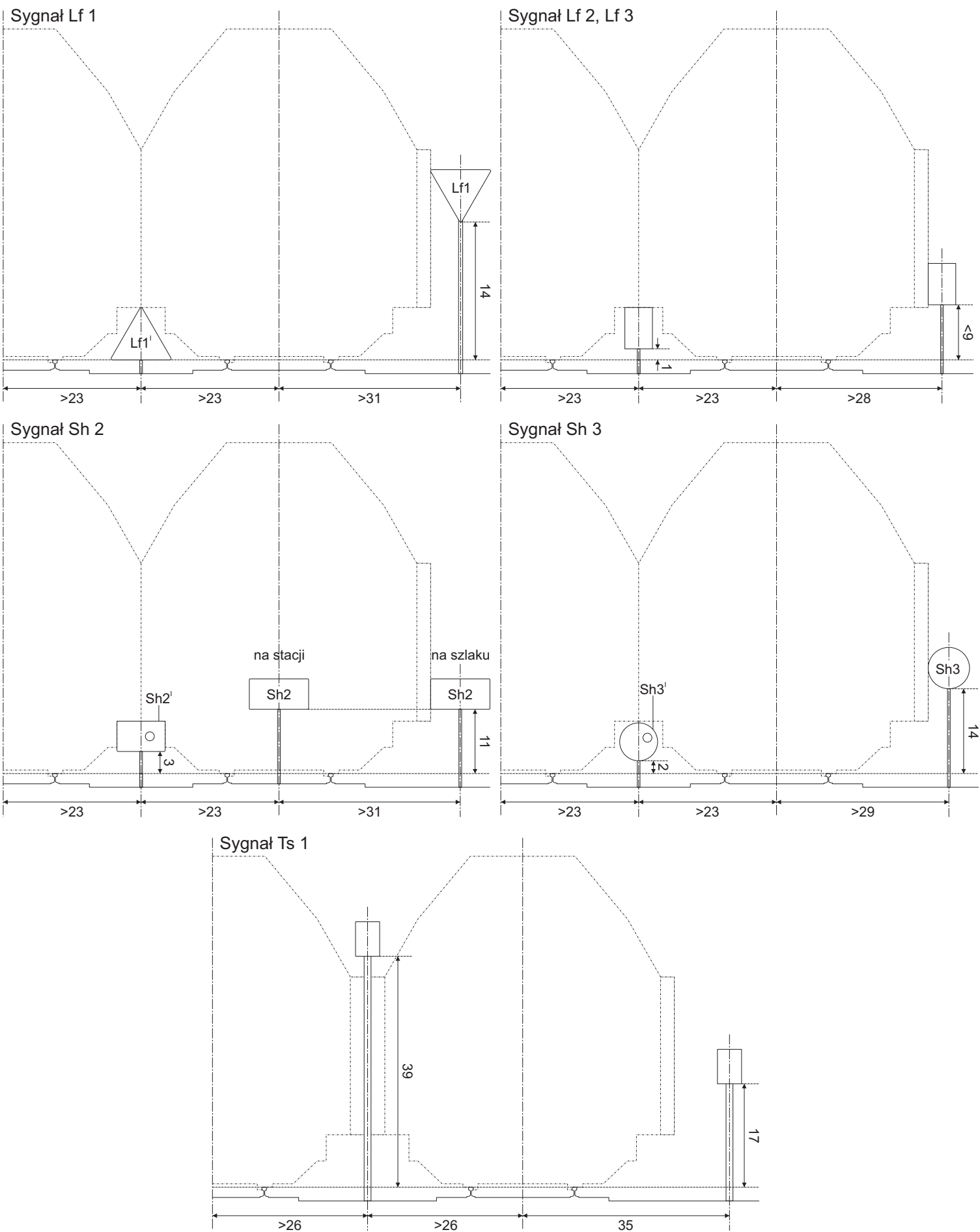

Wskaźniki kolejowe DRG/DR, 1935-1945, skala 1:87 (H0)

Ustawienie wskaźników względem skrajni 1/4

Opracował Paweł Adamowicz (<http://pkprepo.net/>), 2021/2022, niektóre prawa zastrzeżone 

Wskaźnik K 2, K 4

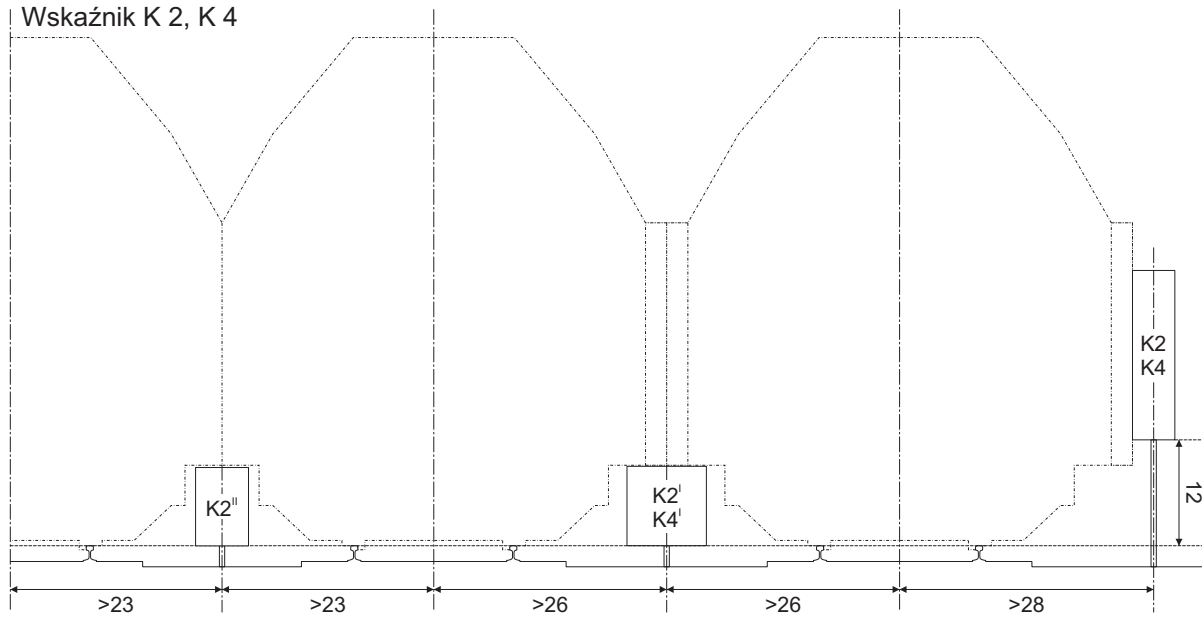

Wskaźnik K 3o, K 3z

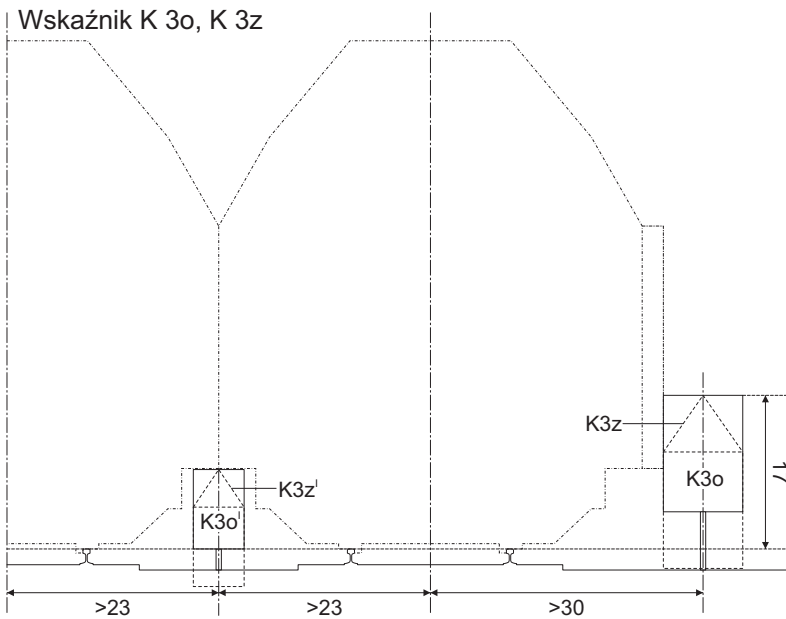

Wskaźnik K 6

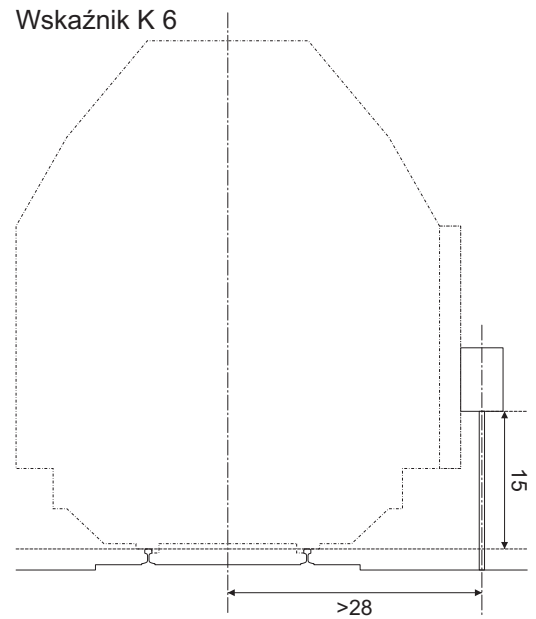

Wskaźnik K 5

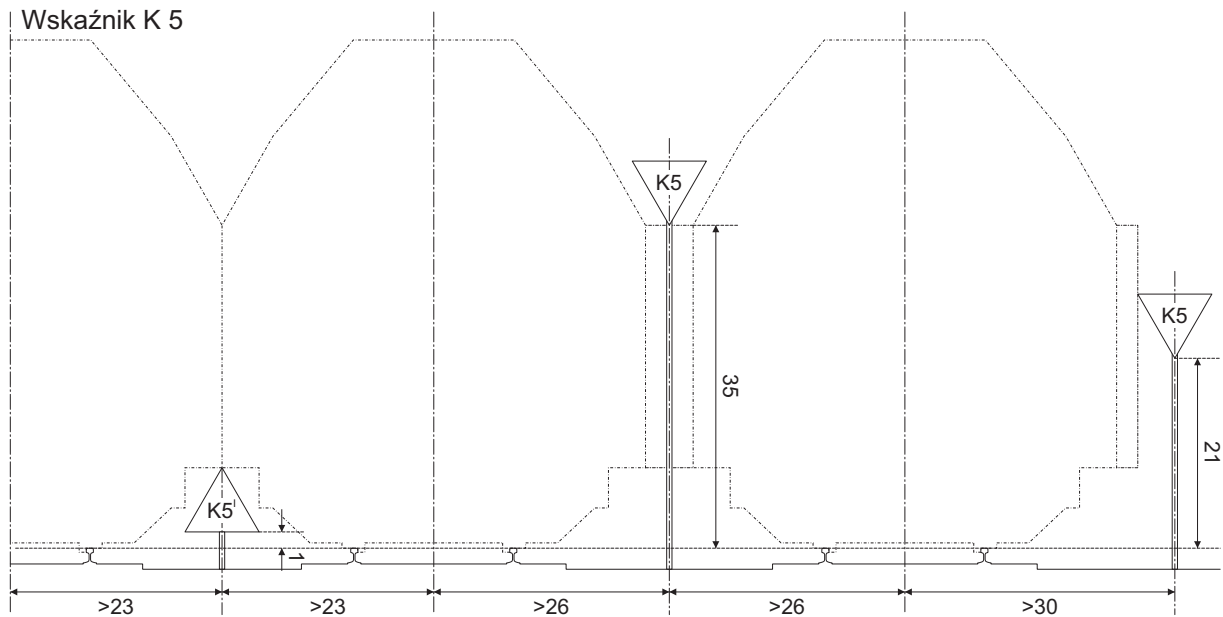

Wskaźniki kolejowe DRG/DR, 1935-1945, skala 1:87 (H0)

Ustawienie wskaźników względem skrajni 2/4

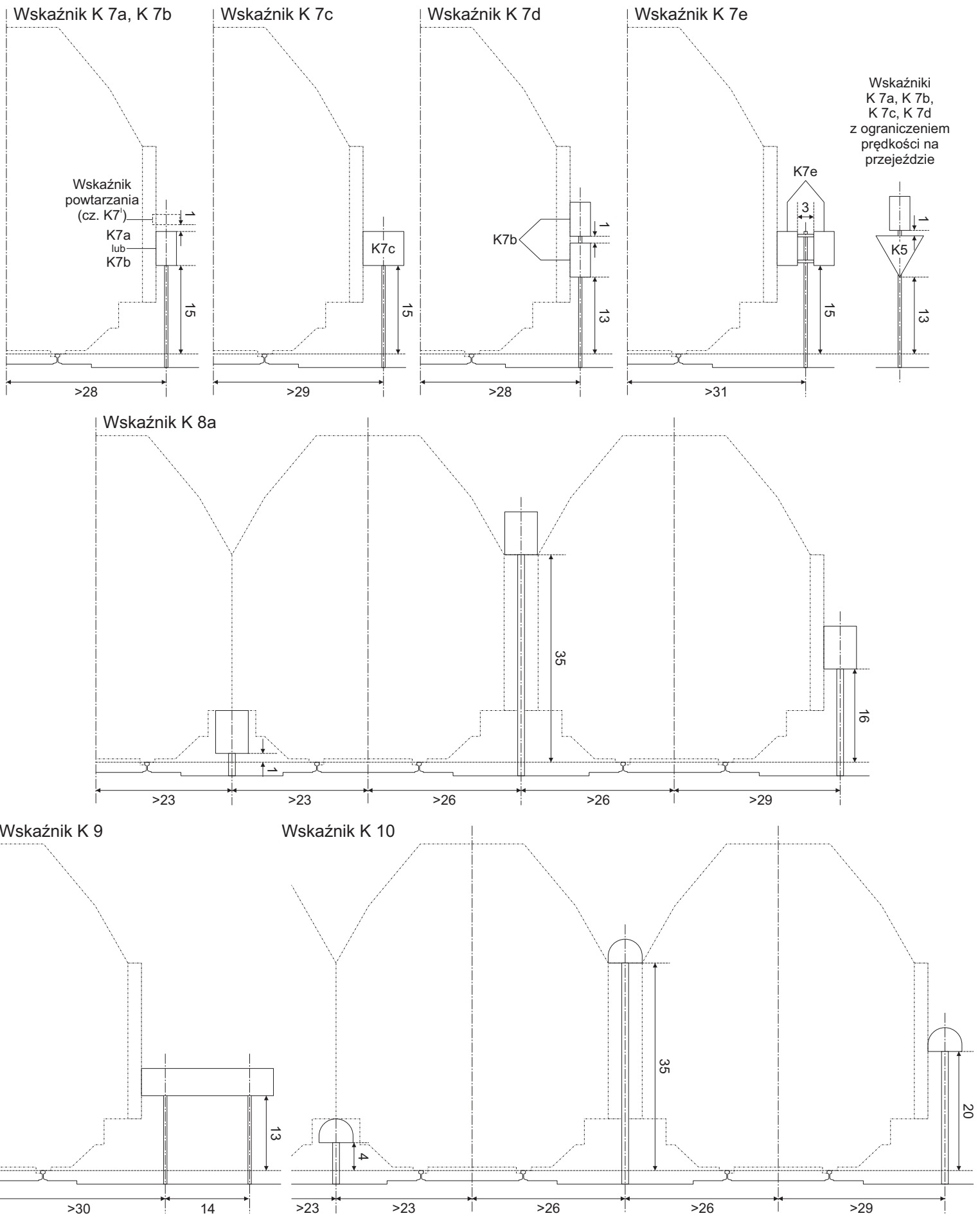

Wskaźniki kolejowe DRG/DR, 1935-1945, skala 1:87 (H0)

Ustawienie wskaźników względem skrajni 3/4

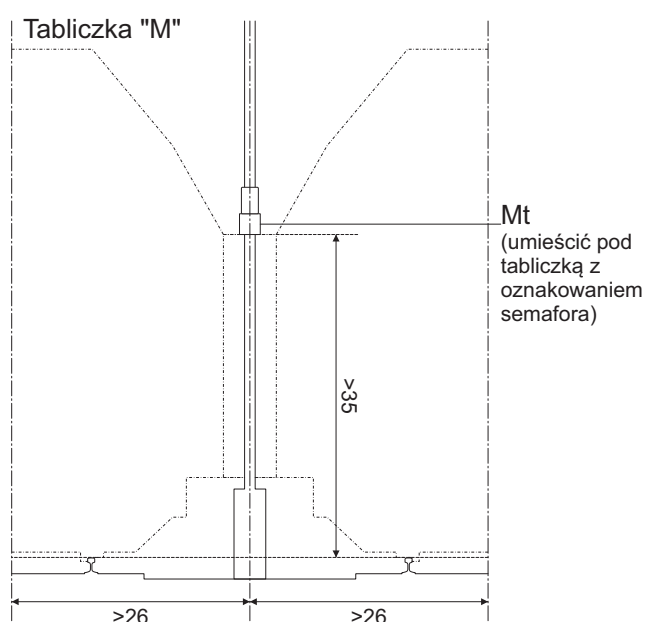
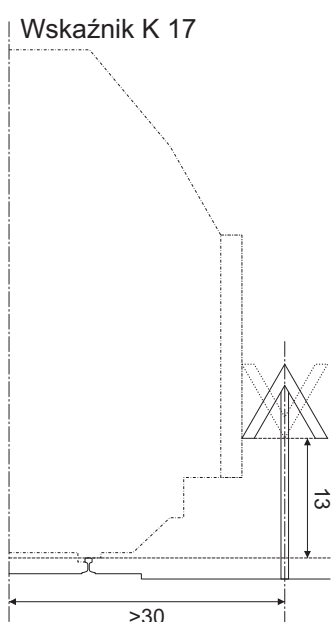
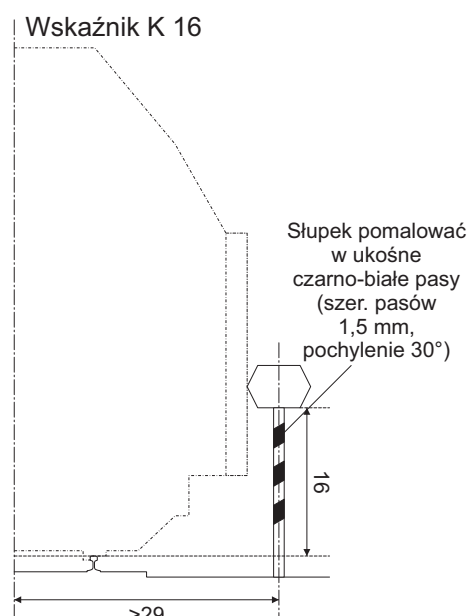
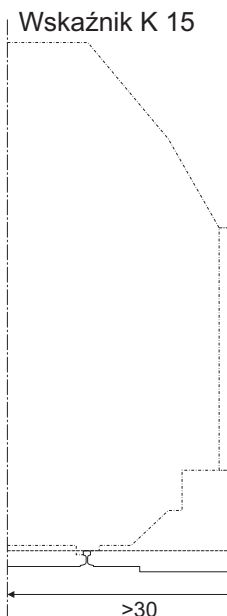
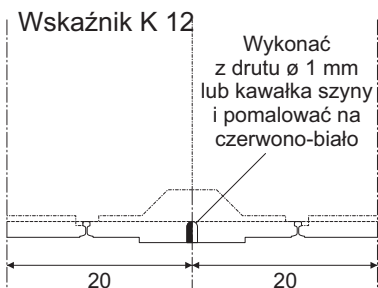

Wskaźniki dla linii zelektryfikowanych EI 1-EI 6, K 8b

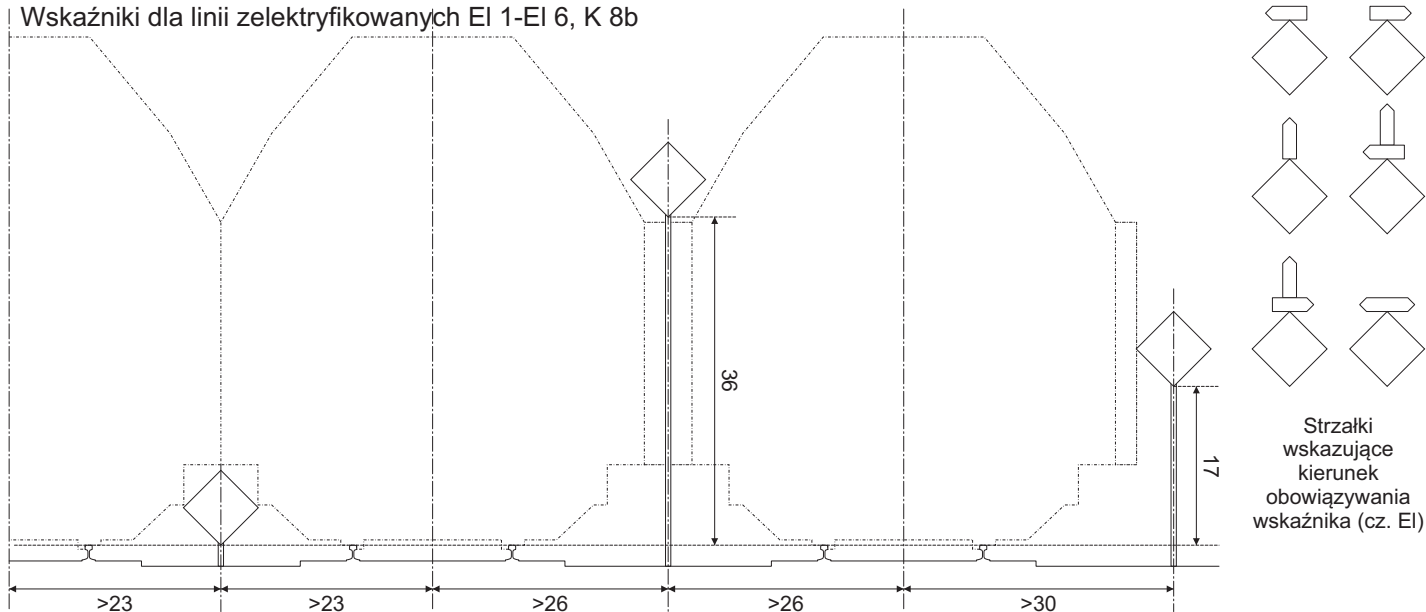

Wskaźniki kolejowe DRG/DR, 1935-1945, skala 1:87 (H0)

Ustawienie wskaźników względem skrajni 4/4