

Wskaźniki kolejowe DRG/DR, 1935-1945, skala 1:45 (0)

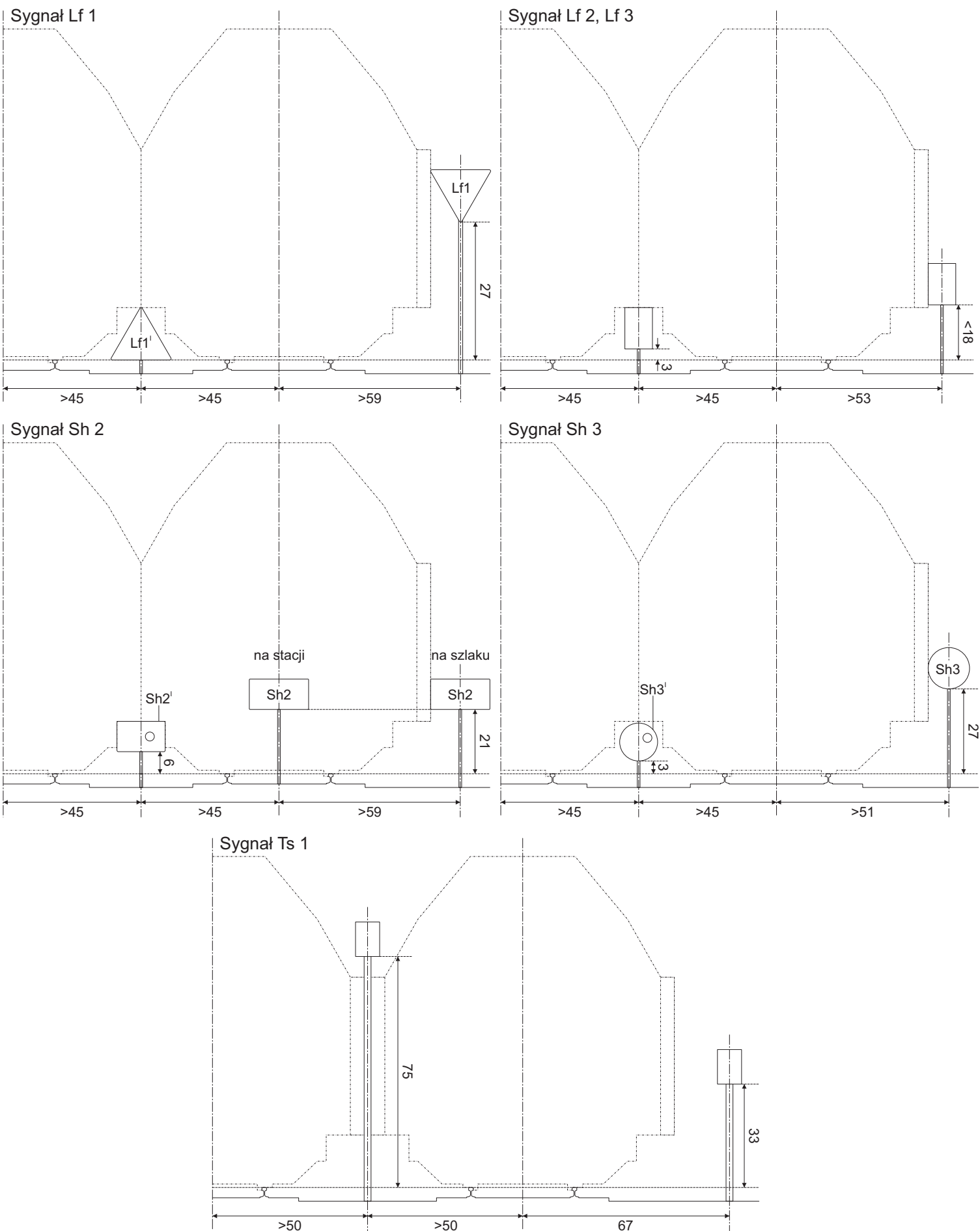

## Wskaźniki kolejowe DRG/DR, 1935-1945, skala 1:45 (0)

Ustawienie wskaźników względem skrajni 1/4

Wskaźnik K 2, K 4

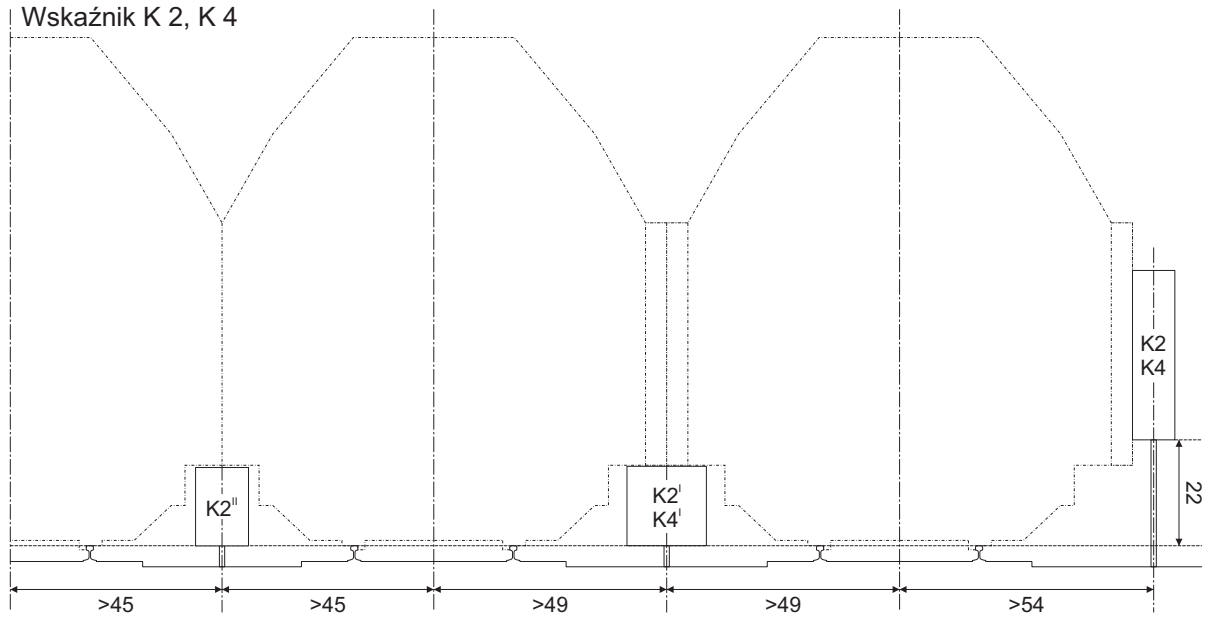

Wskaźnik K 3o, K 3z

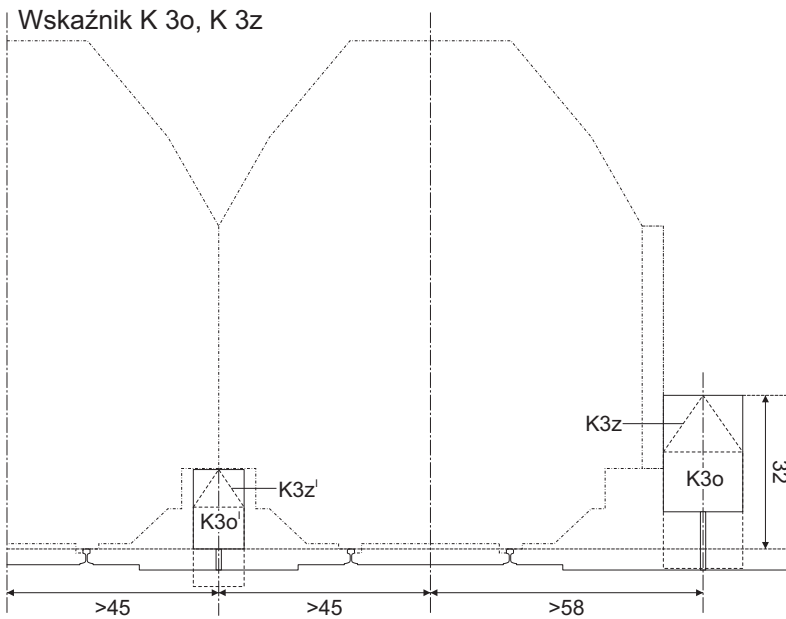

Wskaźnik K 6

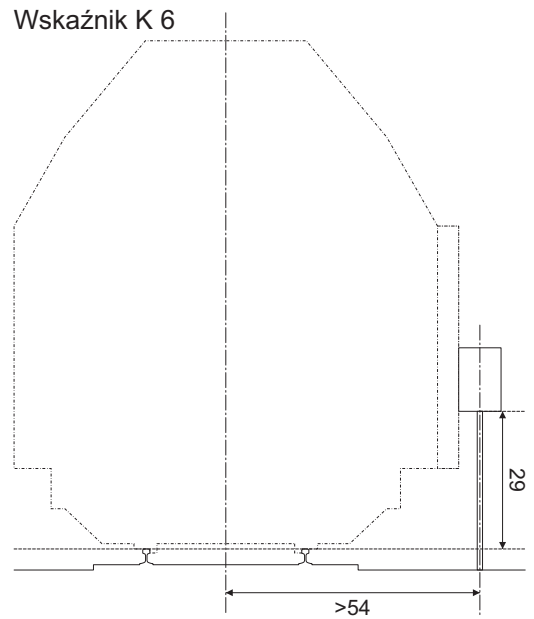

Wskaźnik K 5

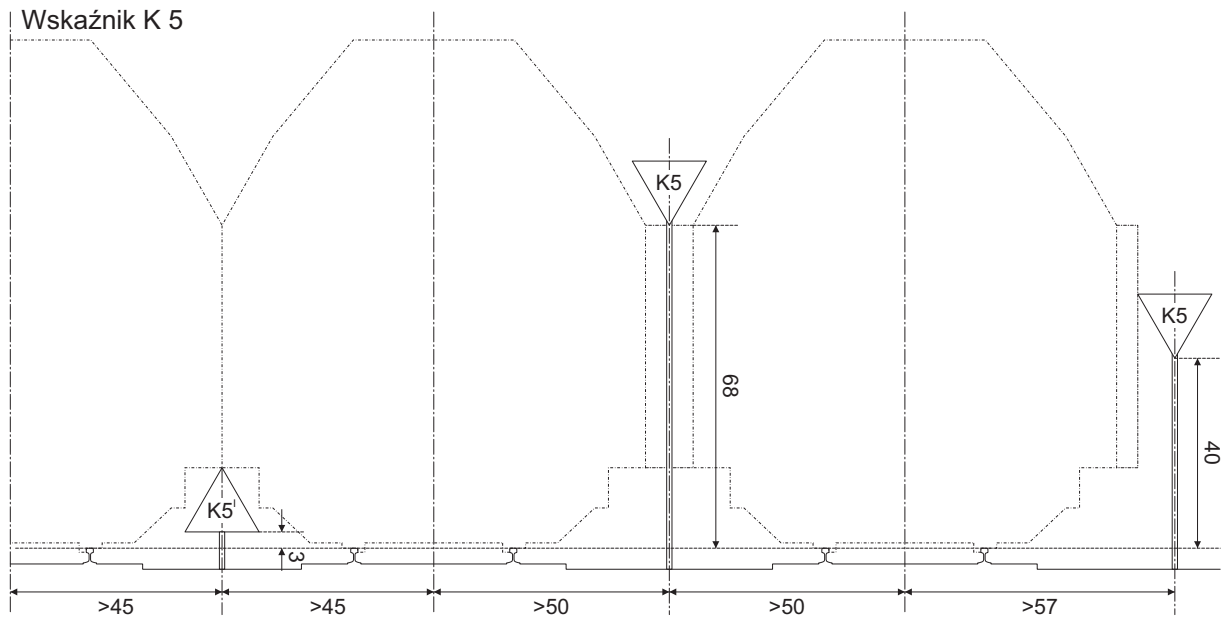

## Wskaźniki kolejowe DRG/DR, 1935-1945, skala 1:45 (0)

Ustawienie wskaźników względem skrajni 2/4

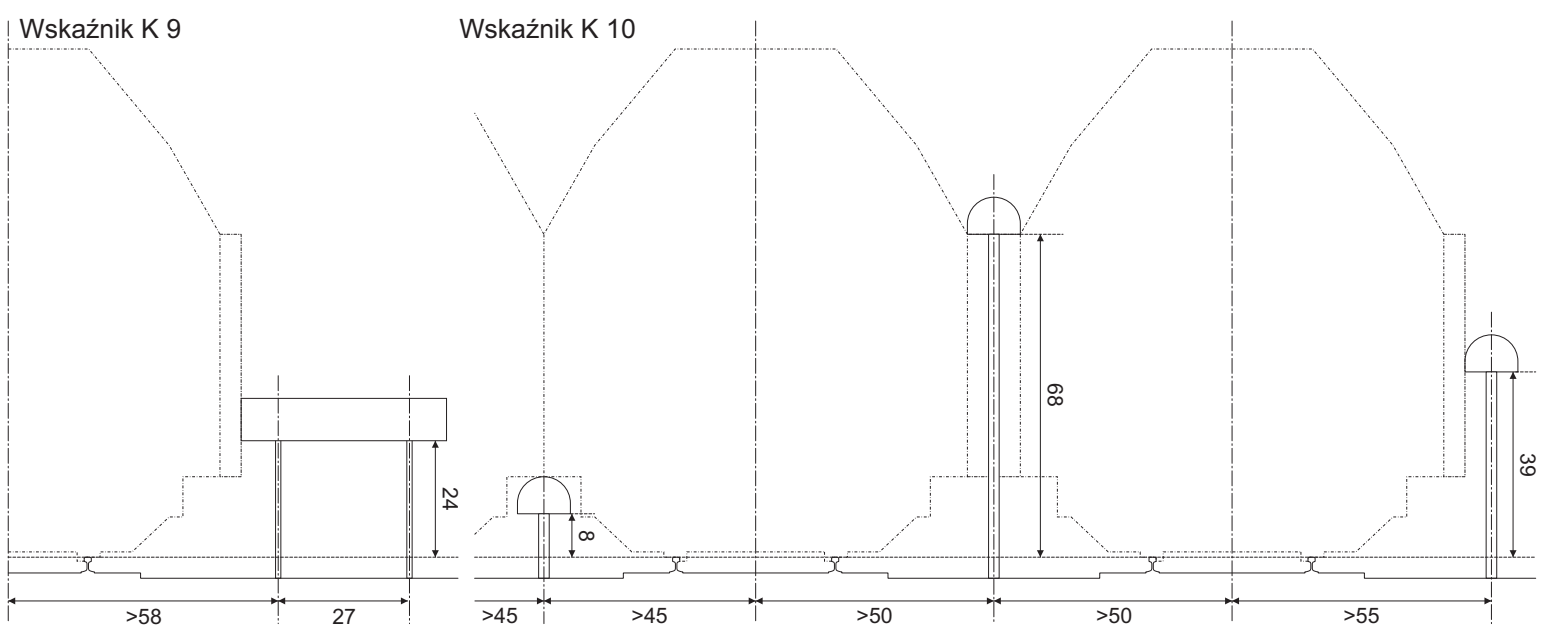
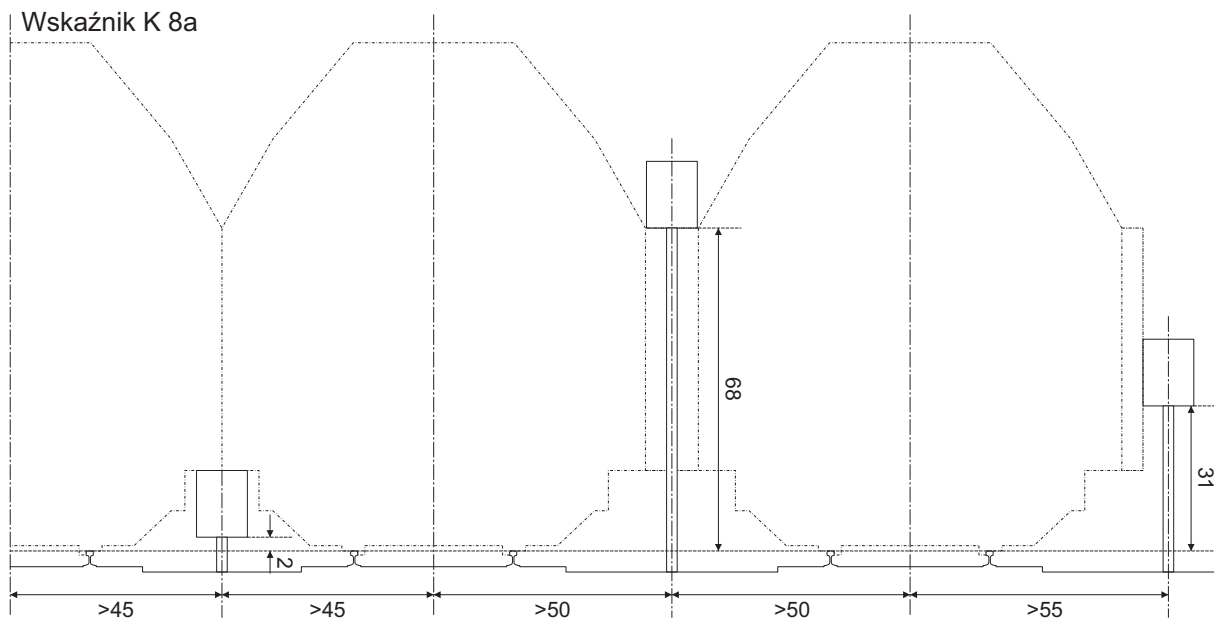
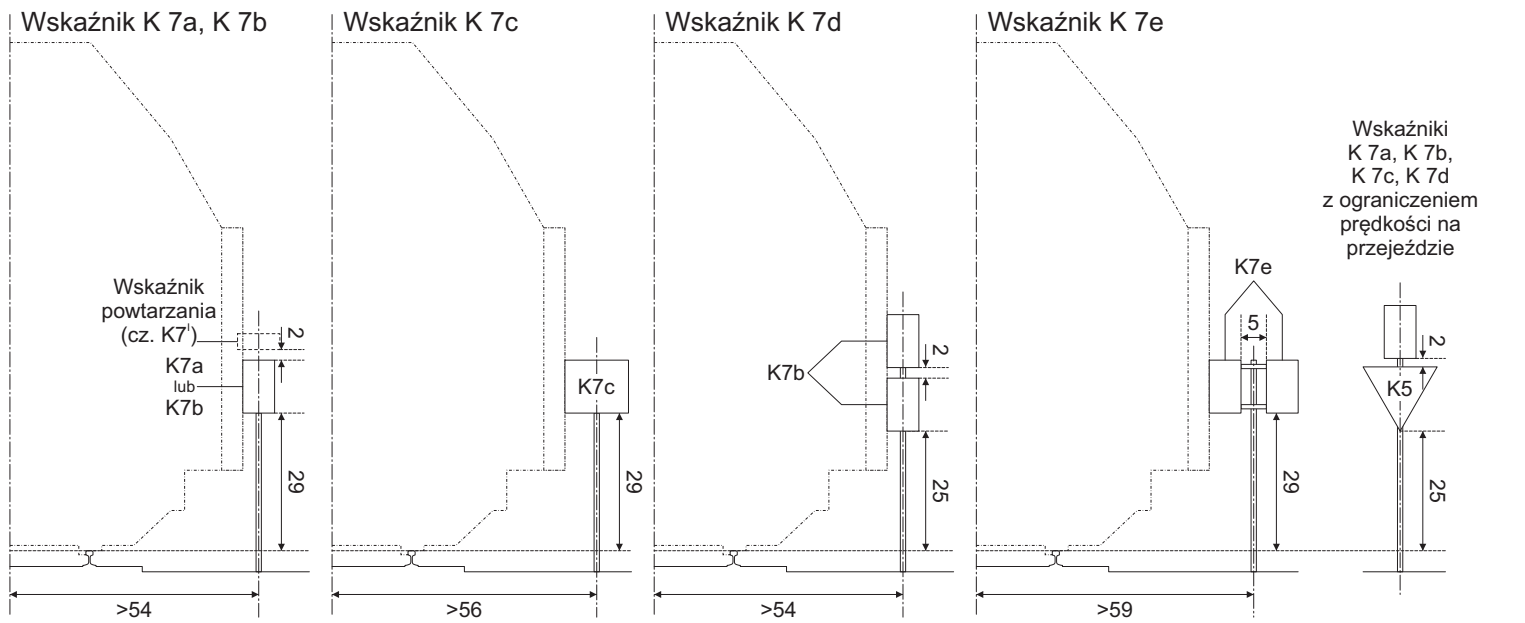

# Wskaźniki kolejowe DRG/DR, 1935-1945, skala 1:45 (0)

Ustawienie wskaźników względem skrajni 3/4

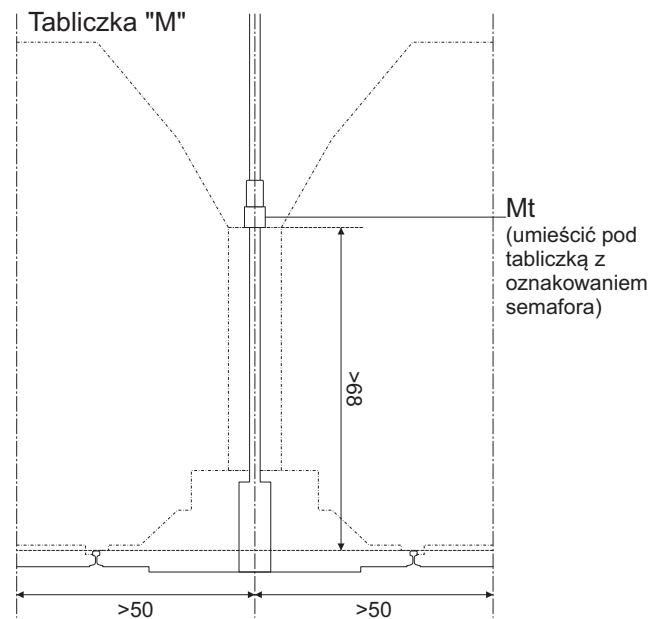
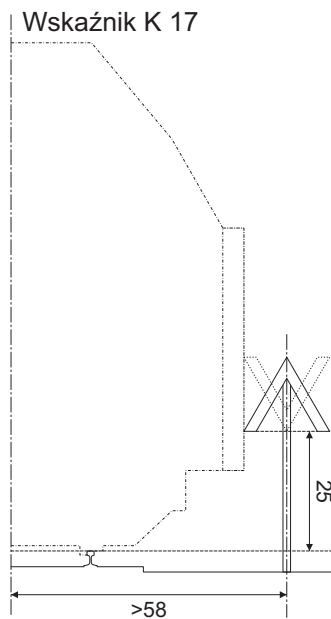
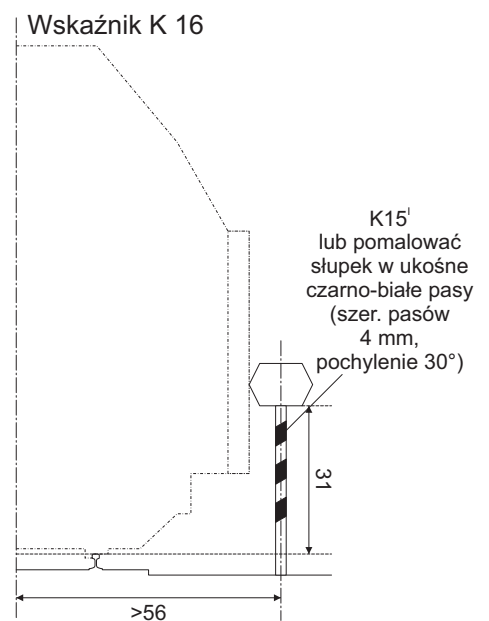
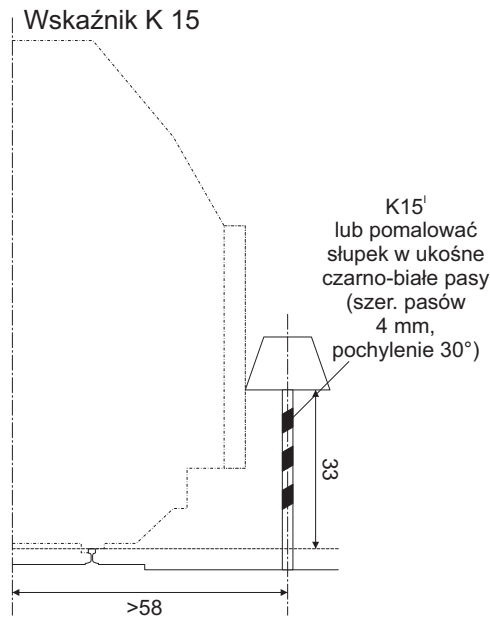
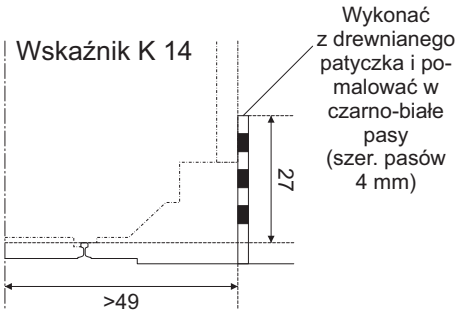
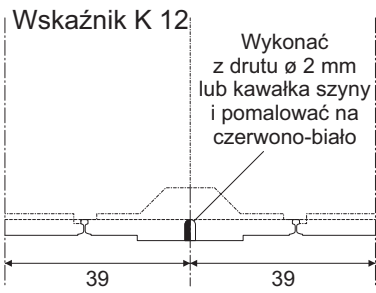

Wskaźniki dla linii zelektryfikowanych EI 1-EI 6, K 8b

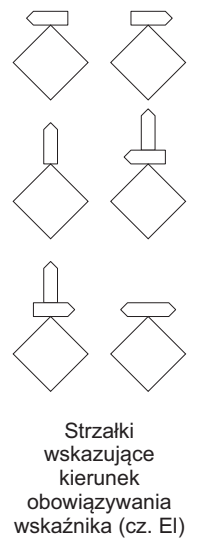
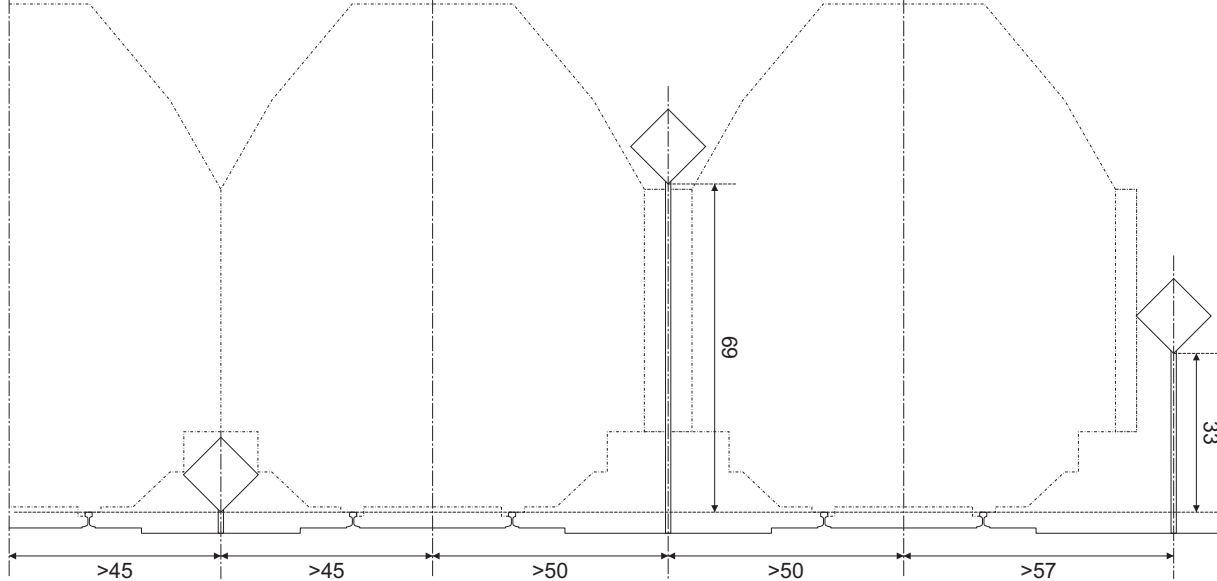

# Wskaźniki kolejowe DRG/DR, 1935-1945, skala 1:45 (0)

Ustawienie wskaźników względem skrajni 4/4