

Wskaźniki kolejowe DRG/DR, 1935-1945, skala 1:25 1cm

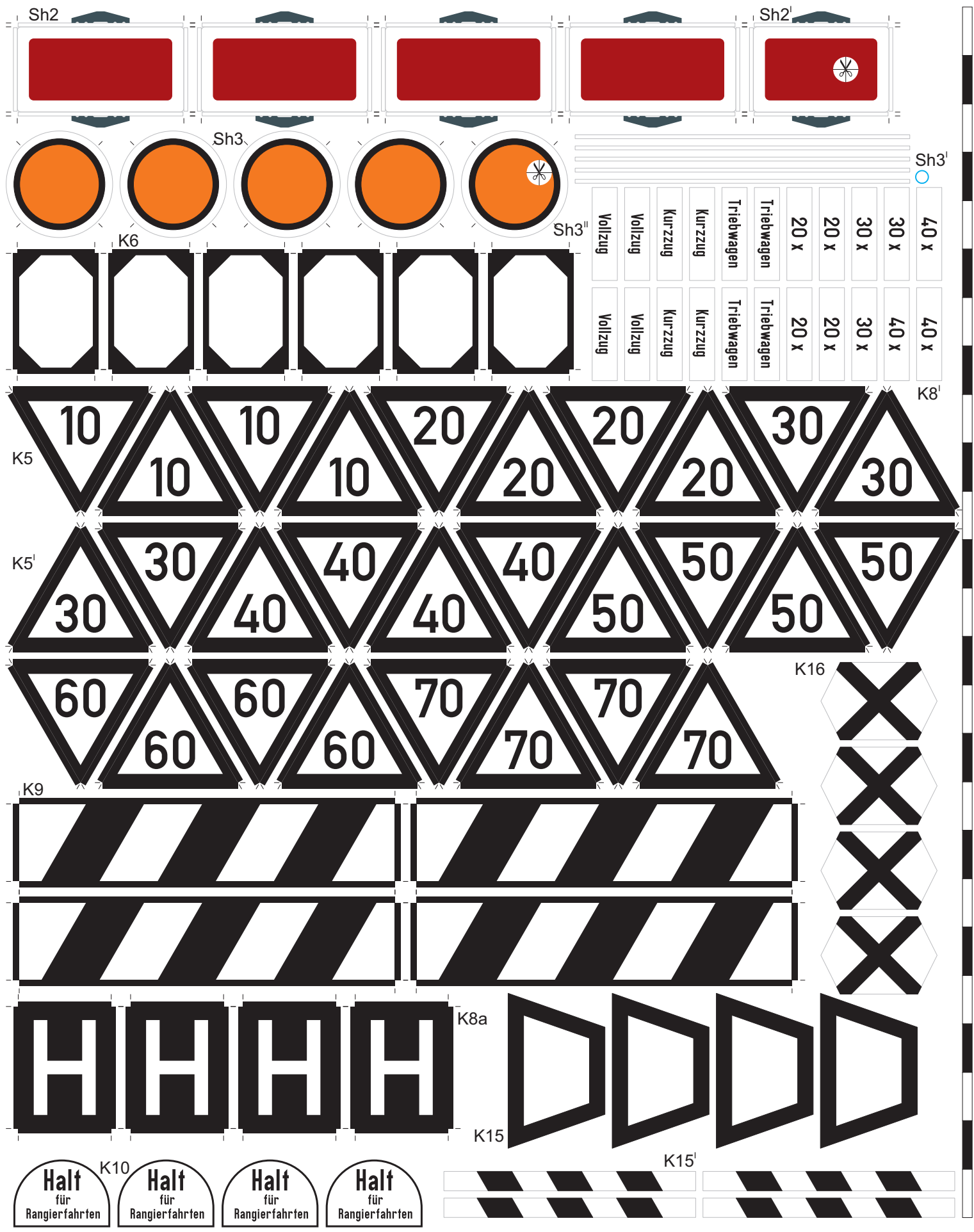

Wskaźniki kolejowe DRG/DR, 1935-1945, skala 1:25

1cm

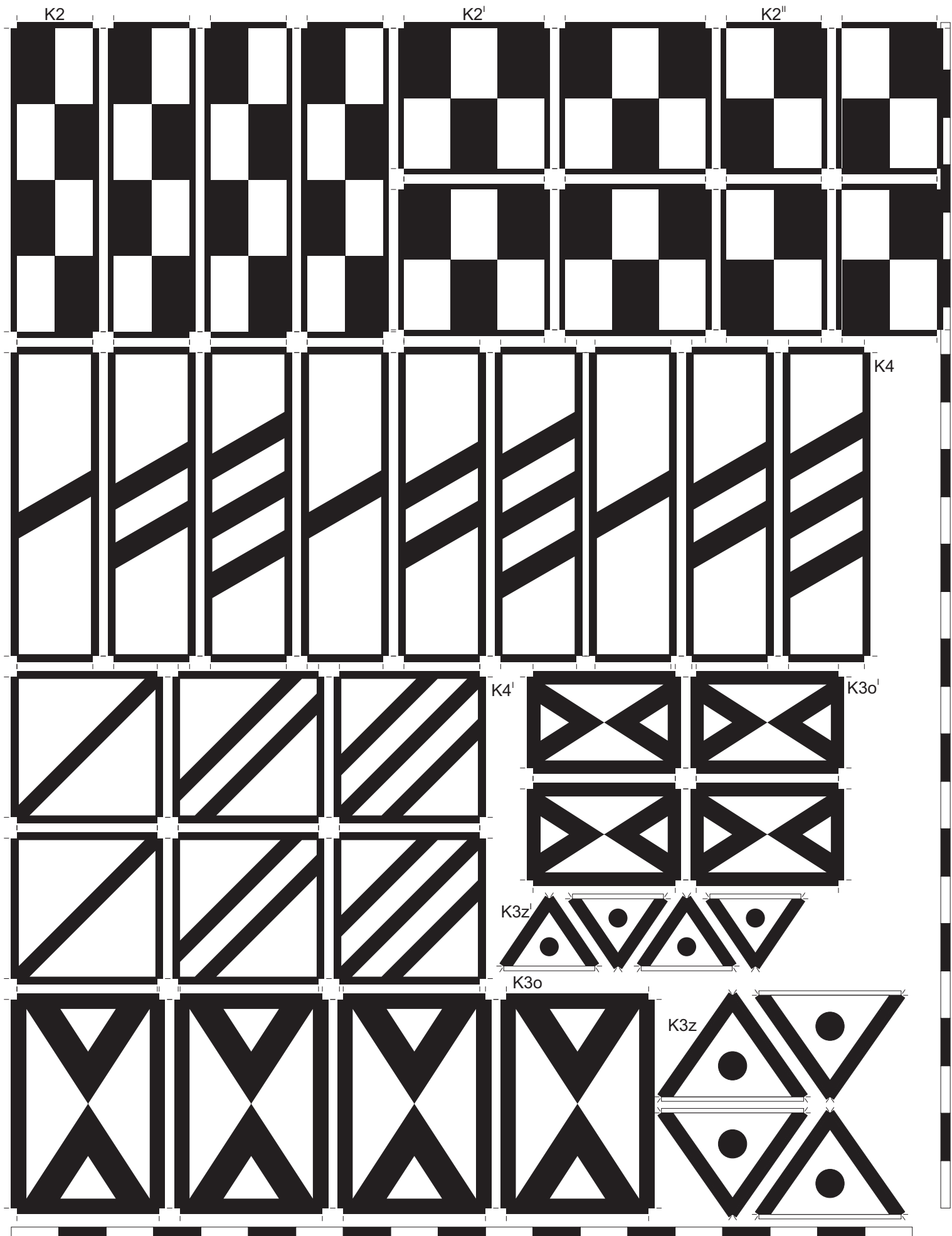

Wskaźniki kolejowe DRG/DR, 1935-1945, skala 1:25

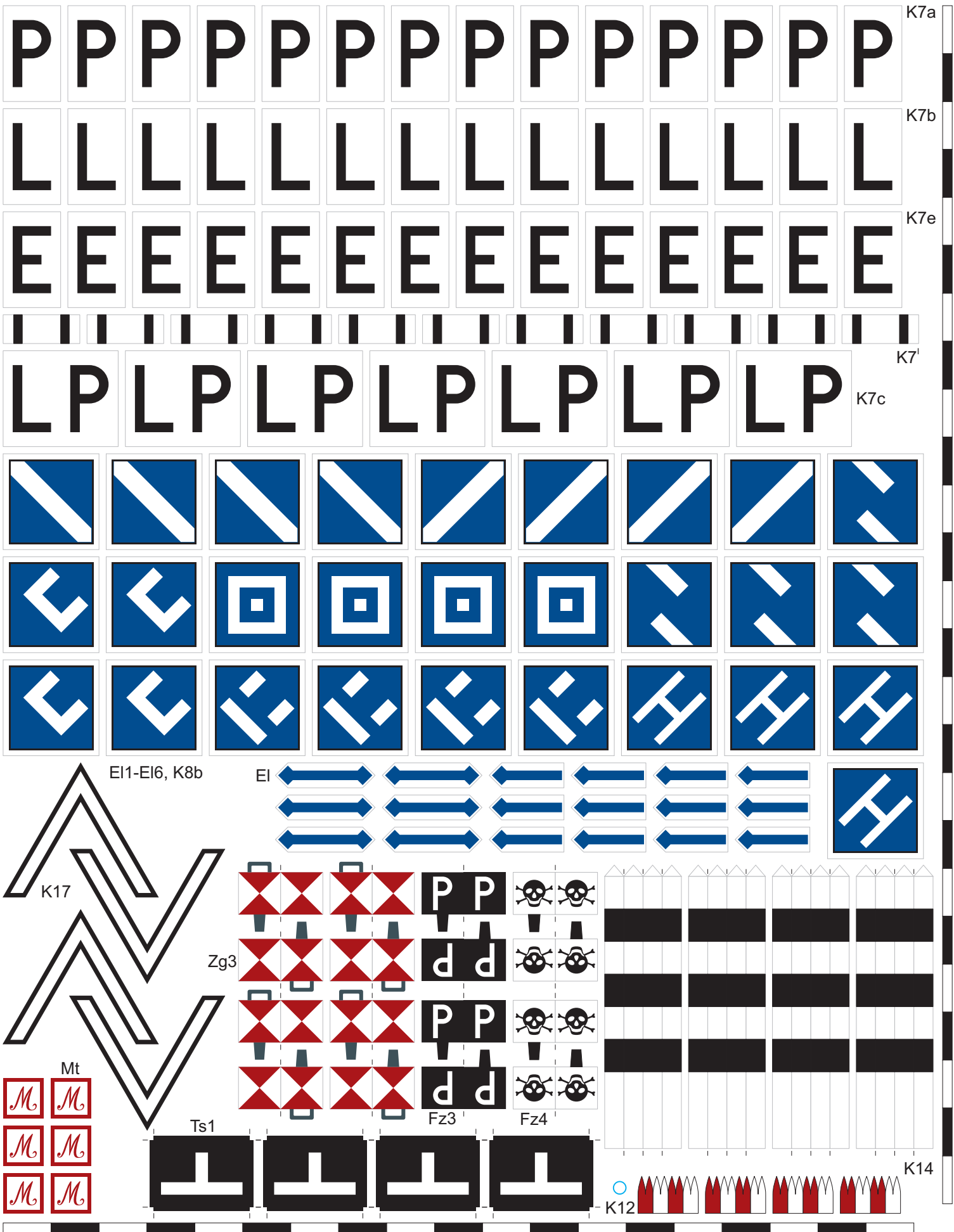

Wskazniki kolejowe DRG/DR, 1935-1945, skala 1:25

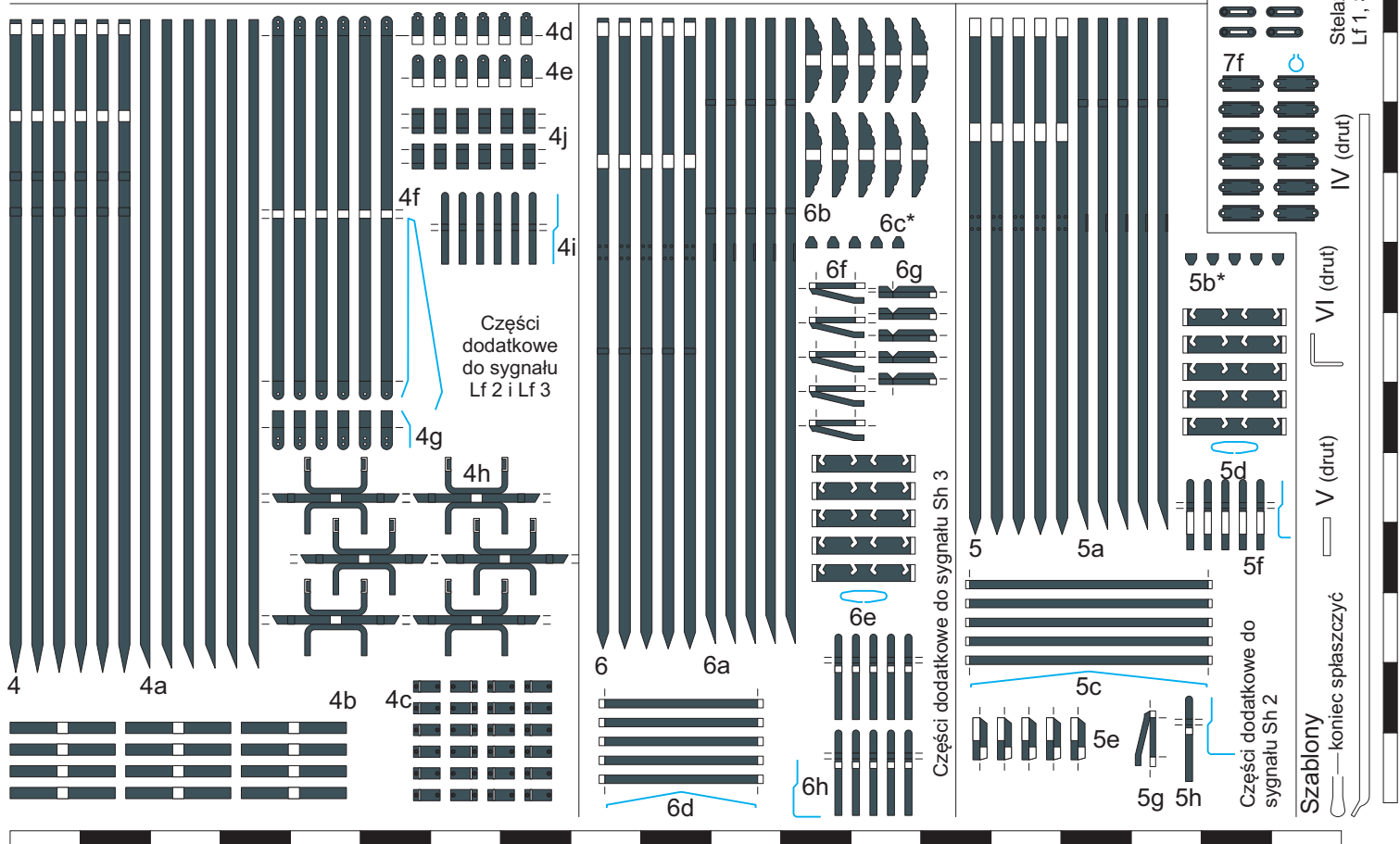
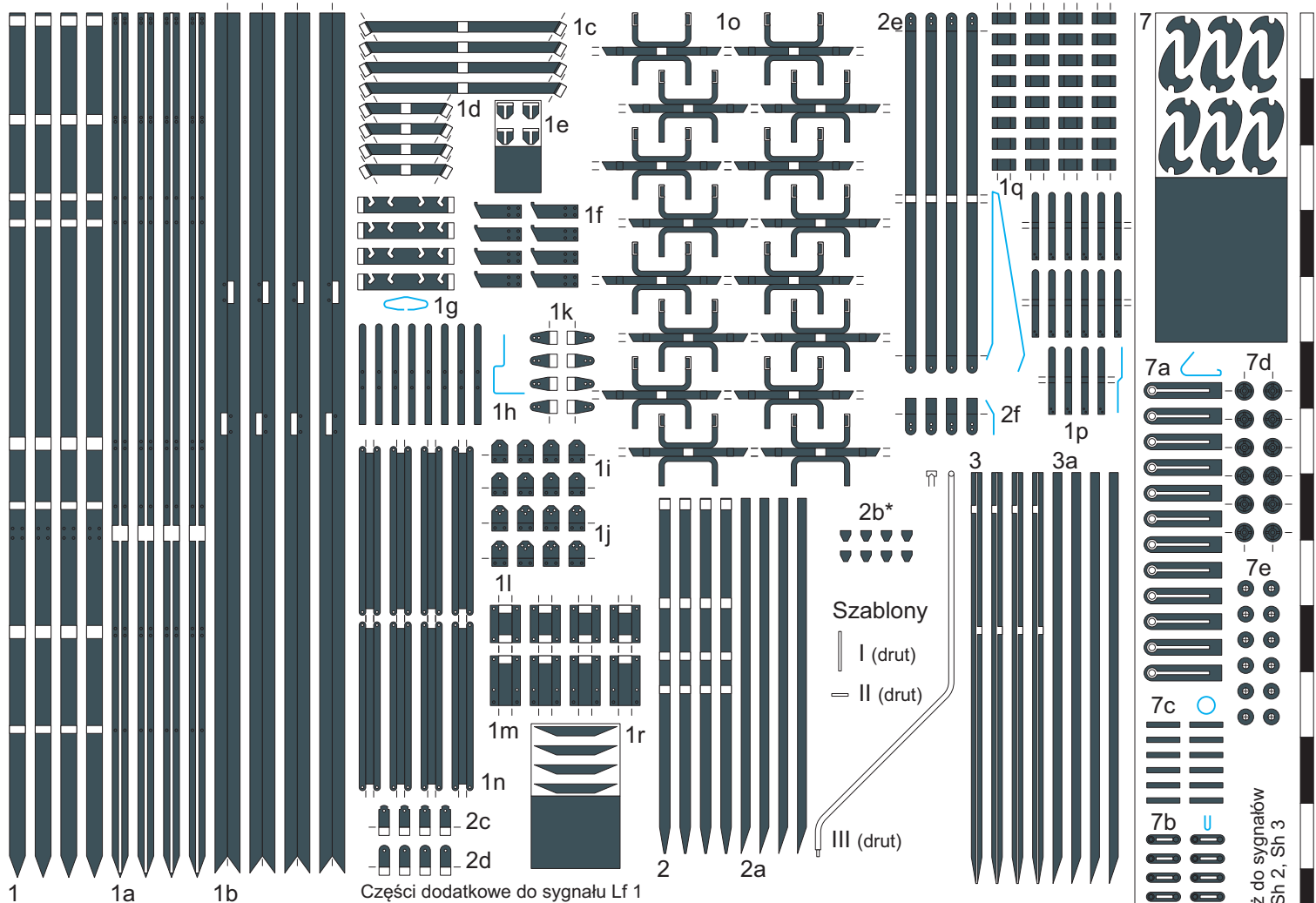

Wskaźniki kolejowe DRG/DR, 1935-1945, skala 1:25

Części dodatkowe

Opracował Paweł Adamowicz (<http://pkprepo.net/>), 2021/2022, niektóre prawa zastrzeżone

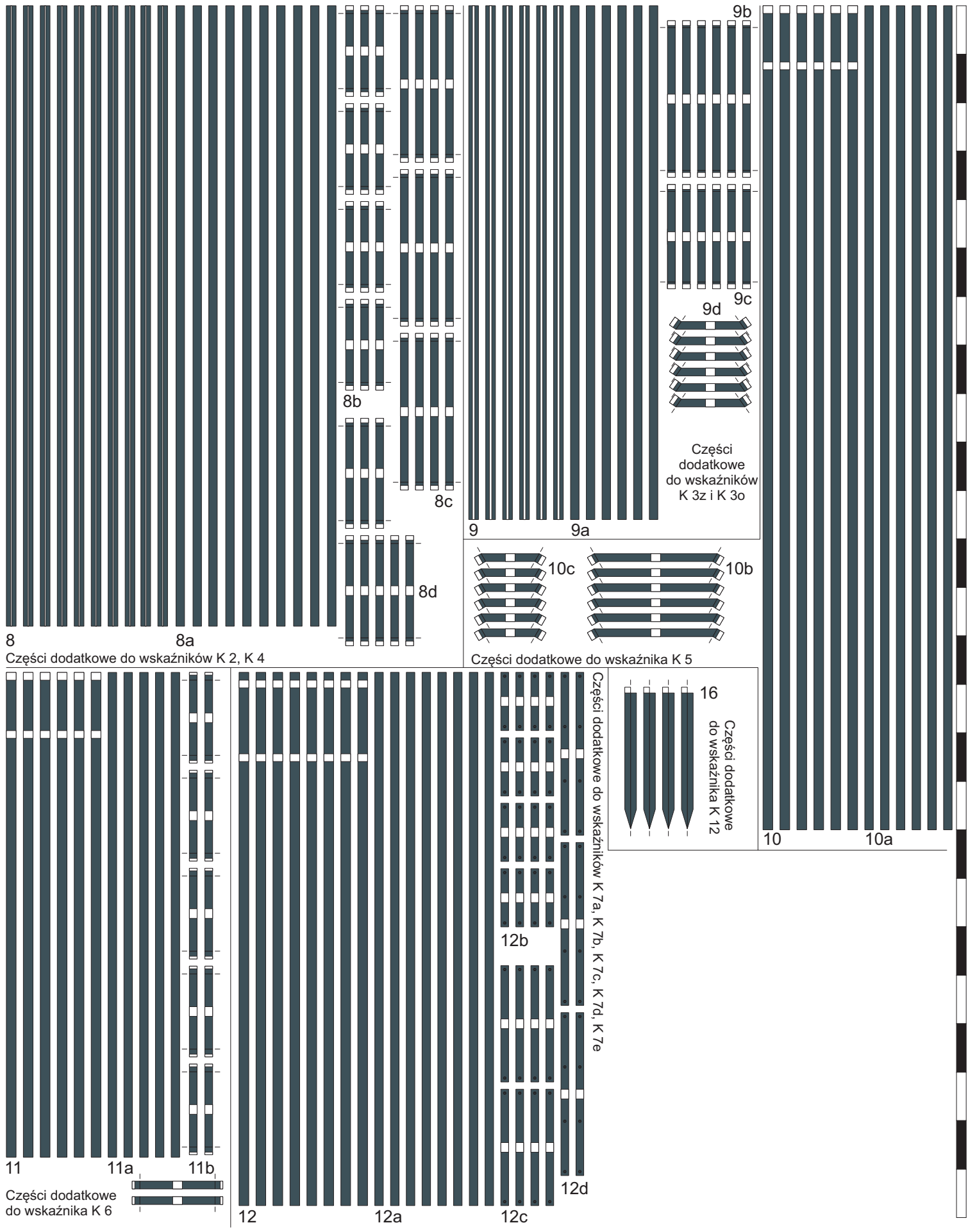

Wskaźniki kolejowe DRG/DR, 1935-1945, skala 1:25

Części dodatkowe

Opracował Paweł Adamowicz (<http://pkprepo.net/>), 2021/2022, niektóre prawa zastrzeżone

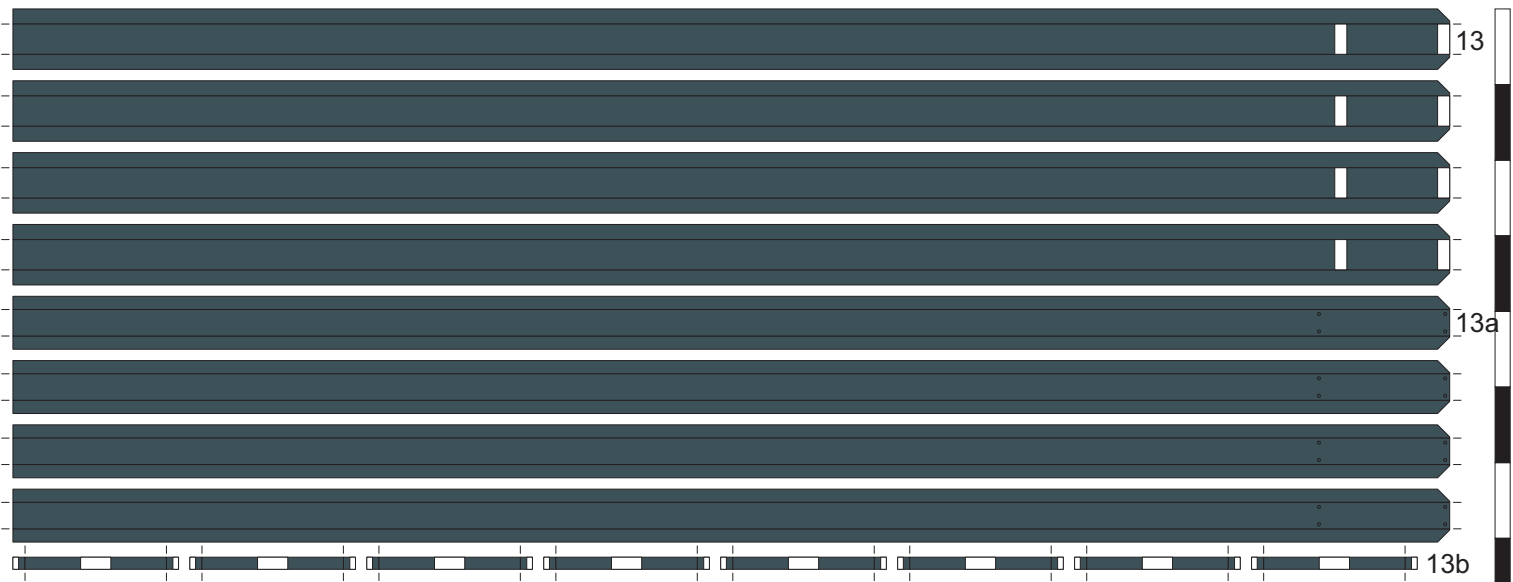

Części dodatkowe do wskaźnika K 8a

Części dodatkowe do wskaźnika K 10

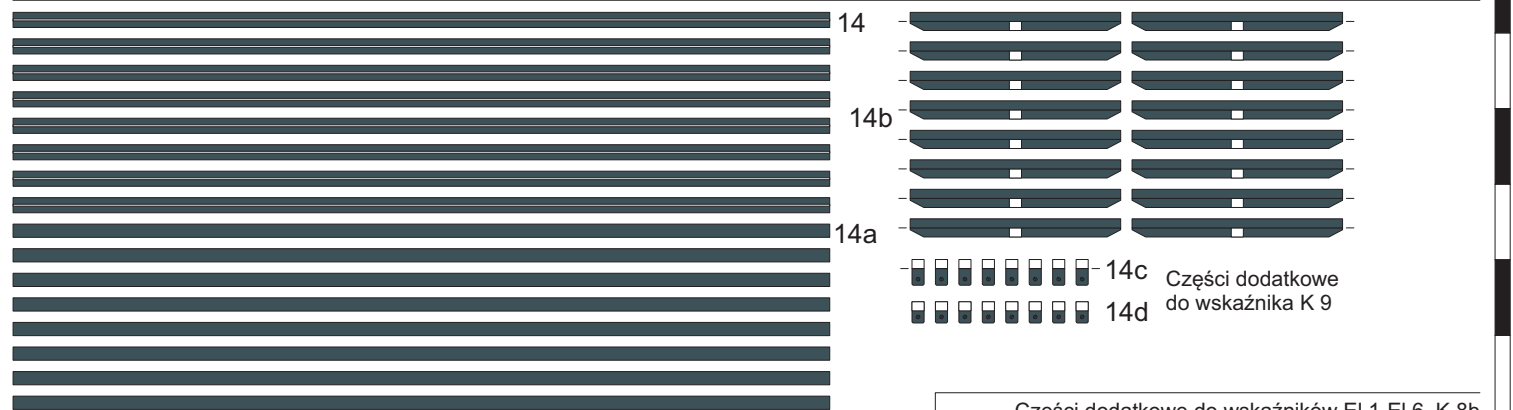

Części dodatkowe do wskaźników EI 1-EI 6, K 8b

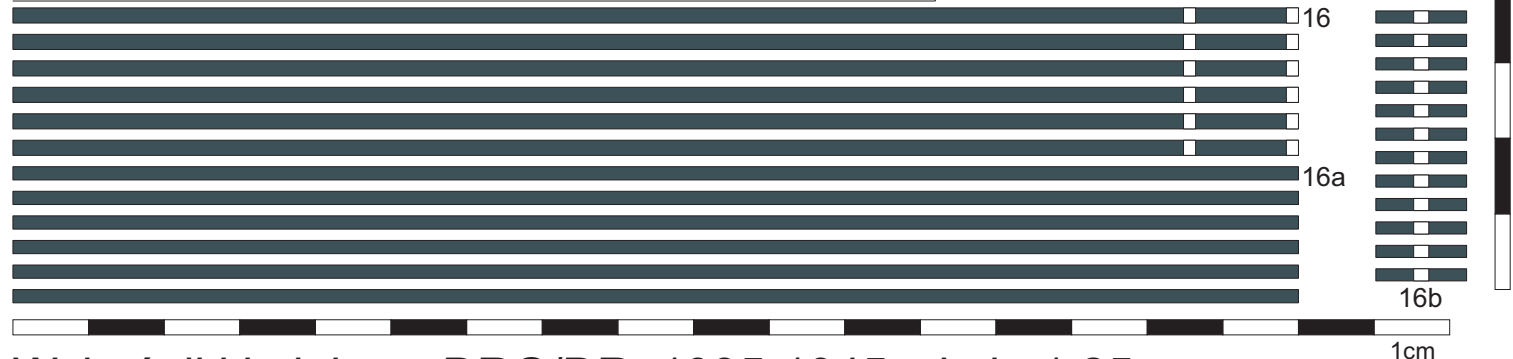

Wskaźniki kolejowe DRG/DR, 1935-1945, skala 1:25

Części dodatkowe

Opracował Paweł Adamowicz (<http://pkprepo.net/>), 2021/2022, niektóre prawa zastrzeżone

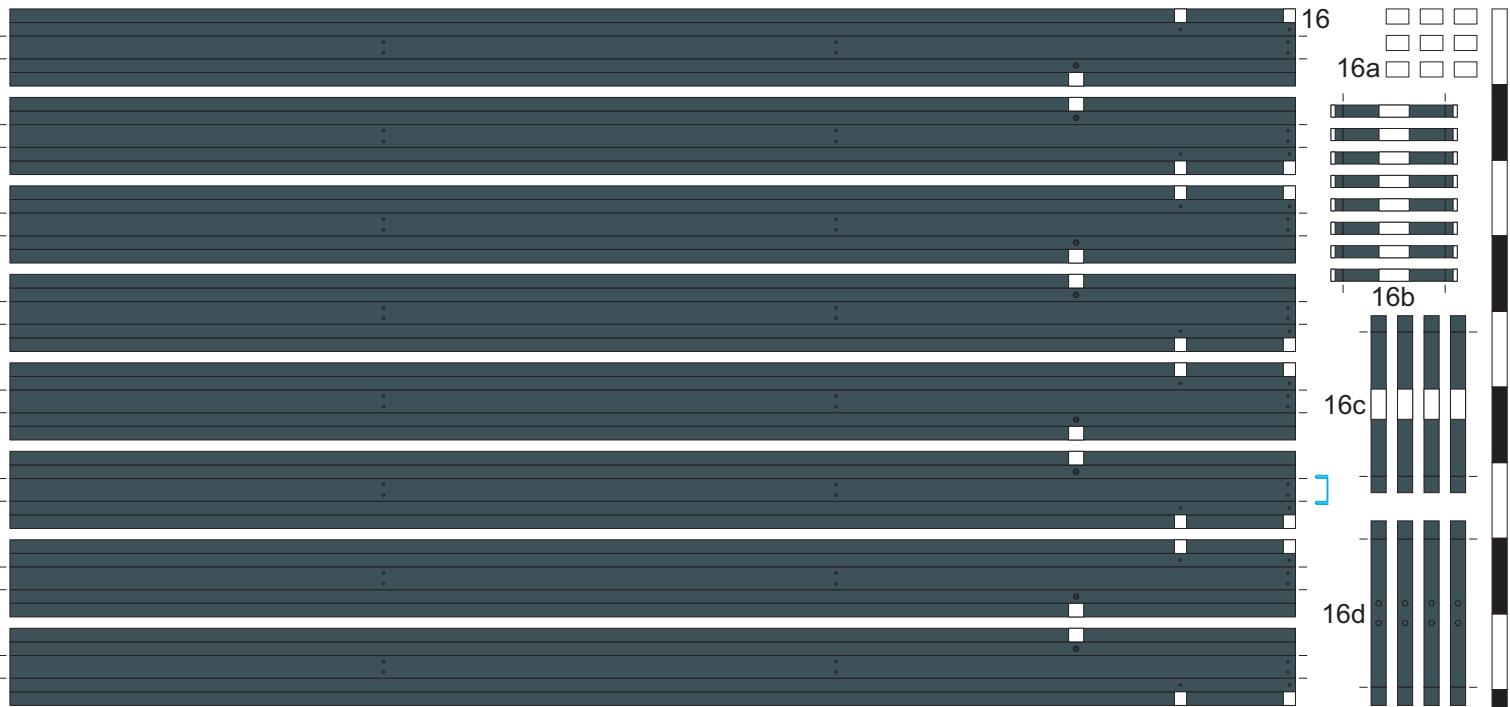

Części dodatkowe do sygnału Ts 1

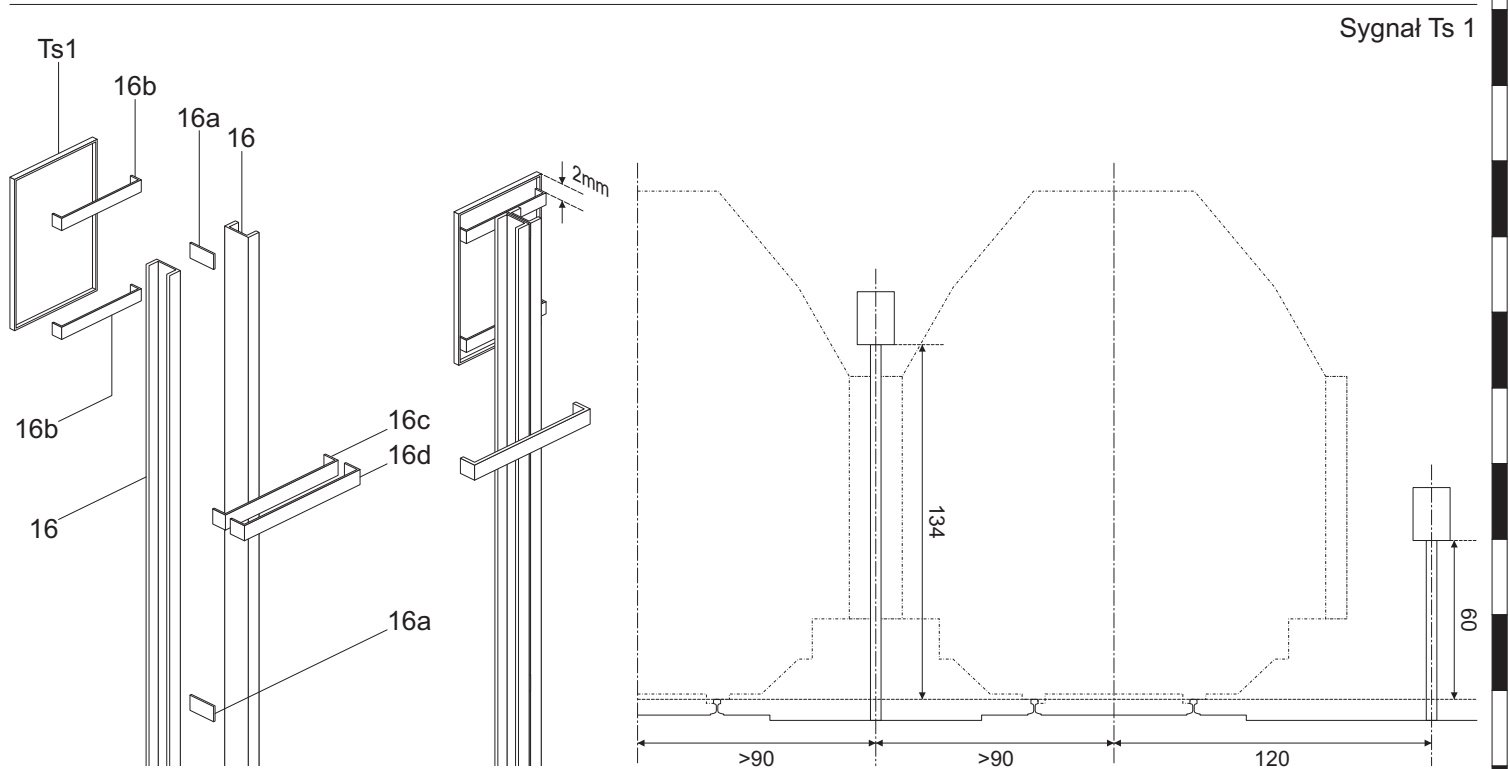

Wskaźniki kolejowe DRG/DR, 1935-1945, skala 1:25

Części dodatkowe, instrukcja sklepania 1/10

Opracował Paweł Adamowicz (<http://pkprepo.net/>), 2021/2022, niektóre prawa zastrzeżone

Sygnal Lf 1

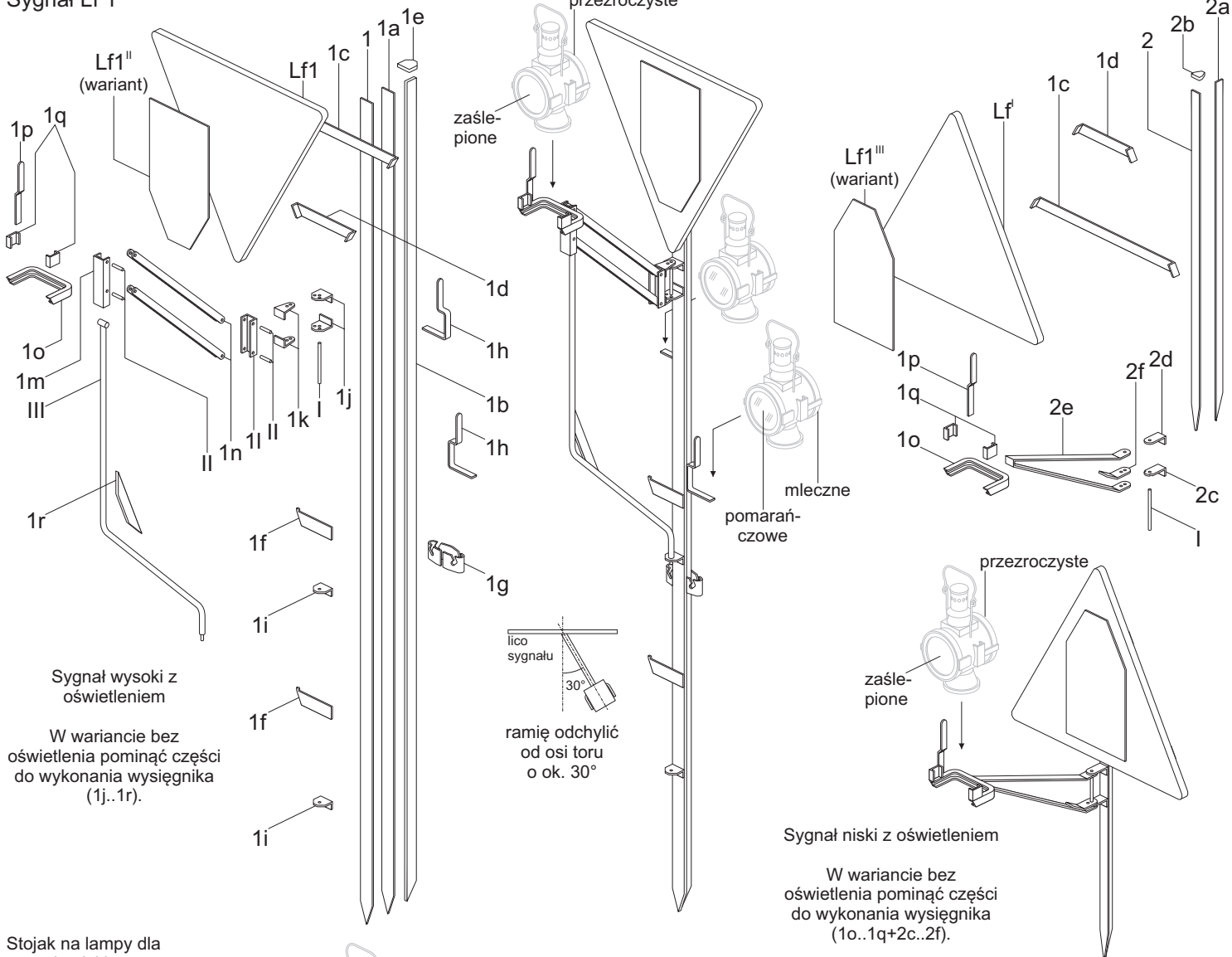

Stojak na lampy dla sygnalu niskiego (ustawić ~150mm przed sygnalem).

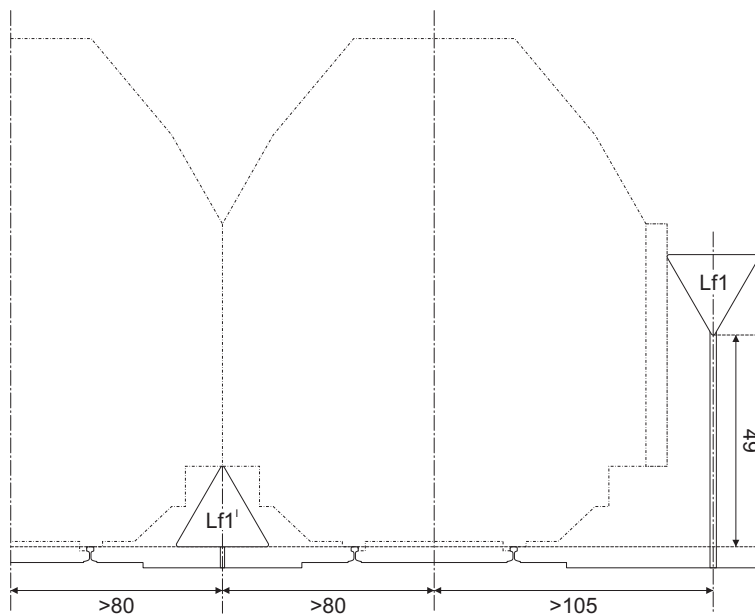
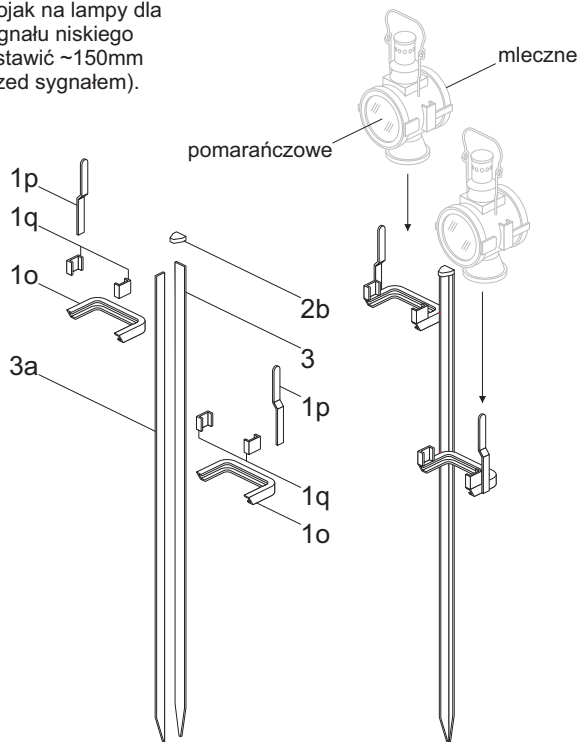

Wskaźniki kolejowe DRG/DR, 1935-1945, skala 1:25

Instrukcja sklejania 2/10

Opracował Paweł Adamowicz (<http://pkprepo.net/>), 2021/2022, niektóre prawa zastrzeżone

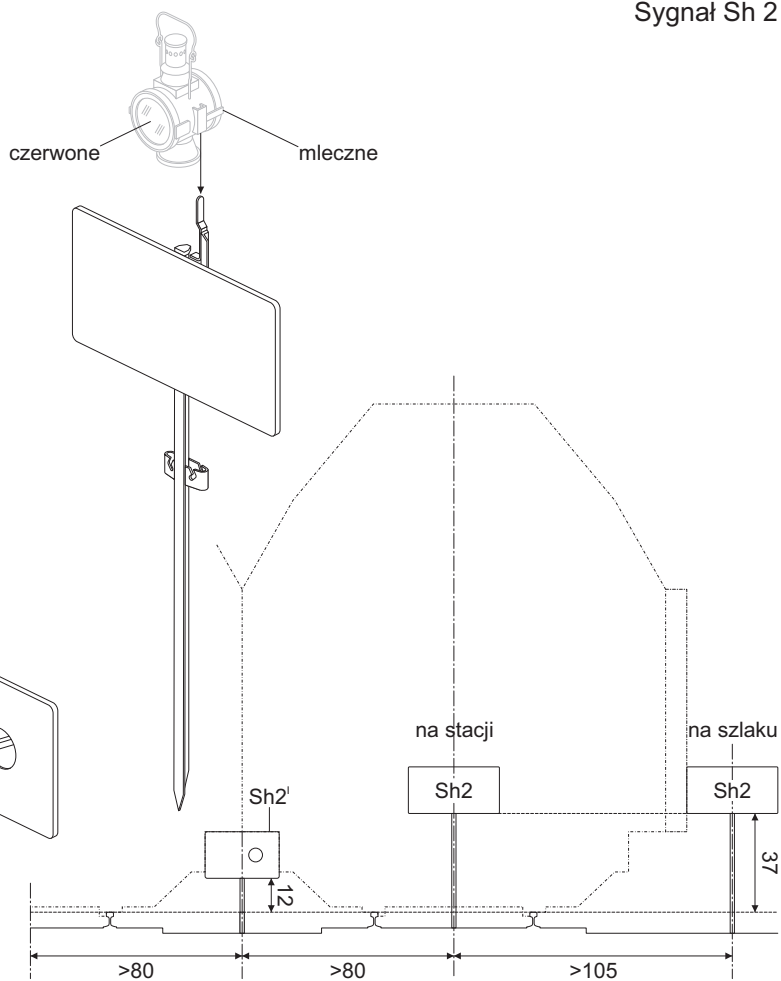
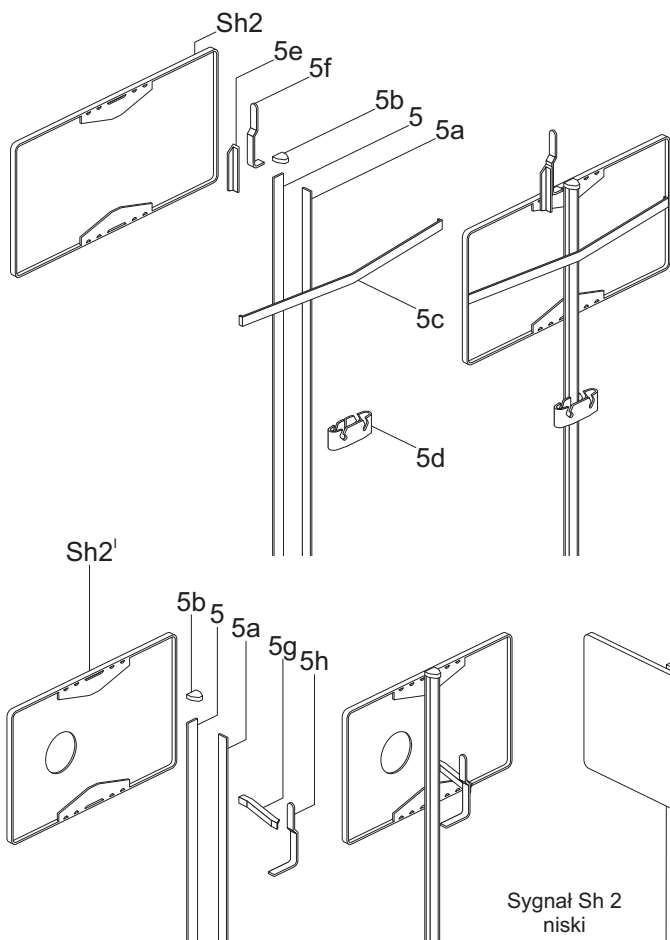
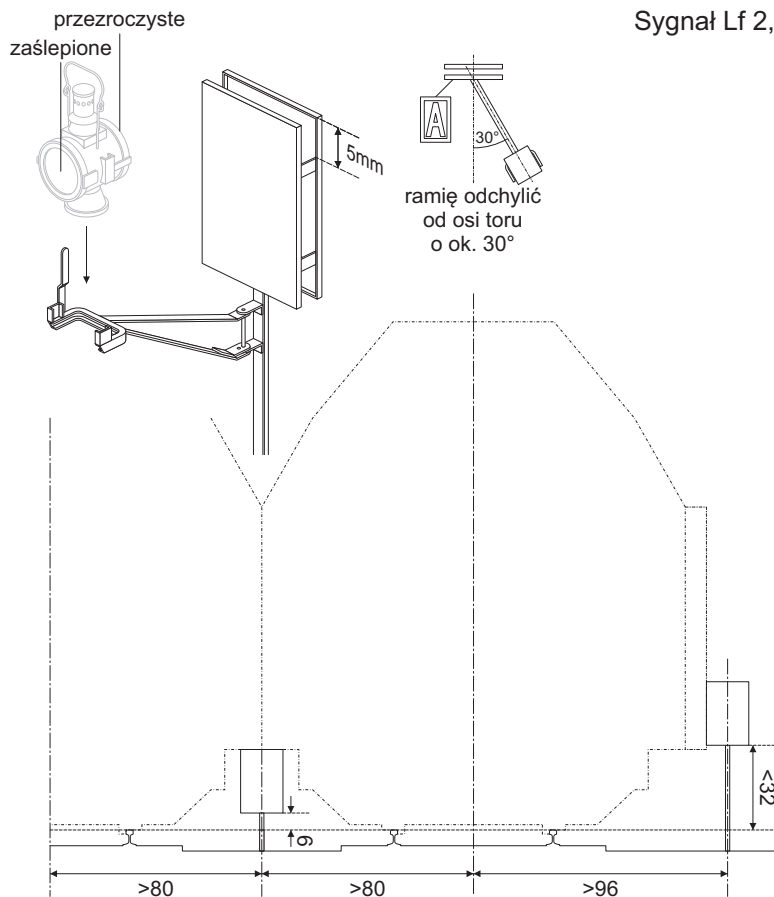
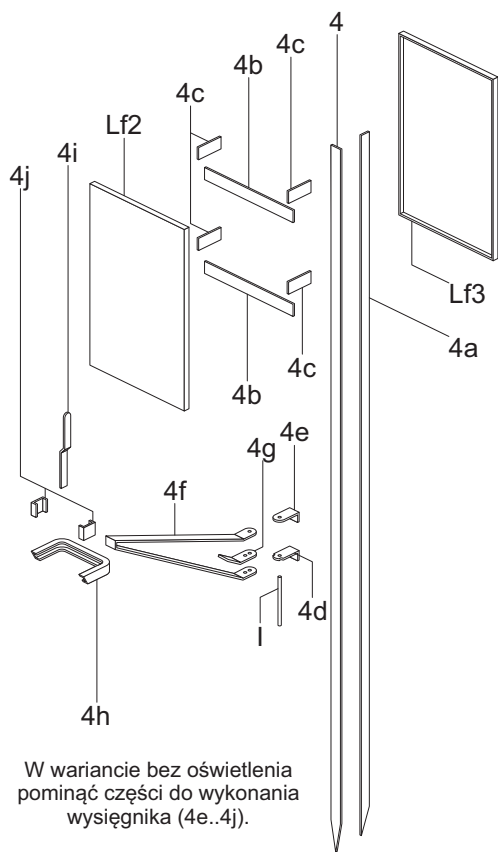

Wskaźniki kolejowe DRG/DR, 1935-1945, skala 1:25

Instrukcja sklejania 3/10

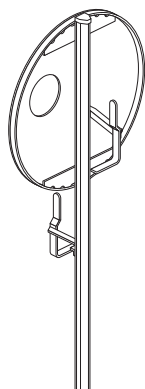
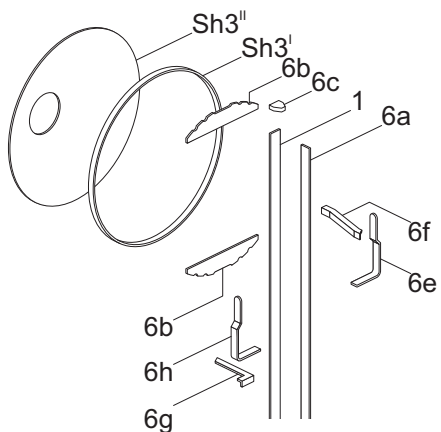
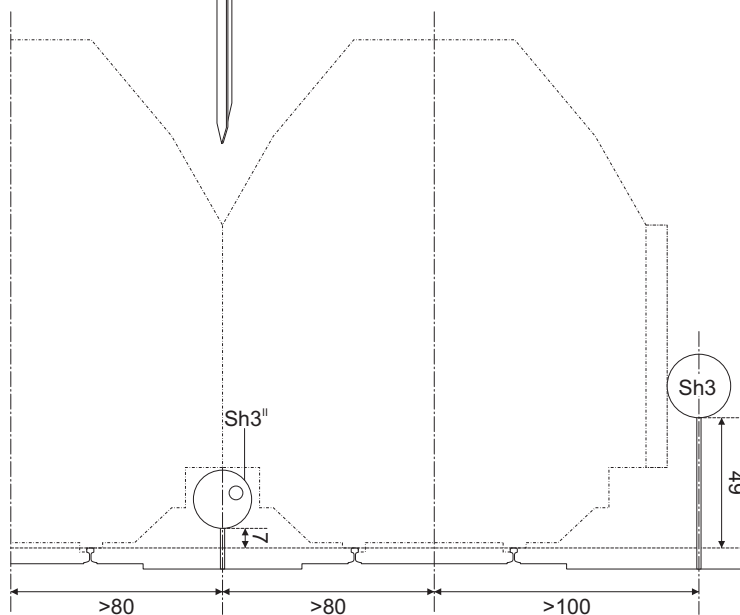
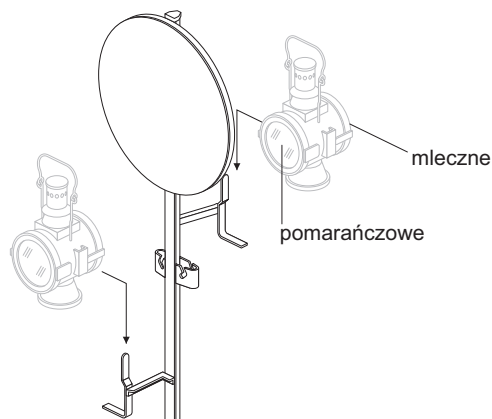
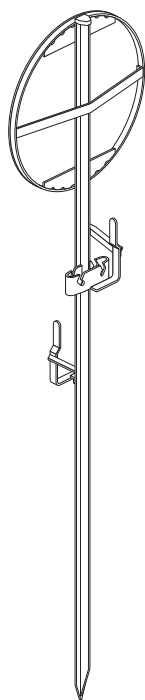
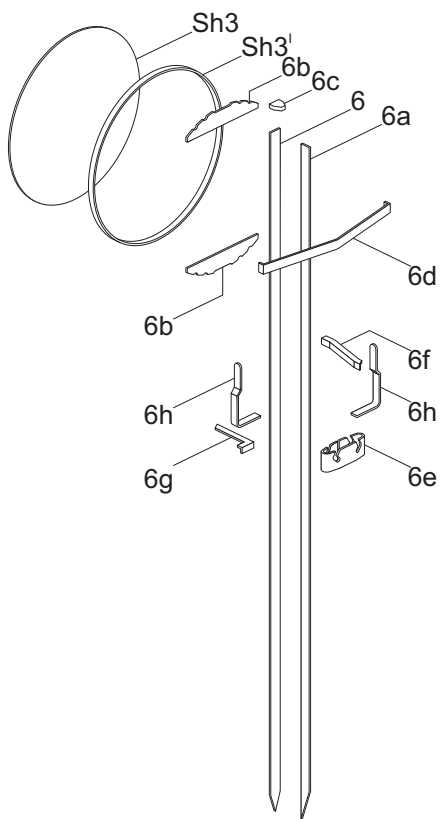

Sygnal Sh 3 niski

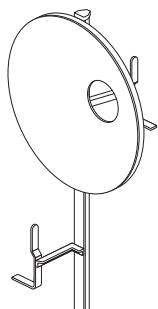

Stelaż do sygnalów
Lf 1, Sh 2, Sh 3
(wariant)

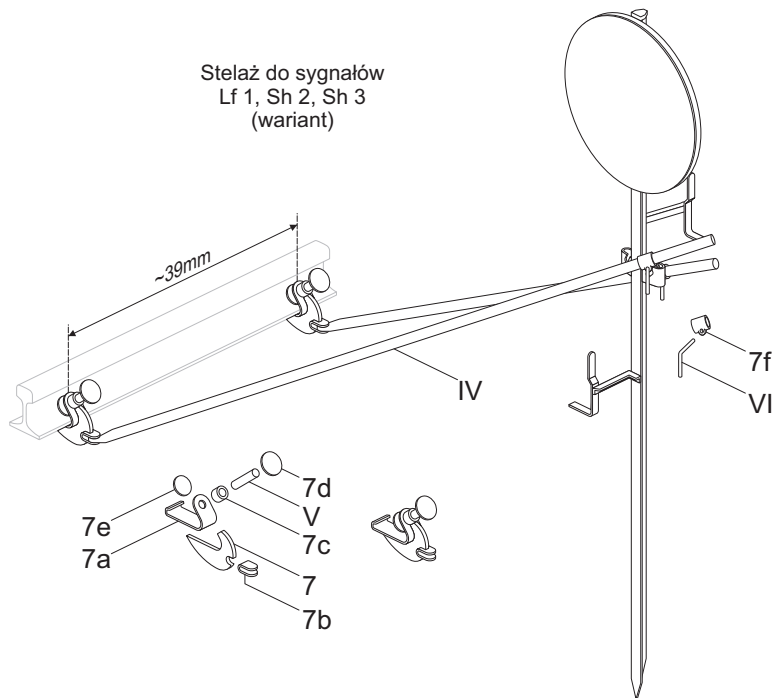

Wskaźniki kolejowe DRG/DR, 1935-1945, skala 1:25

Instrukcja sklejania 4/10

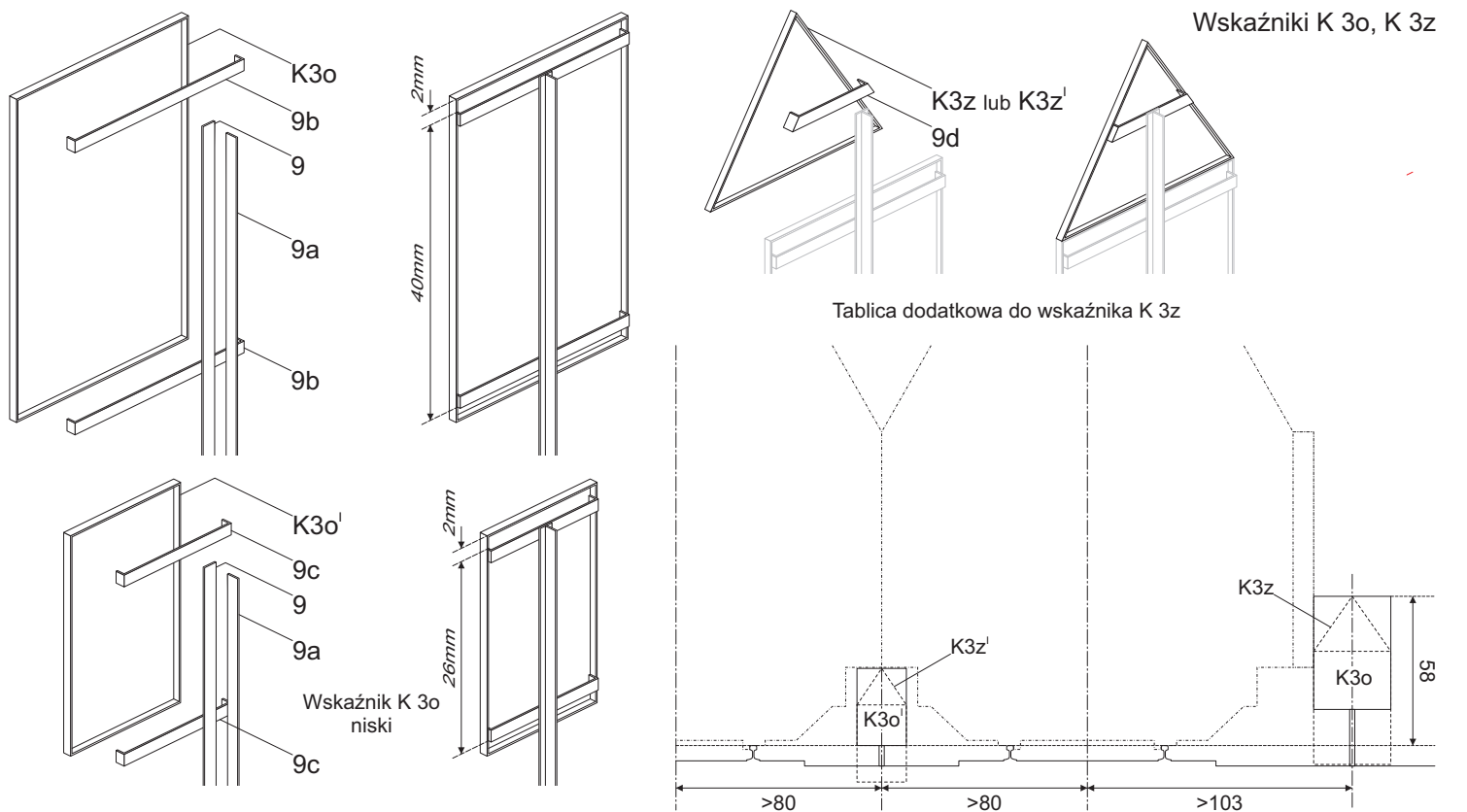
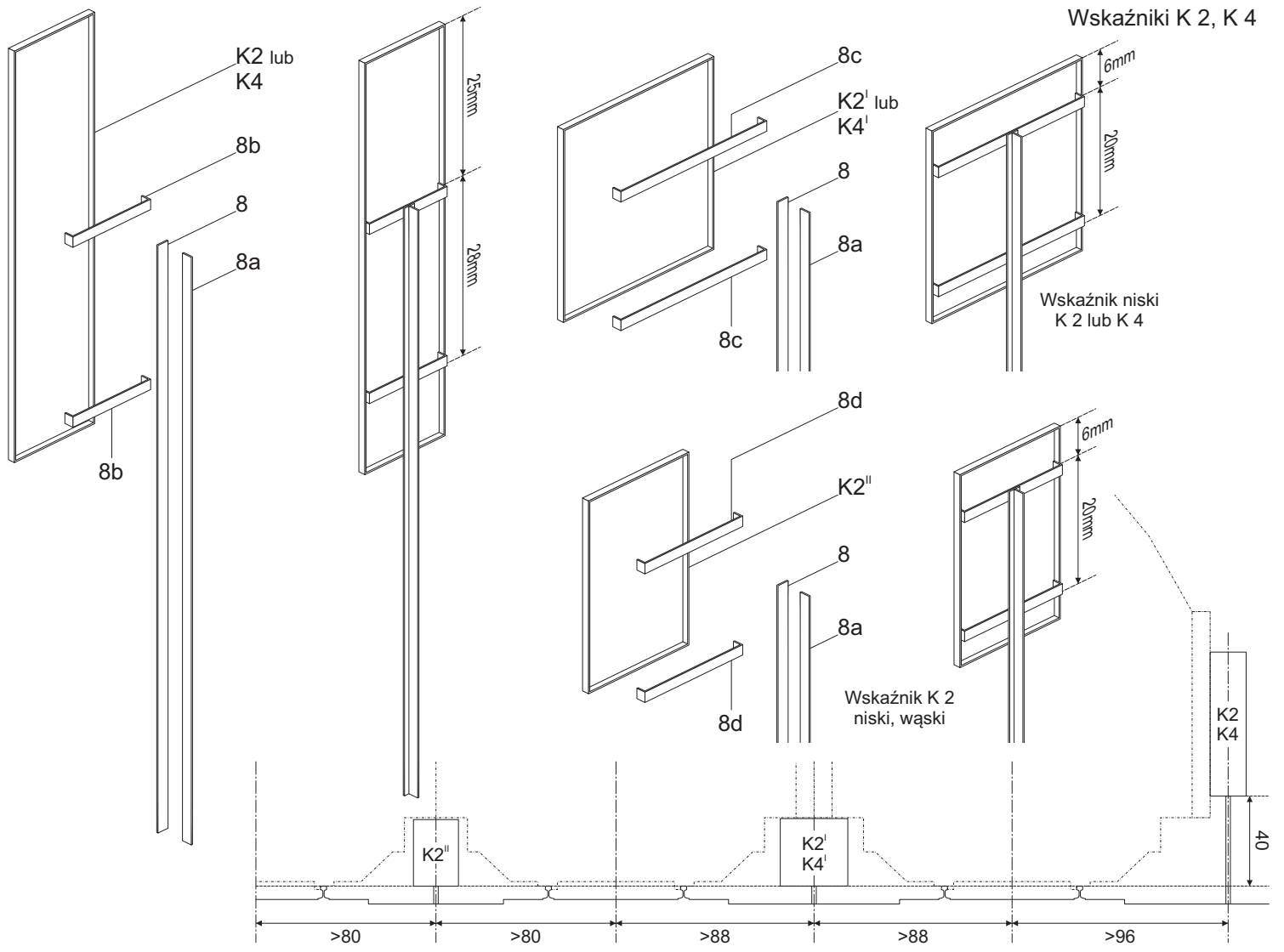

Wskaźniki kolejowe DRG/DR, 1935-1945, skala 1:25

Instrukcja sklejania 5/10

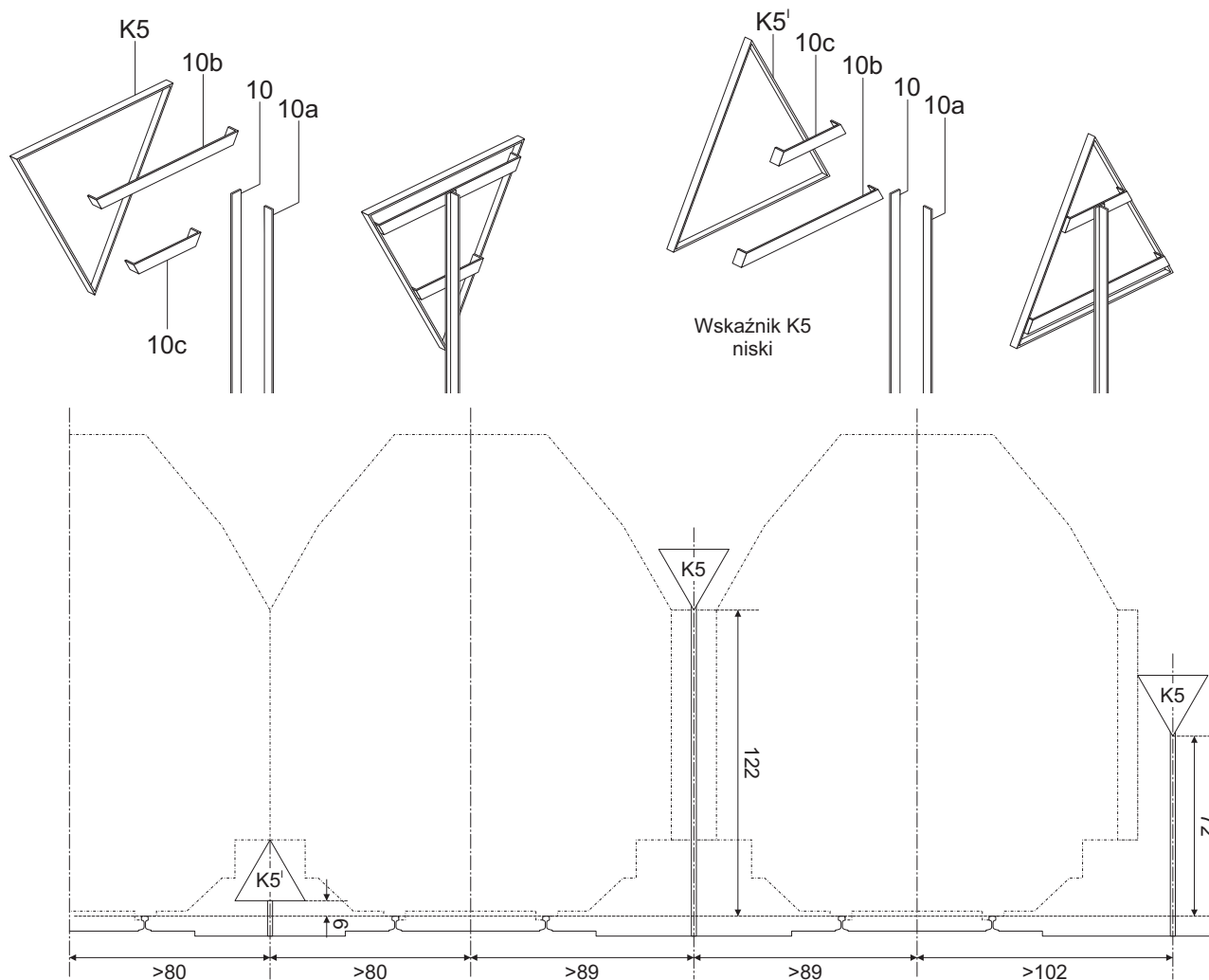

Wskaźnik K5 niski

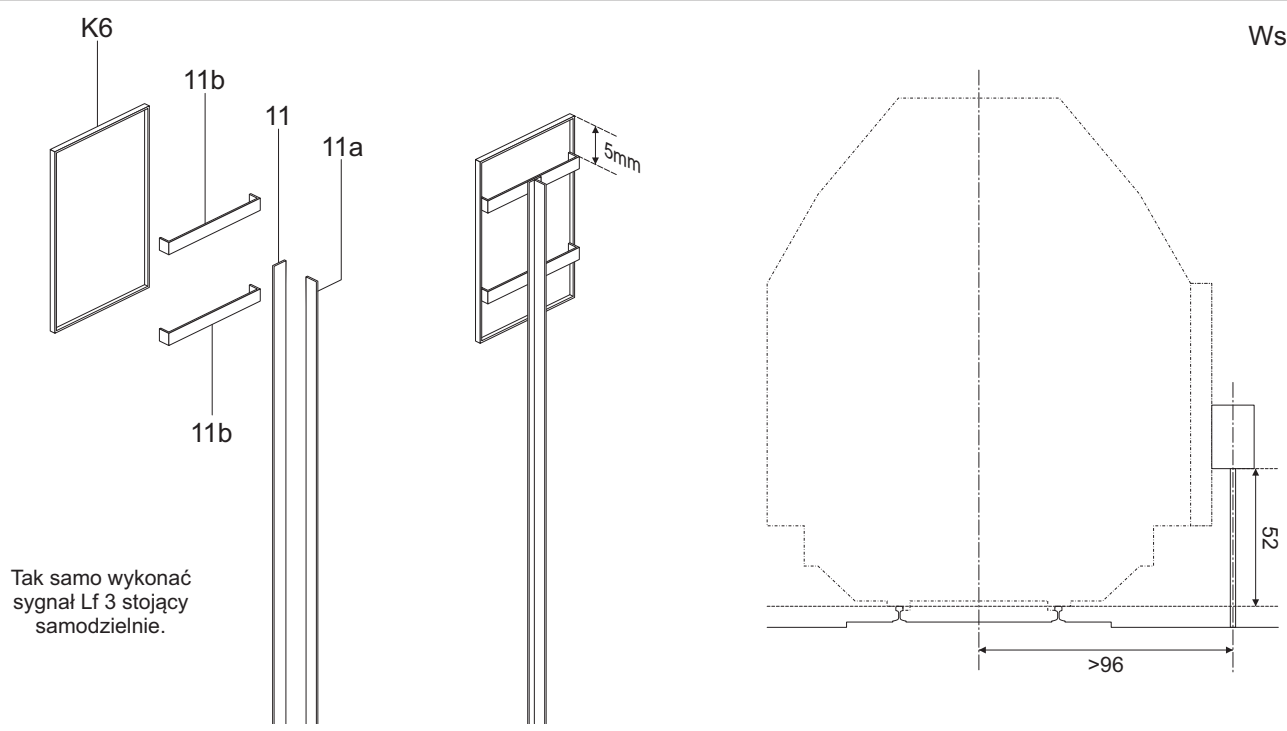

Tak samo wykonać sygnał Lf 3 stojący samodzielnie.

Wskaźniki kolejowe DRG/DR, 1935-1945, skala 1:25

Instrukcja sklejania 6/10

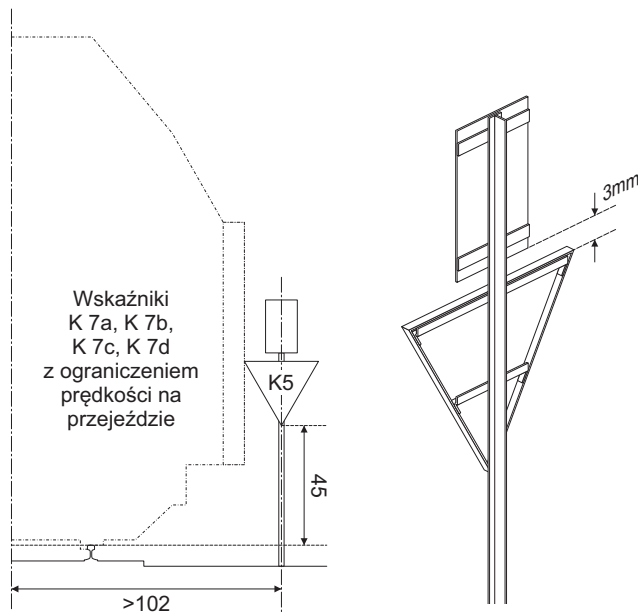
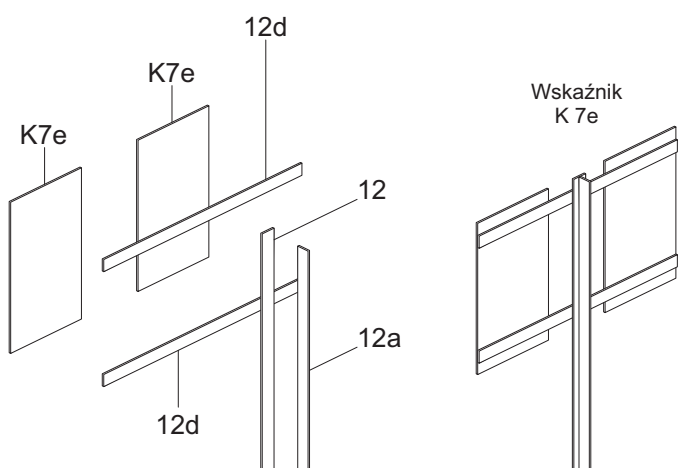
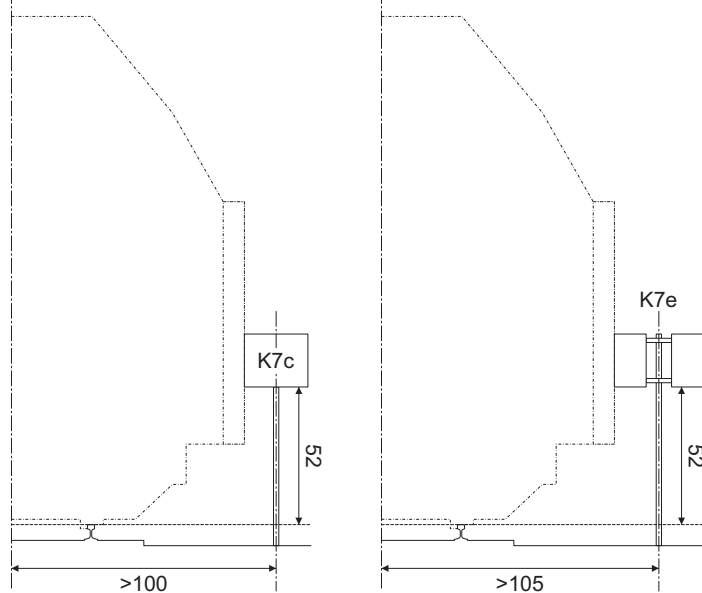
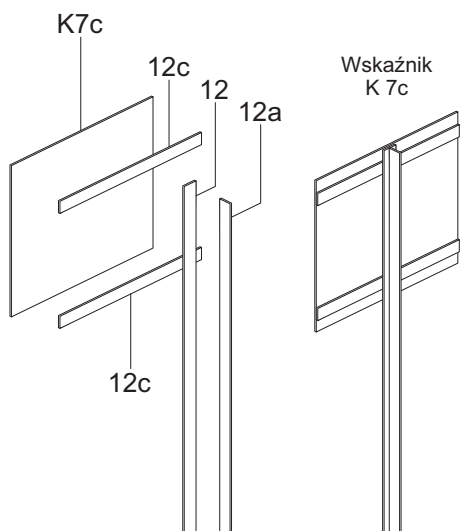
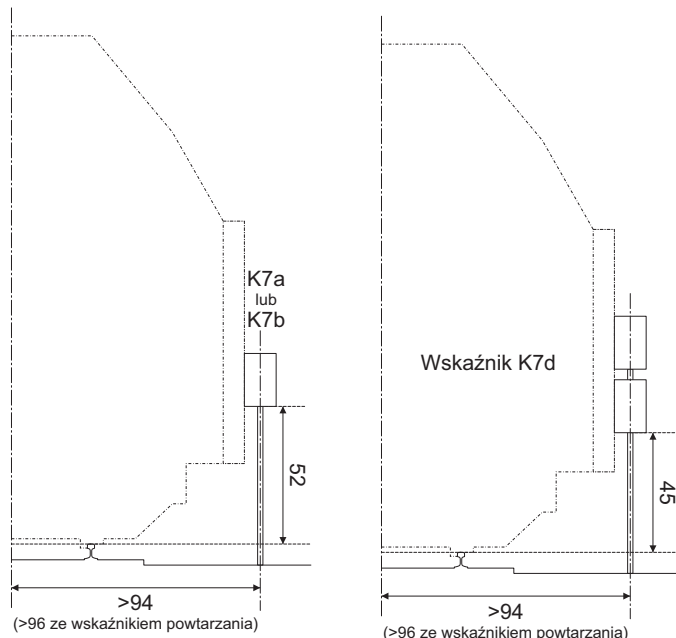
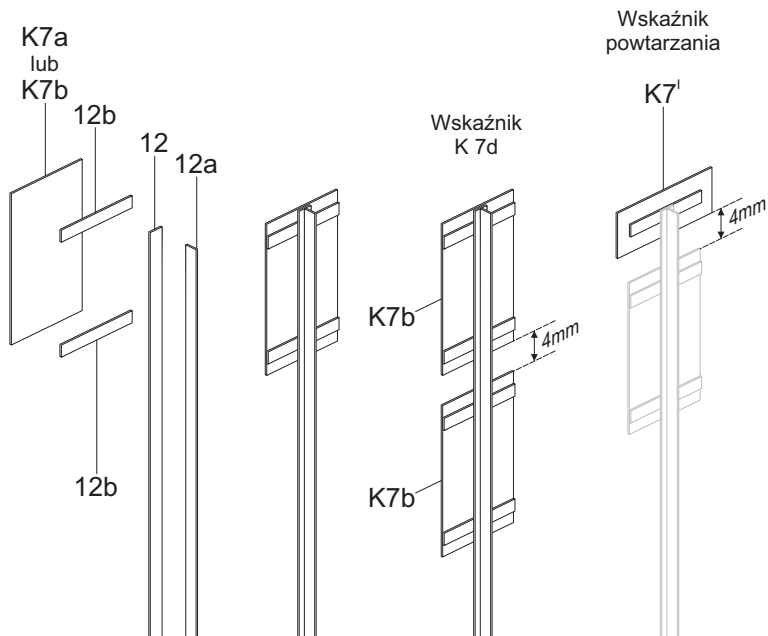

Wskaźniki kolejowe DRG/DR, 1935-1945, skala 1:25

Instrukcja sklejania 7/10

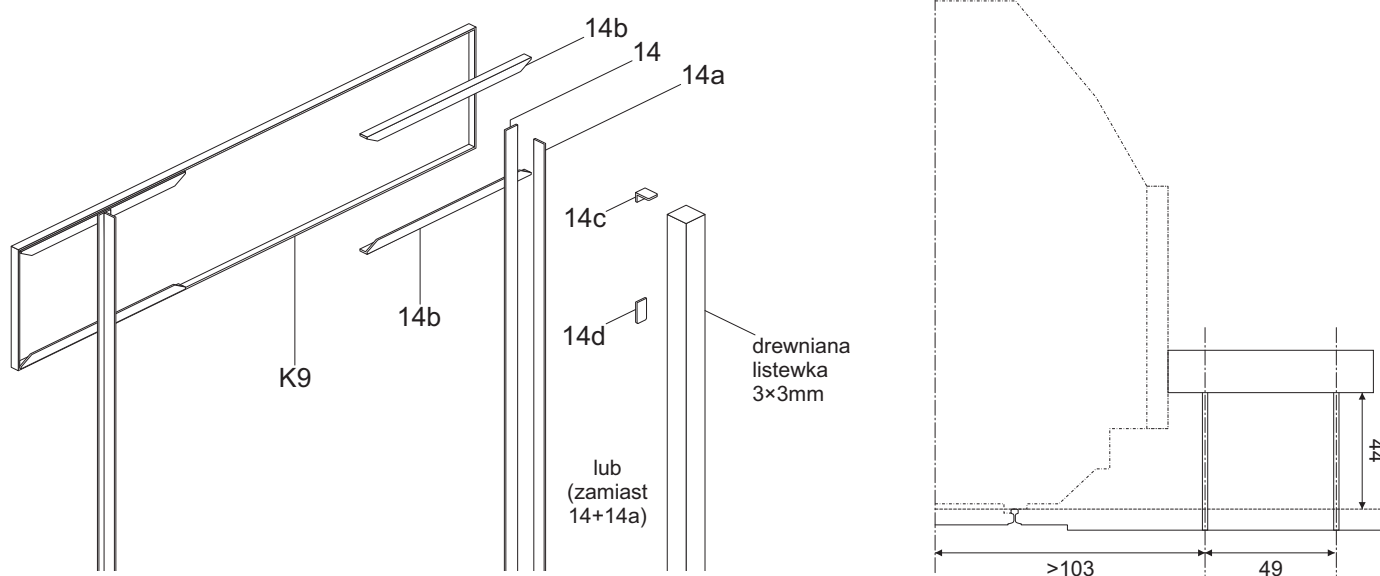
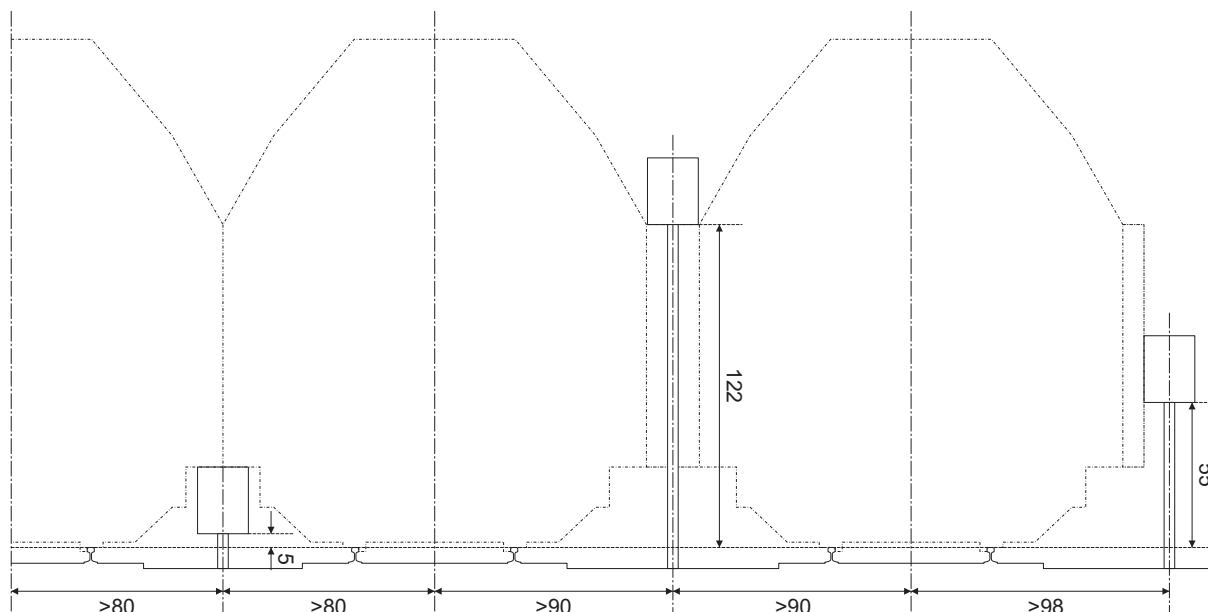
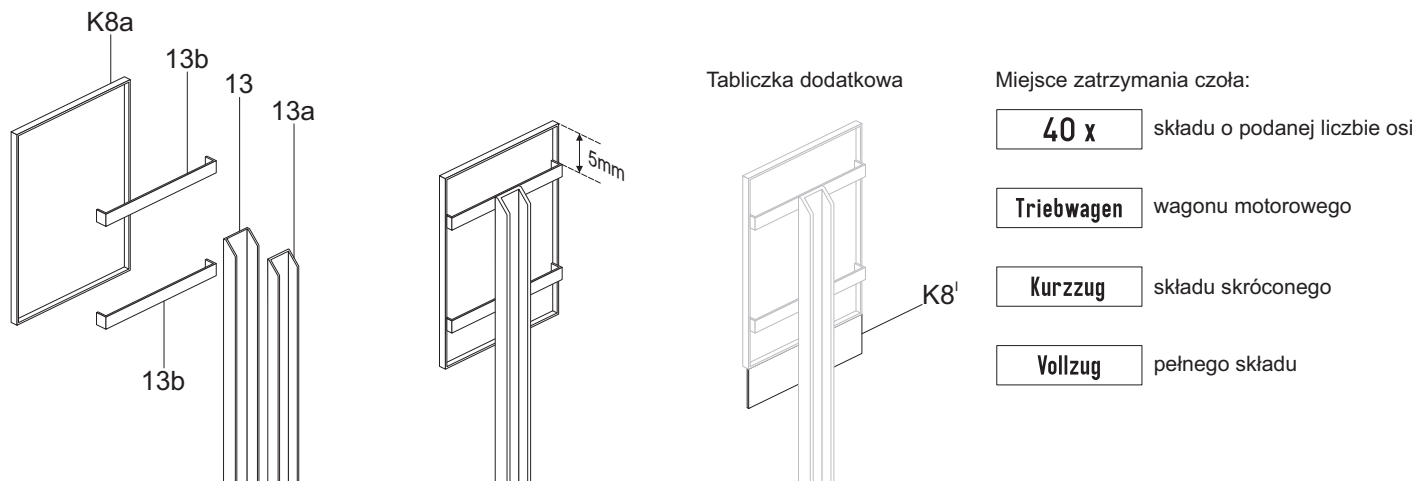

Wskaźniki kolejowe DRG/DR, 1935-1945, skala 1:25

Instrukcja sklejania 8/10

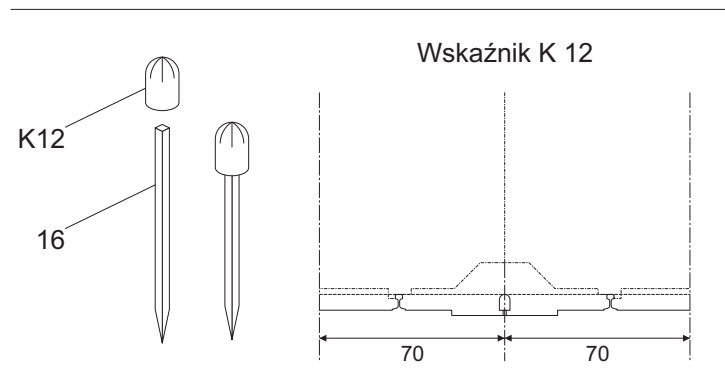
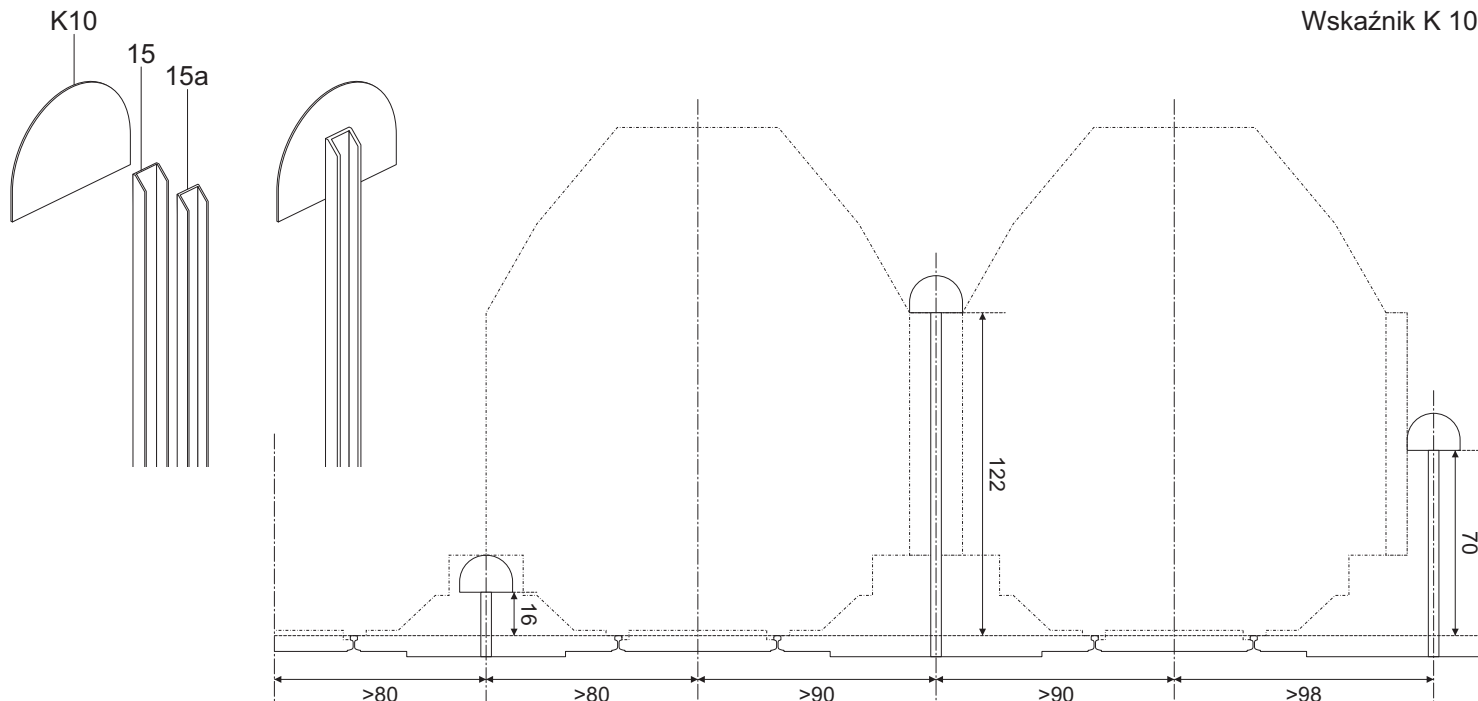

Wskaźnik K 12

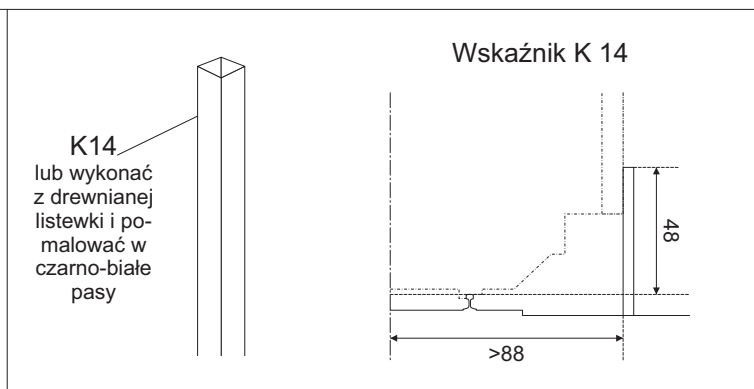

Wskaźnik K 14

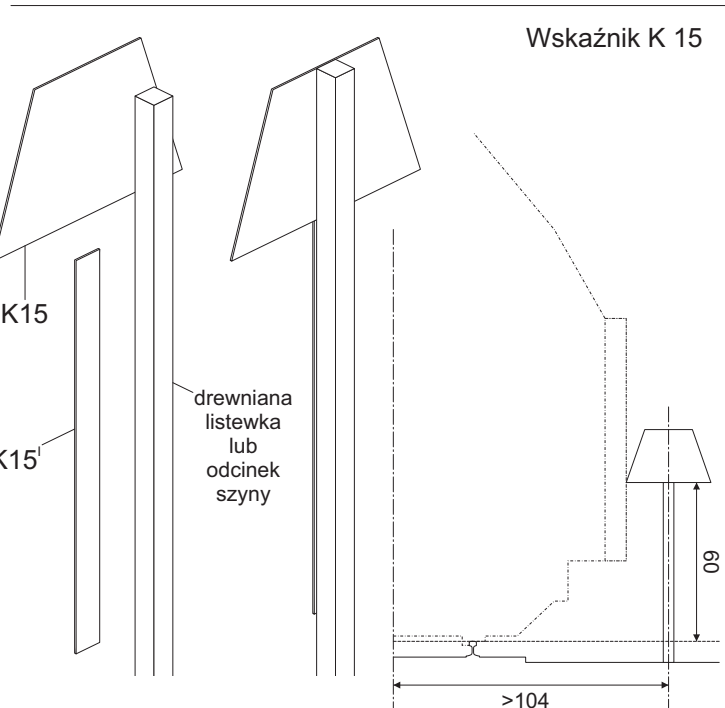

Wskaźnik K 15

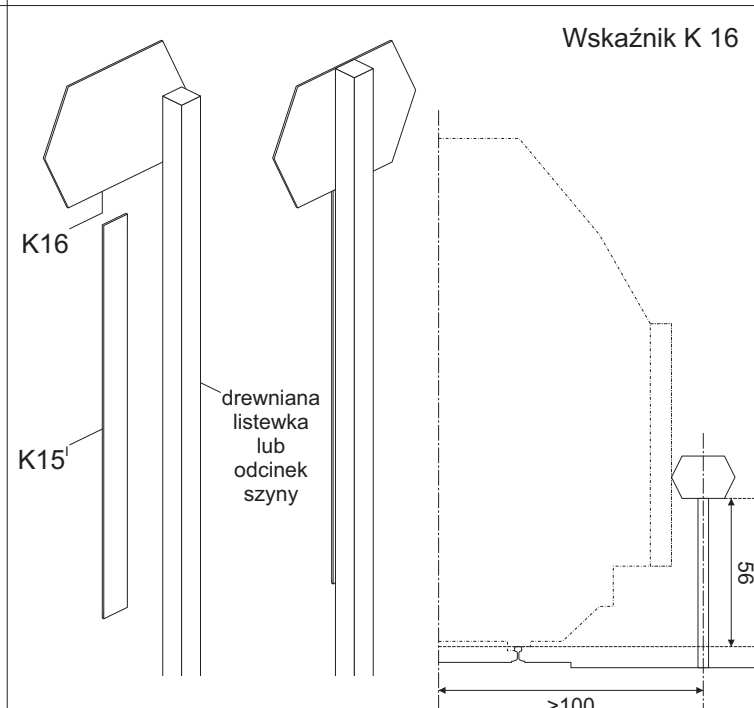

Wskaźnik K 16

Wariant: pominąć cz. K15' i pomalować przód słupka w ukośnię, czarno-białe pasy

Wariant: pominąć cz. K15' i pomalować przód słupka w ukośnię, czarno-białe pasy

Wskaźniki kolejowe DRG/DR, 1935-1945, skala 1:25

Instrukcja sklejania 9/10

Wskaźnik K 17

Tabliczka "M"

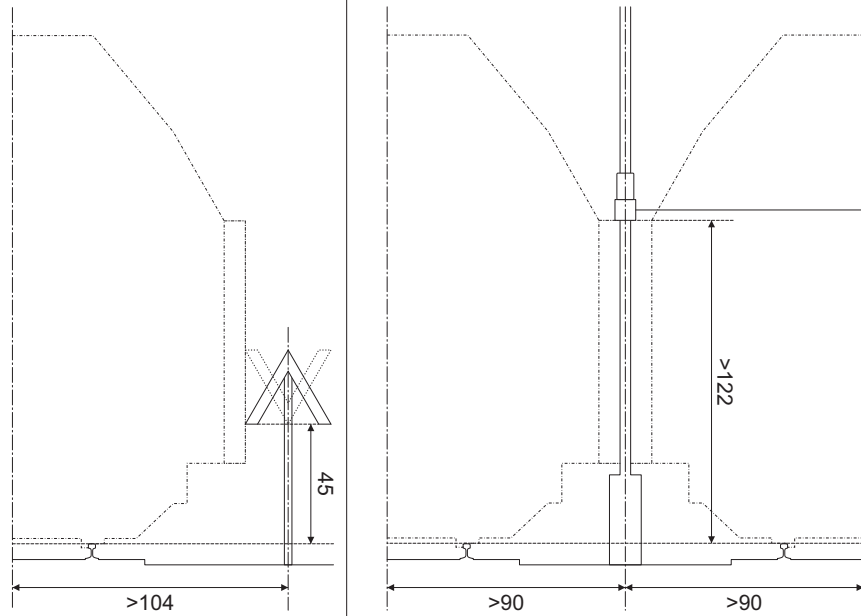
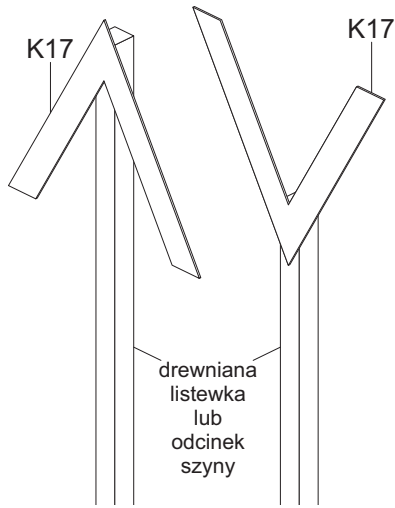

Mt
(umieścić pod tabliczką z oznakowaniem semafora)

Wskaźniki dla linii zelektryfikowanych EI 1-EI 6, K 8b

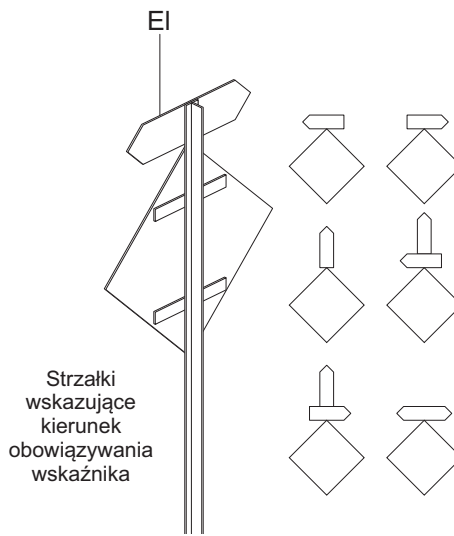
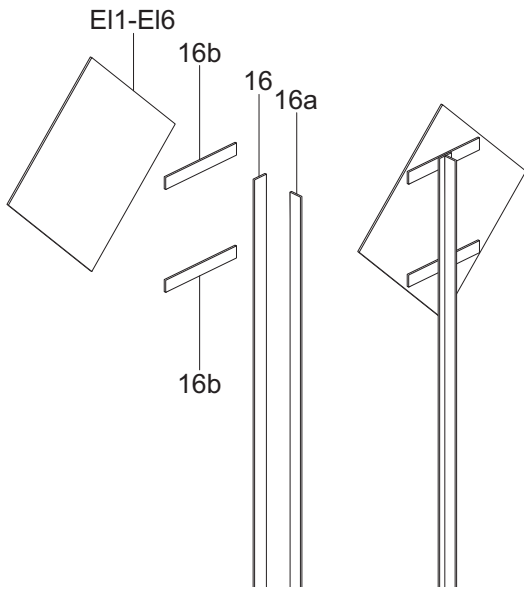

Strzałki wskazujące kierunek obowiązywania wskaźnika

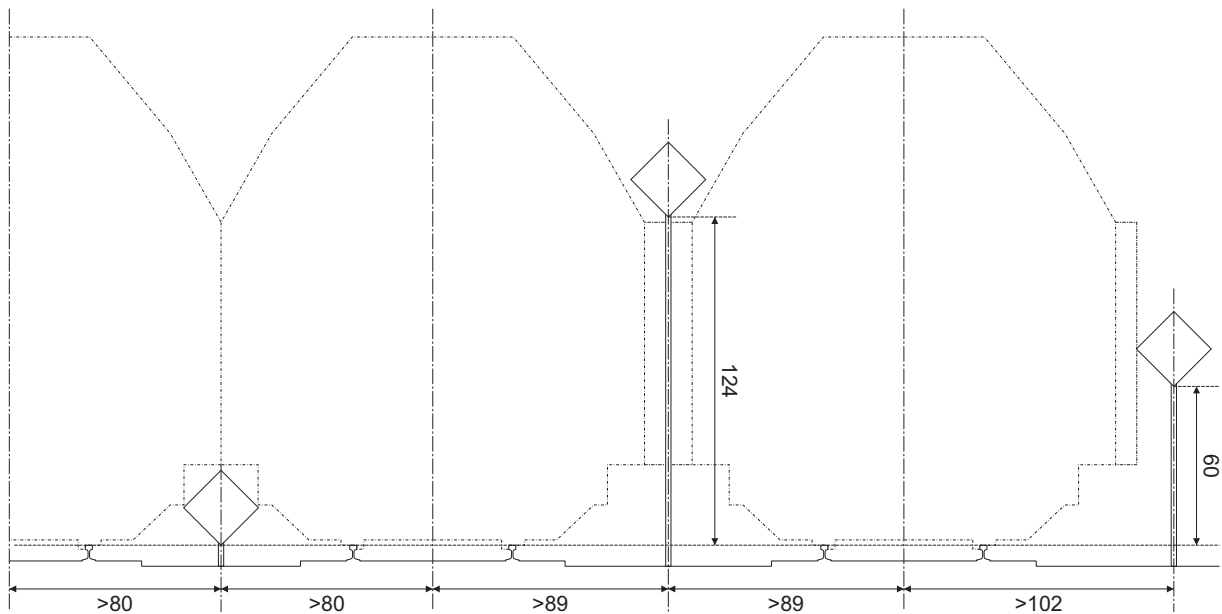
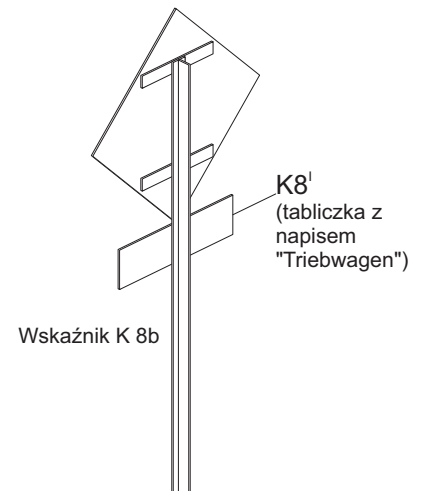

Wskaźniki kolejowe DRG/DR, 1935-1945, skala 1:25

Instrukcja sklejania 10/10