

3e (ozn. tarczy niemieckiej)

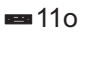

Elementy napędu elektrycznego

3f (tabl. z numerem tarczy)

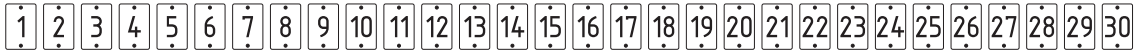

Szablony do samodzielnego wykonania elementów:

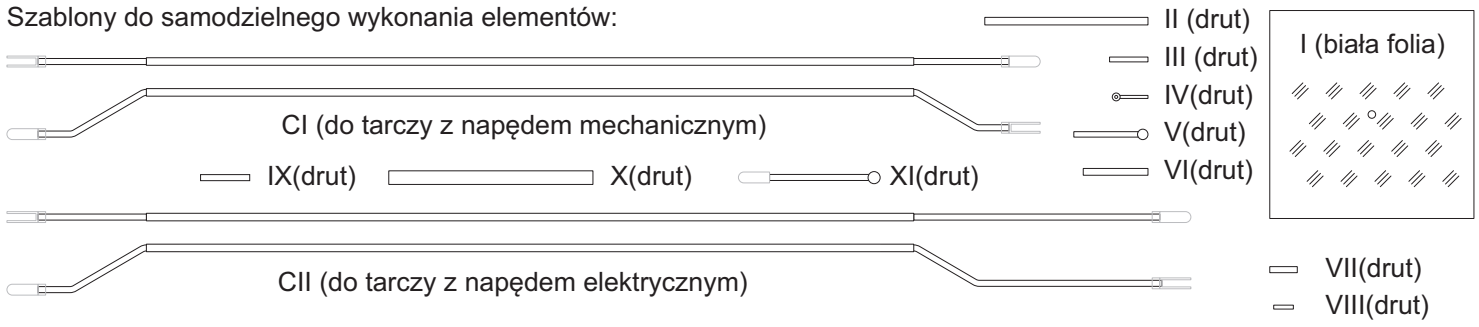

Tarcza zaporowa PKP, skala 1:25

1cm

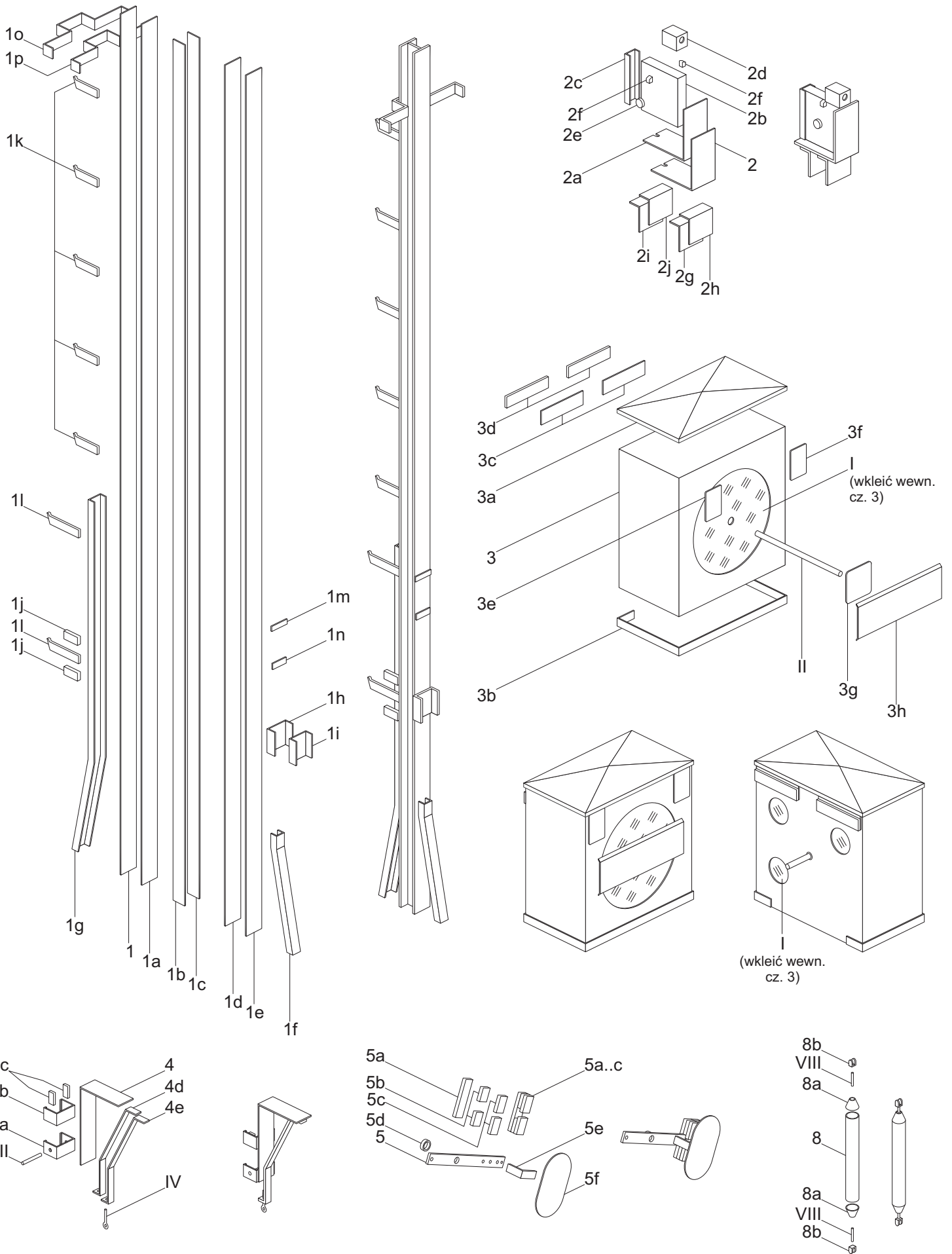

Tarcza zaporowa PKP, skala 1:25

Instrukcja sklejania 1/3

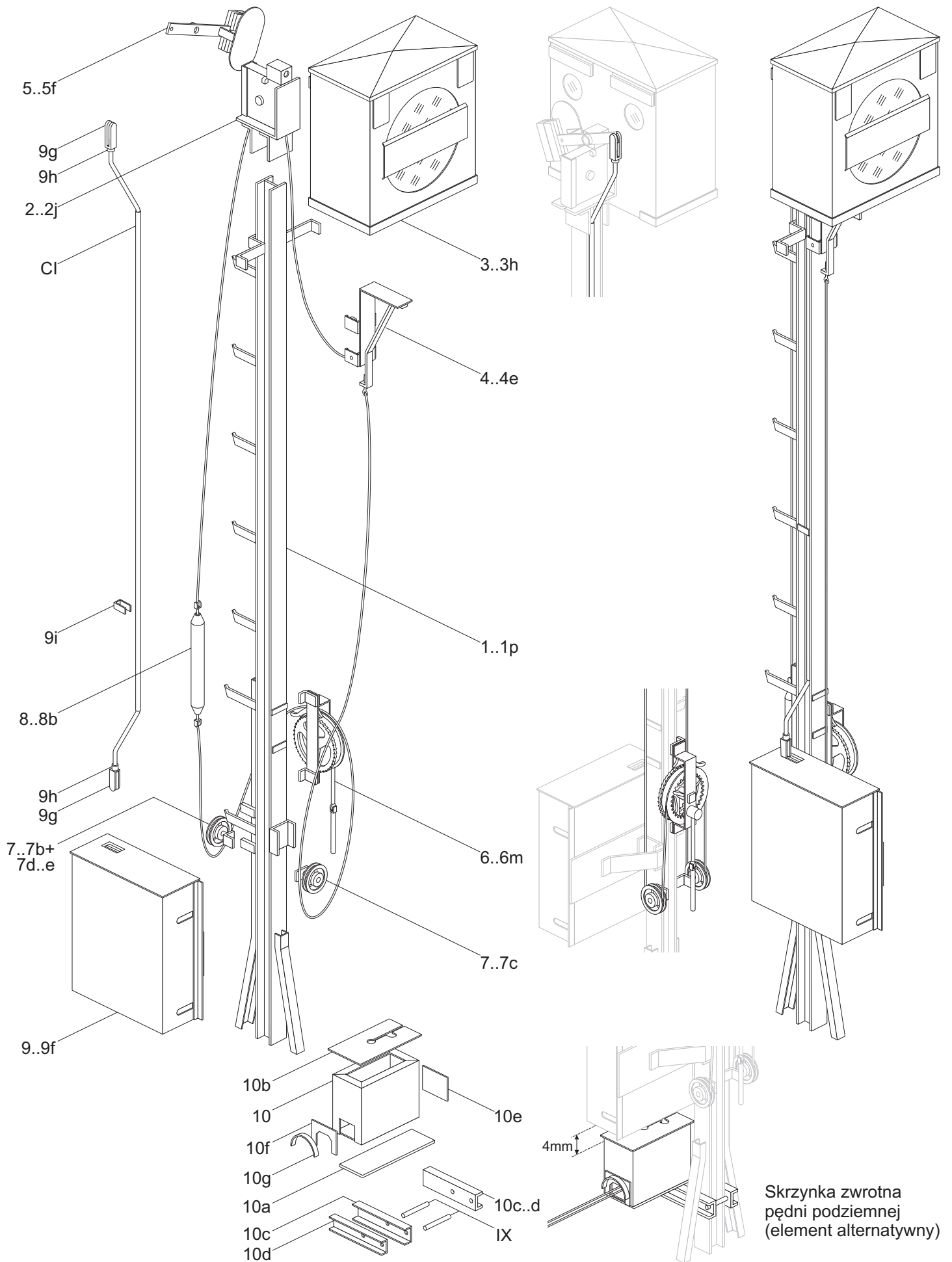

Tarcza zaporowa PKP, skala 1:25

Instrukcja sklejania 2/3

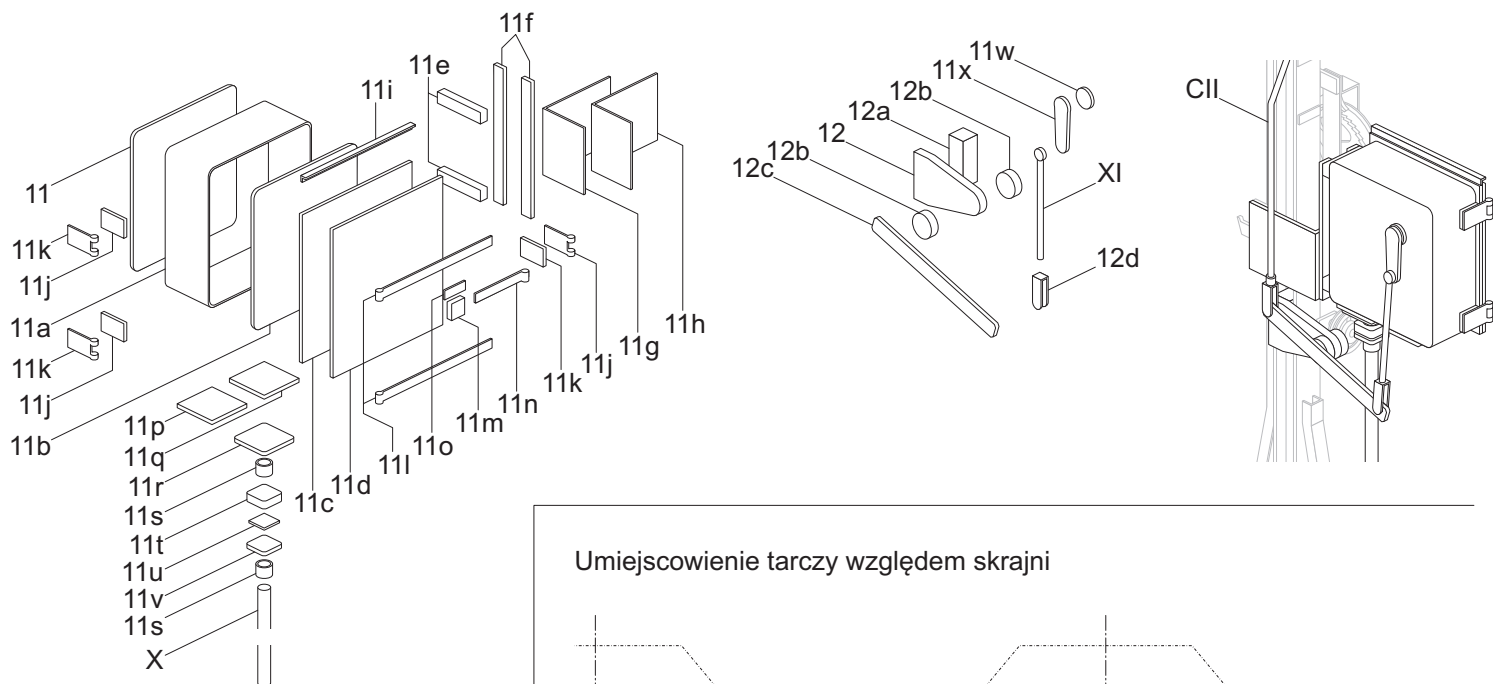
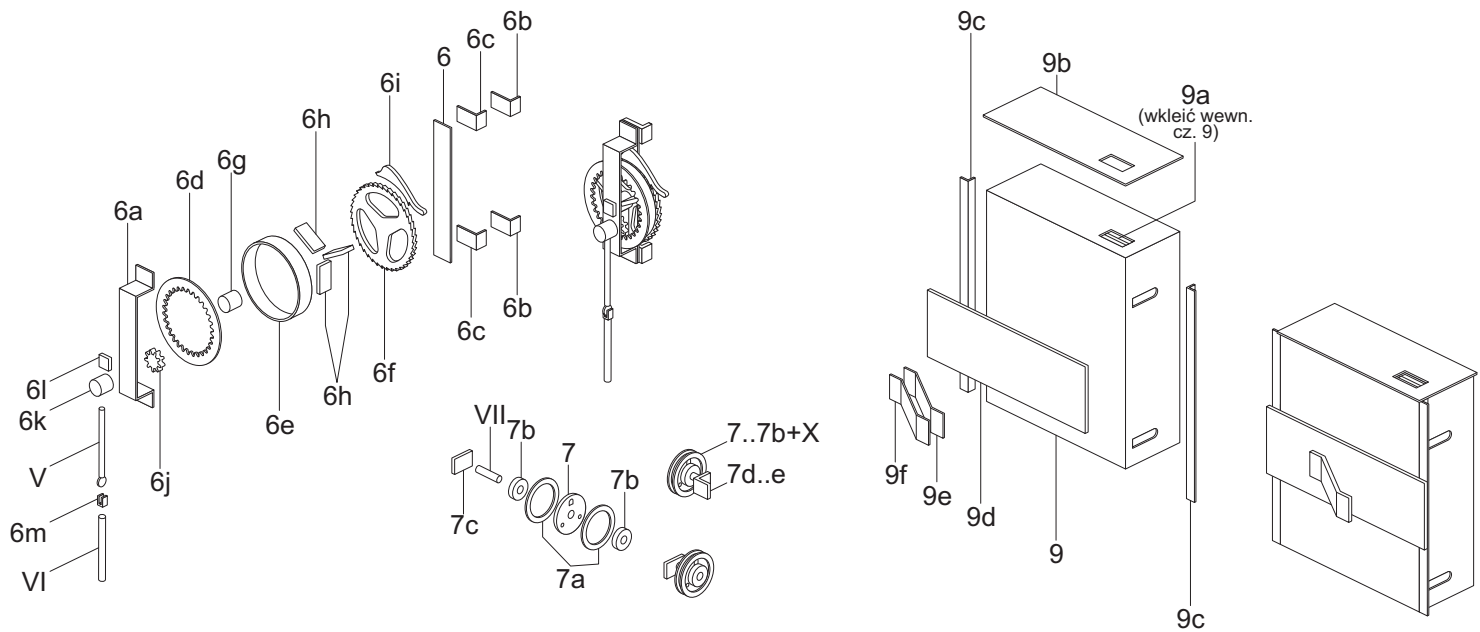

Napęd elektryczny tarczy
(wykonanie alternatywne - zamiast cz. 9..9f)

Umieszczenie tarczy względem skrajni

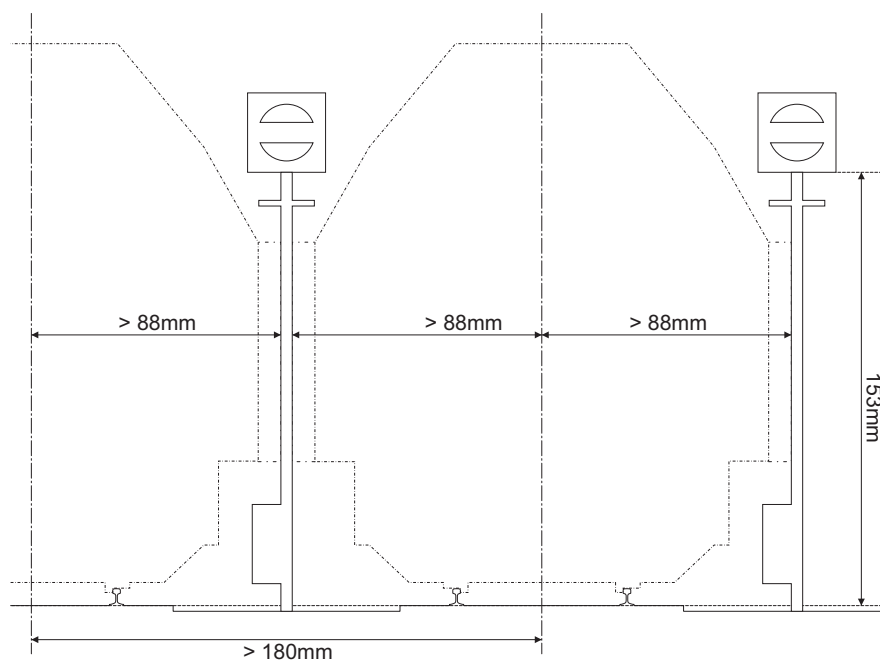

Tarcza zaporowa PKP, skala 1:25

Instrukcja sklejania 3/3