

Tarcza ostrzegawcza przejazdowa PKP, skala 1:25

10	10N	40	40N	70	70N	100	100N	130	130N	160	160N	190	190N
11	11N	41	41N	71	71N	101	101N	131	131N	161	161N	191	191N
12	12N	42	42N	72	72N	102	102N	132	132N	162	162N	192	132N
13	13N	43	43N	73	73N	103	103N	133	133N	163	163N	193	193N
14	14N	44	44N	74	74N	104	104N	134	134N	164	164N	194	194N
15	15N	45	45N	75	75N	105	105N	135	135N	165	165N	195	195N
16	16N	46	46N	76	76N	106	106N	136	136N	166	166N	196	196N
17	17N	47	47N	77	77N	107	107N	137	137N	167	167N	197	197N
18	18N	48	48N	78	78N	108	108N	138	138N	168	168N	198	198N
19	19N	49	49N	79	79N	109	109N	139	139N	169	179N	199	199N
20	20N	50	50N	80	80N	110	110N	140	140N	170	170N	200	200N
21	21N	51	51N	81	81N	111	111N	141	141N	171	171N	201	201N
22	22N	52	52N	82	82N	112	112N	142	142N	172	172N	202	202N
23	23N	53	53N	83	83N	113	113N	143	143N	173	173N	203	203N
24	24N	54	54N	84	84N	114	114N	144	144N	174	174N	204	204N
25	25N	55	55N	85	85N	115	115N	145	145N	175	175N	205	205N
26	26N	56	56N	86	86N	116	116N	146	146N	176	176N	206	206N
27	27N	57	57N	87	87N	117	117N	147	147N	177	177N	207	207N
28	28N	58	58N	88	88N	118	118N	148	148N	178	178N	208	208N
29	29N	59	59N	89	89N	119	119N	149	149N	179	179N	209	209N
30	30N	60	60N	90	90N	120	120N	150	150N	180	180N	210	210N
31	31N	61	61N	91	91N	121	121N	151	151N	181	181N	211	211N
32	32N	62	62N	92	92N	122	122N	152	152N	182	182N	212	212N
33	33N	63	63N	93	93N	123	123N	153	153N	183	183N	213	213N
34	34N	64	64N	94	94N	124	124N	154	154N	184	184N	214	214N
35	35N	65	65N	95	95N	125	125N	155	155N	185	185N	215	215N
36	36N	66	66N	96	96N	126	126N	156	156N	186	186N	216	216N
37	37N	67	67N	97	97N	127	127N	157	157N	187	187N	217	217N
38	38N	68	68N	98	98N	128	128N	158	158N	188	188N	218	218N
39	39N	69	69N	99	99N	129	129N	159	159N	189	189N	219	219N

Szablony

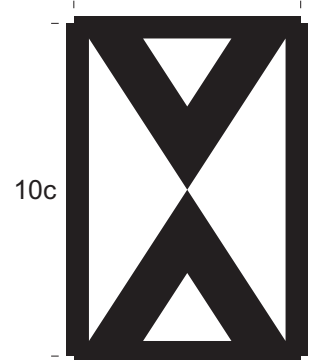
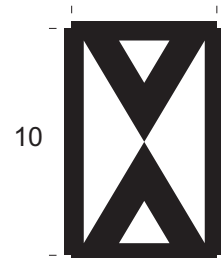
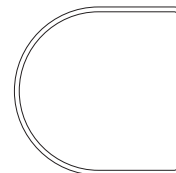
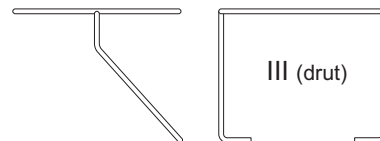
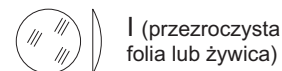

Tabliczki z oznaczeniem sygnalizatora (dla toru właściwego i niewłaściwego) - cz. 3c

Tarcza ostrzegawcza przejazdowa PKP, skala 1:25

1cm

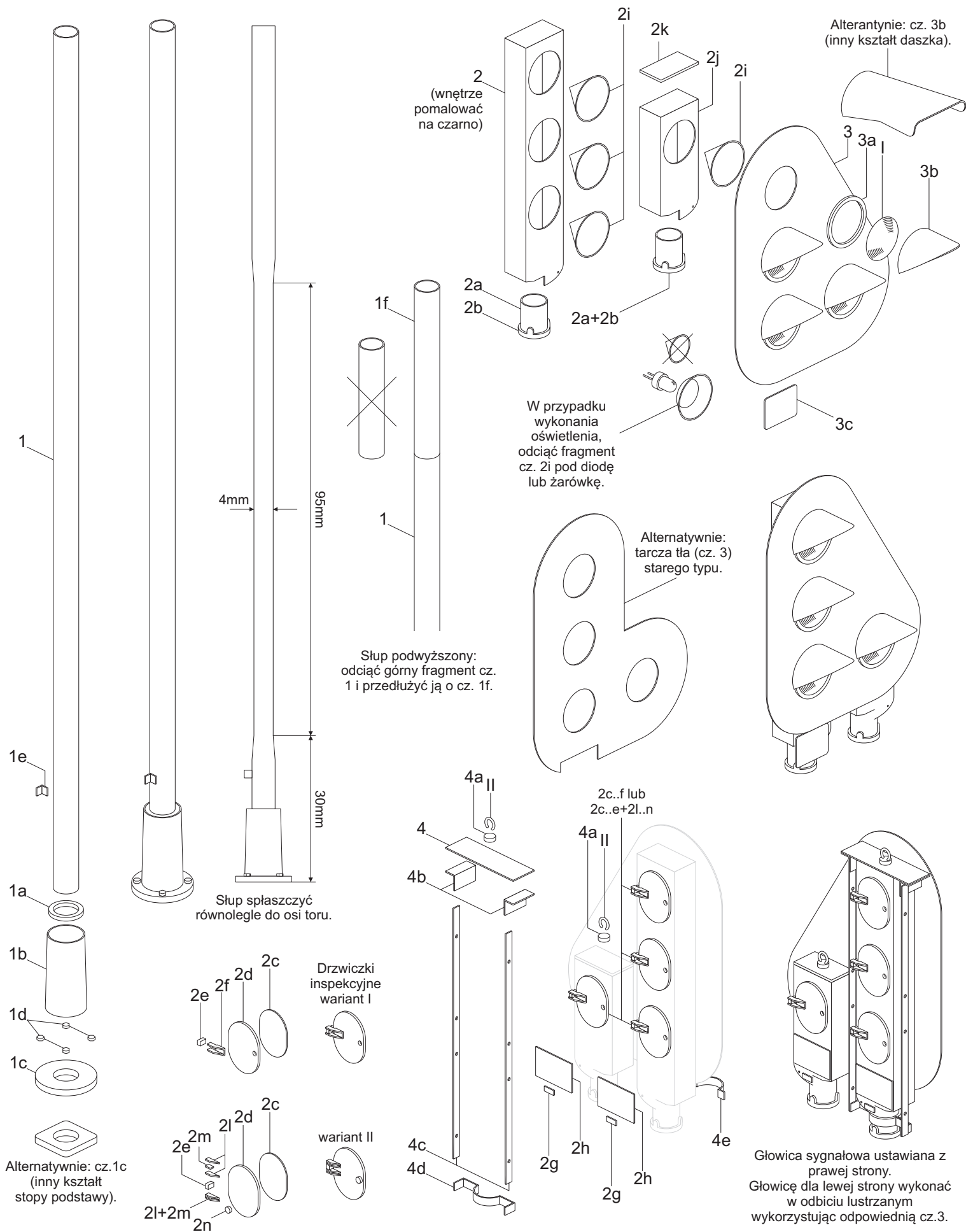

Tarcza ostrzegawcza przejazdowa PKP, skala 1:25

Instrukcja sklejania 1/4

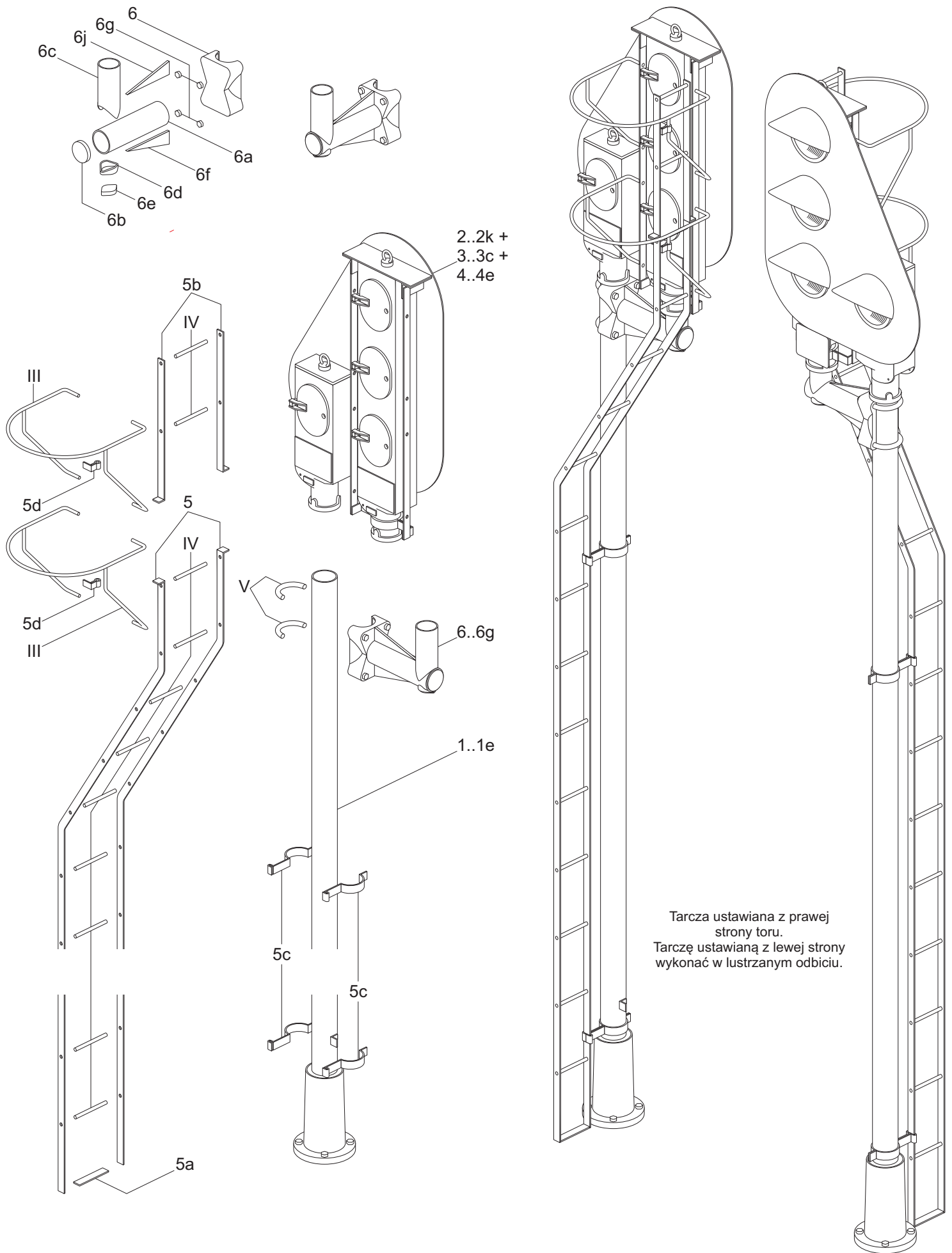

Tarcza ostrzegawcza przejazdowa PKP, skala 1:25

Instrukcja sklejania 2/4

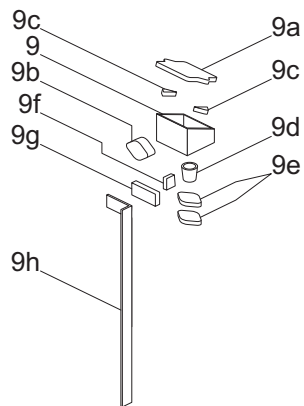

Puszka rozdzielcza

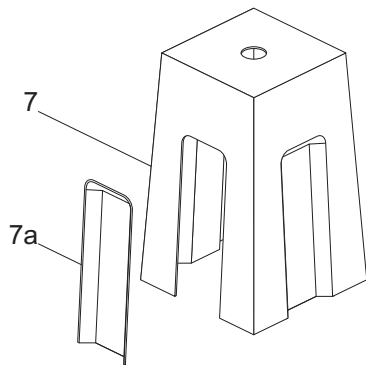

Fundament betonowy

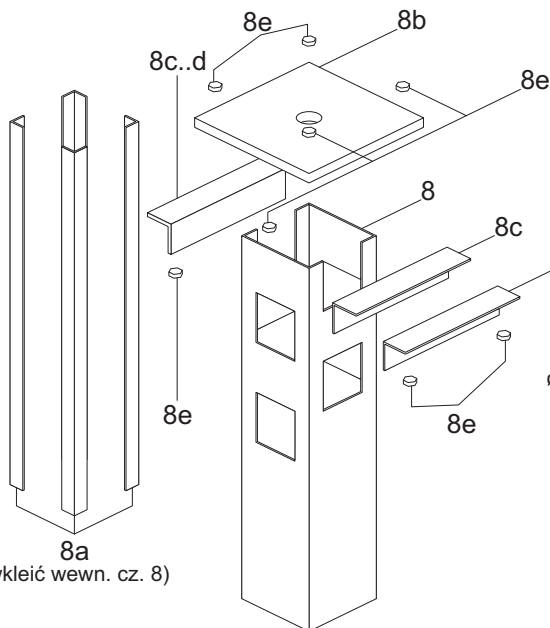
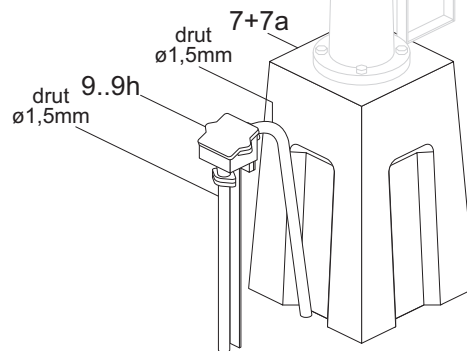

Fundament metalowy

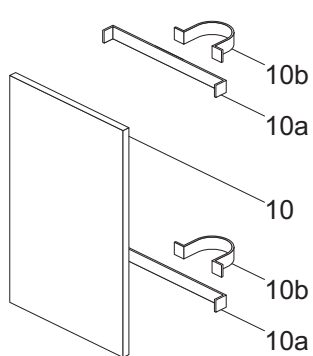
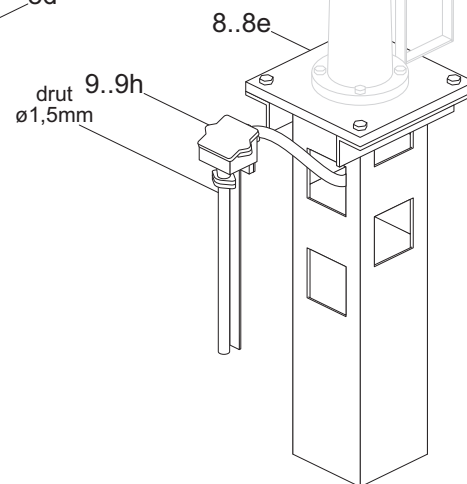

Wskaźnik W1 mały

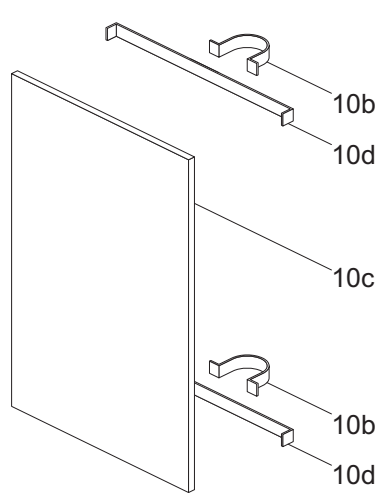
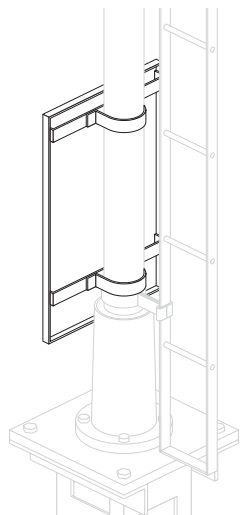

Wskaźnik W1 duży
(stosowany przy ograniczonej widoczności tarczy, o ile pozwala na to skrajnia)

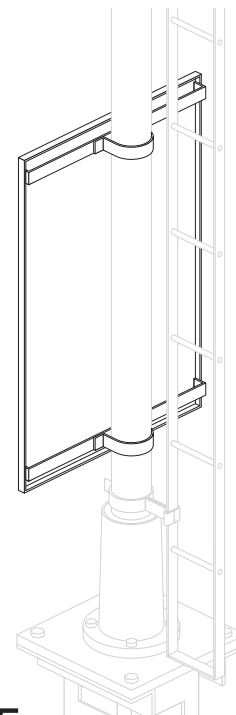

Tarcza ostrzegawcza przejazdowa PKP, skala 1:25

Instrukcja sklejania 3/4

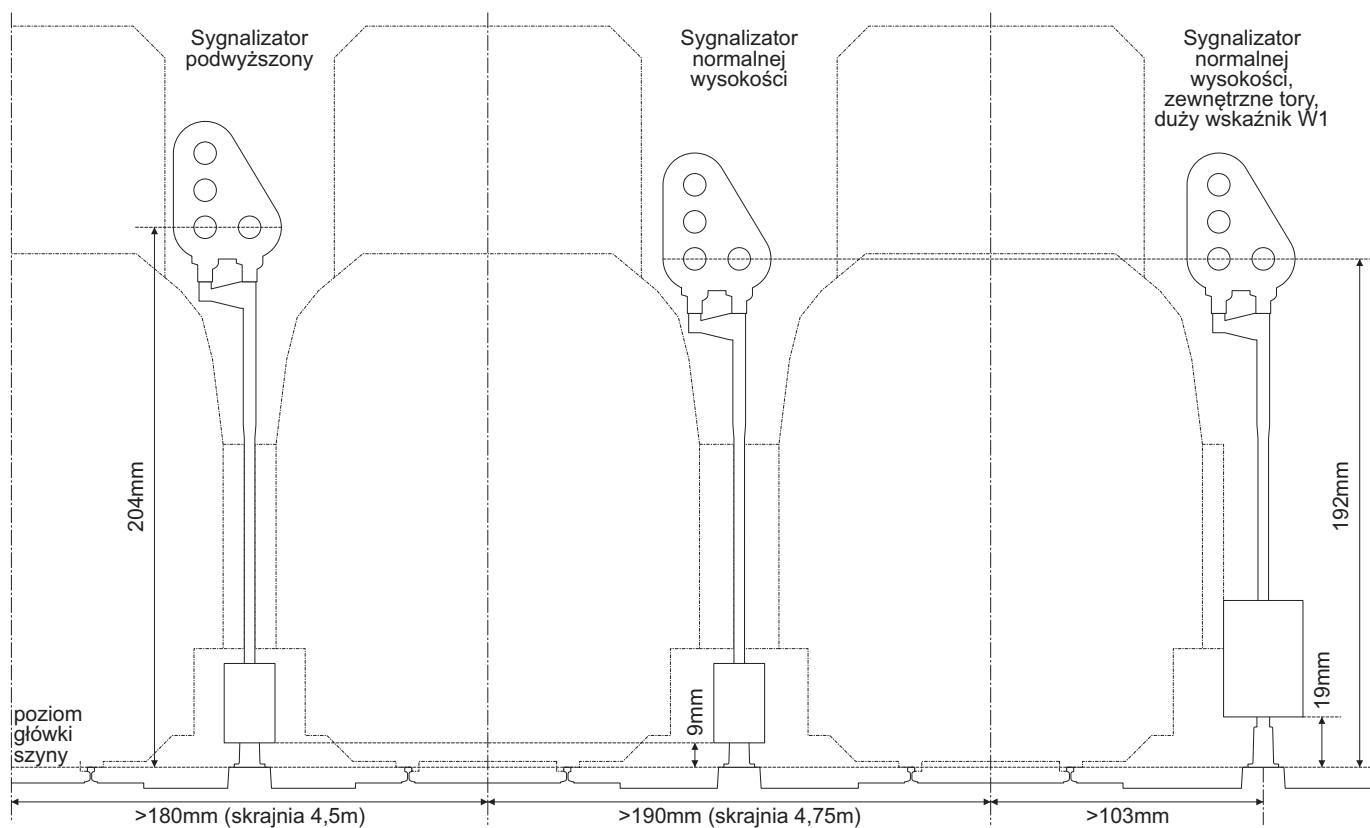

Ustawienie sygnalizatora względem skrajni (symetrycznie dla tarczy ustawianej po lewej stronie toru)

Układ barw świateł na tarczach

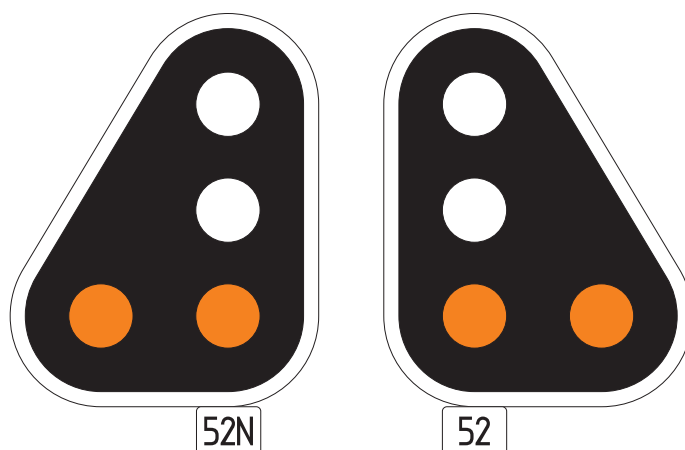

Kierunek przeciwny do zasadniczego (lewy tor)

Kierunek zasadniczy (prawy tor)

Tarcza ostrzegawcza przejazdowa PKP, skala 1:25

Instrukcja sklejania 4/4