

# Tarcza manewrowa PKP, skala 1:25

Szablony do samodzielnego wykonania elementów:

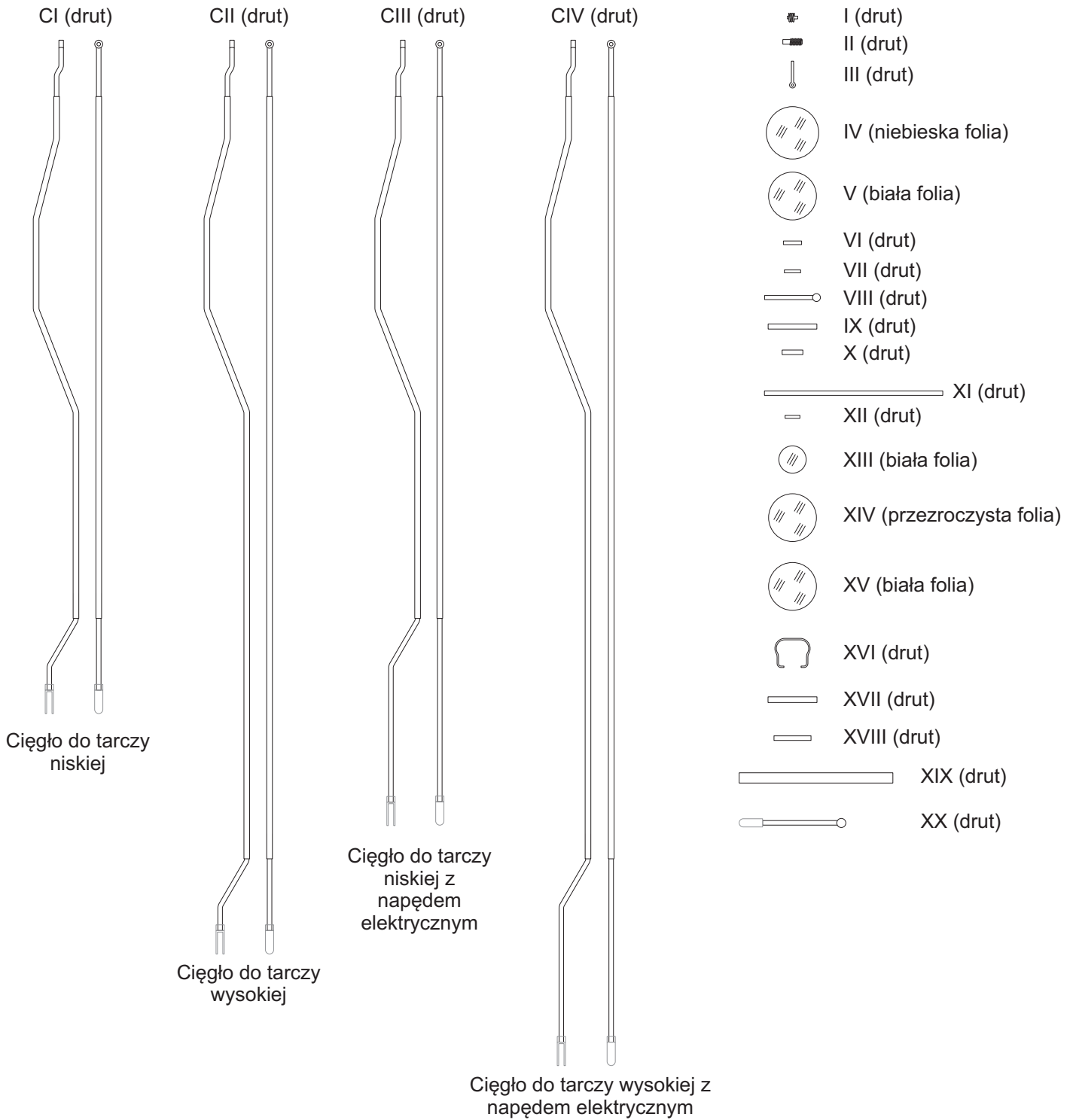

Tarcza manewrowa PKP, skala 1:25

1cm

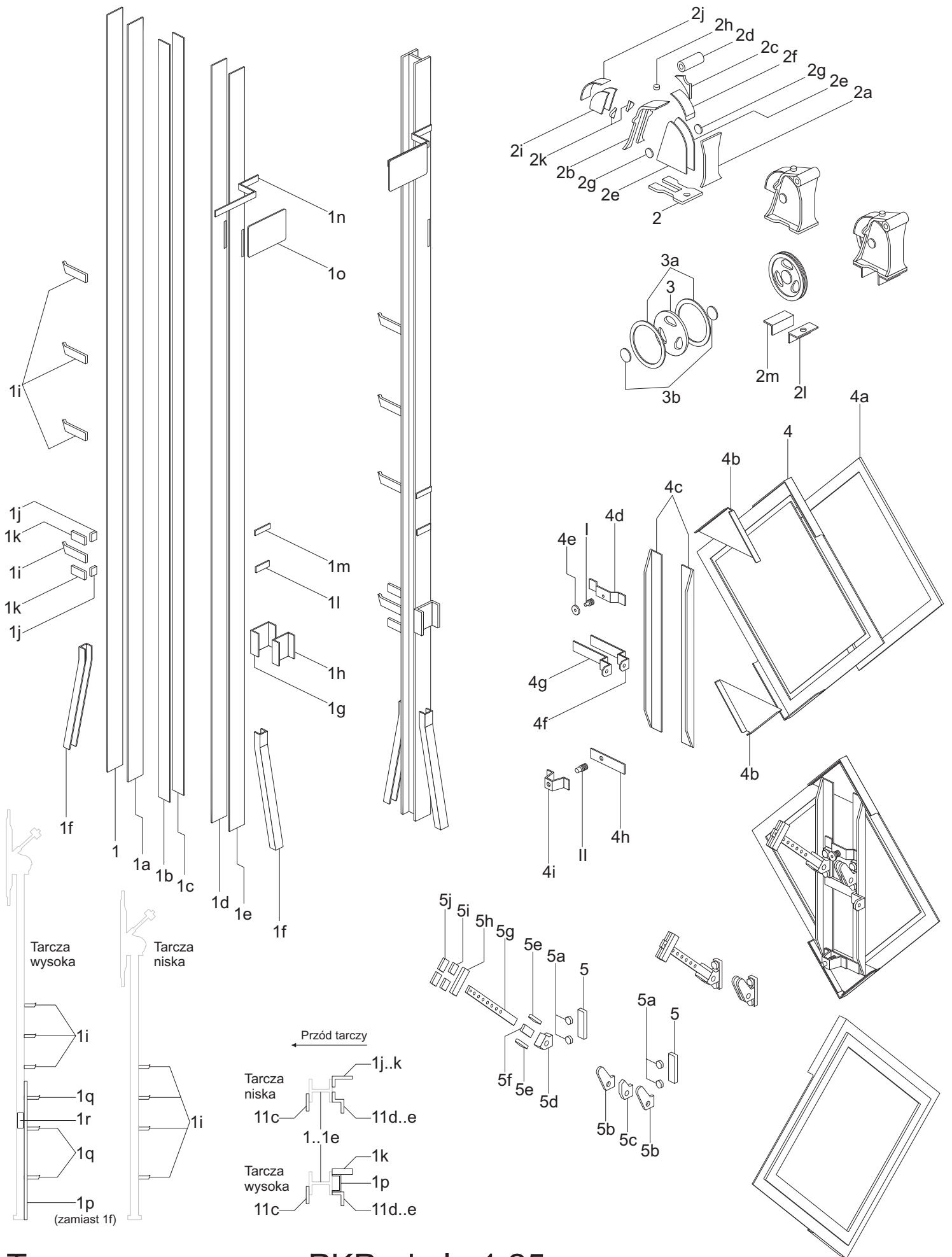

# Tarcza manewrowa PKP, skala 1:25

Instrukcja sklejania 1/4

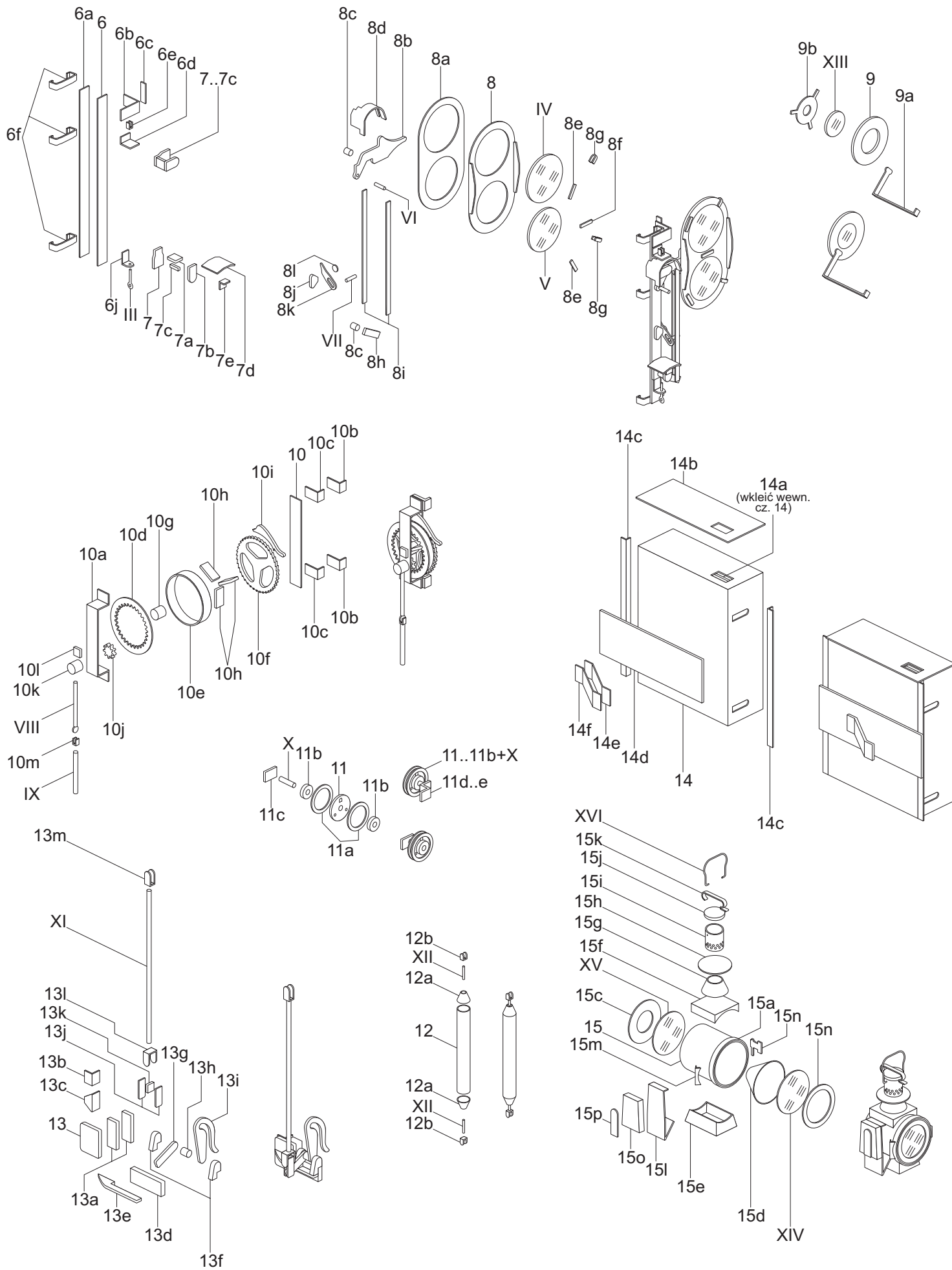

# Tarcza manewrowa PKP, skala 1:25

Instrukcja sklejania 2/4

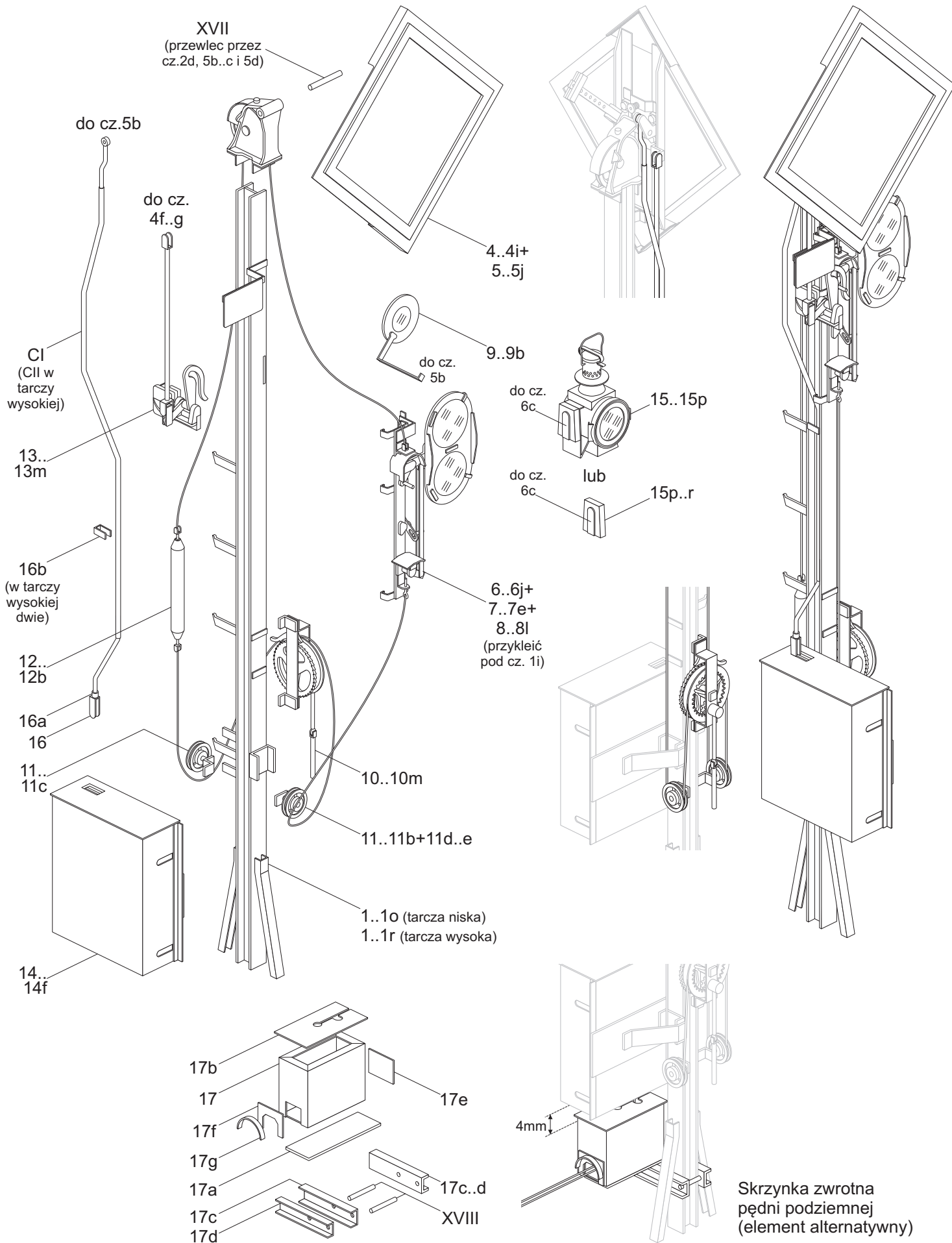

# Tarcza manewrowa PKP, skala 1:25

Instrukcja sklejania 3/4

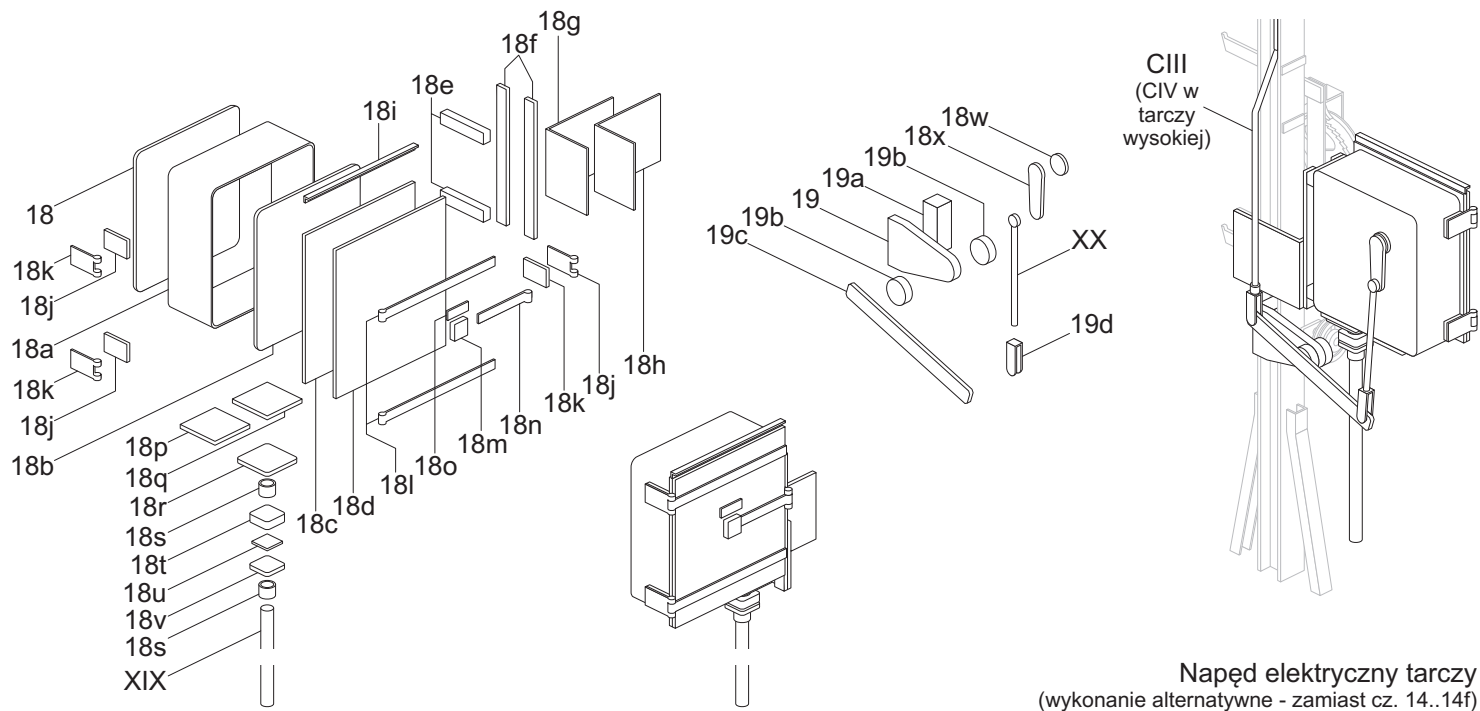

Umieszczenie tarczy względem skrajni

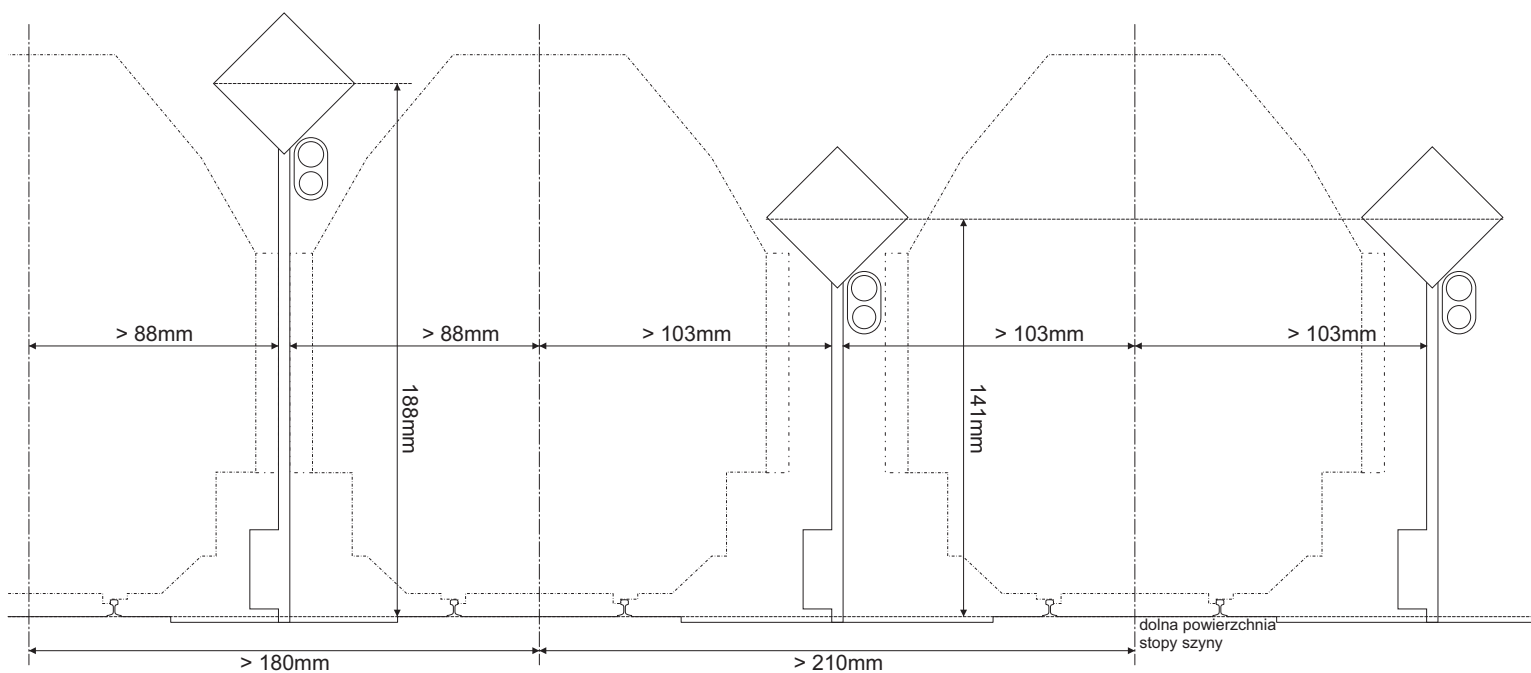

Tarcza manewrowa PKP, skala 1:25

Instrukcja sklejania 4/4