

Szablony

- I (przezroczysta folia lub żywica)
- II (druć)
- III (druć)
- IV (druć)
- V (przezroczysta folia lub żywica)

Puszki rozdzielcze

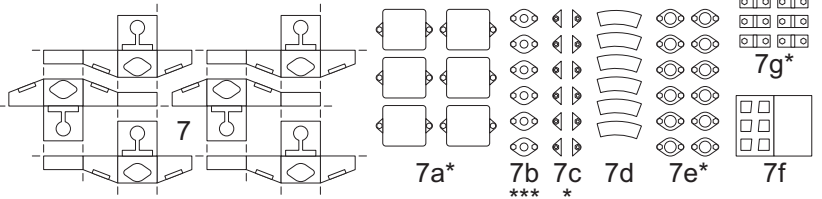

Historyczne sygnalizatory świetlne karzełkowe PKP

skala 1:25

Opracował Paweł Adamowicz (<http://pkprepo.net/>), 2016, niektóre prawa zastrzeżone

1cm

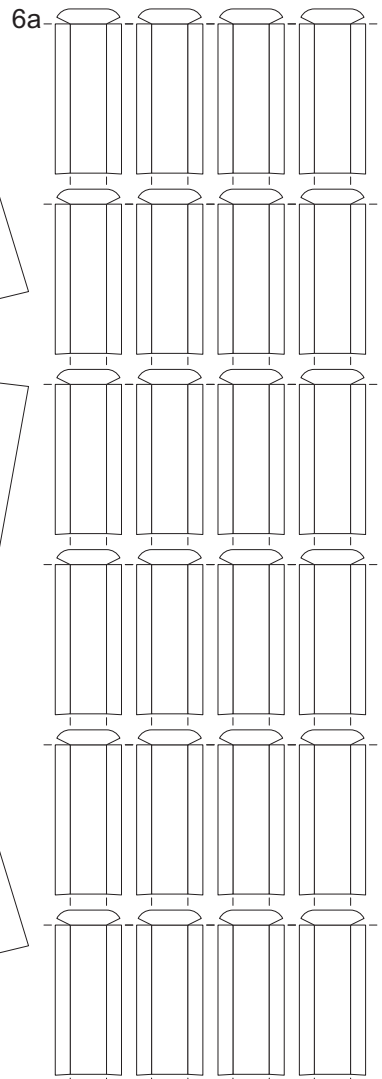
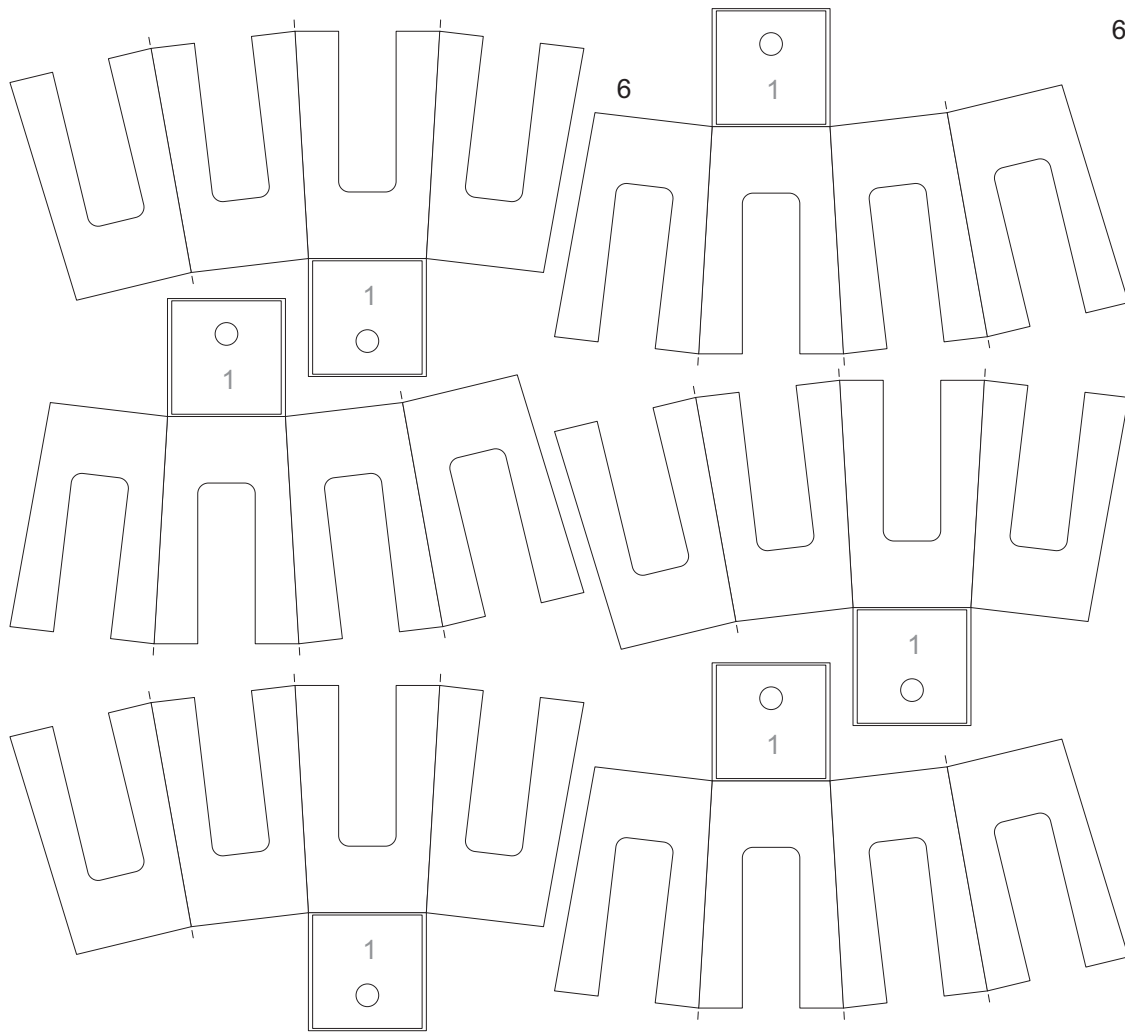

A	B	C	D	E	F	G	H	I	J	K	L	M	N	O	P	R	S	T
U	V	W	X	Y	Z	A ^{1/2}	B ^{1/2}	C ^{1/2}	D ^{1/2}	E ^{1/2}	F ^{1/2}	G ^{1/2}	H ^{1/2}	I ^{1/2}	J ^{1/2}	K ^{1/2}	L ^{1/2}	M ^{1/2}
N ^{1/2}	O ^{1/2}	P ^{1/2}	R ^{1/2}	S ^{1/2}	T ^{1/2}	U ^{1/2}	V ^{1/2}	W ^{1/2}	X ^{1/2}	Y ^{1/2}	Z ^{1/2}	A ²	B ²	C ²	D ²	E ²	F ²	G ²
H ²	I ²	J ²	K ²	L ²	M ²	N ²	O ²	P ²	R ²	S ²	T ²	U ²	V ²	W ²	X ²	Y ²	Z ²	W3A
W3B	W3C	W3D	W3E	W3F	W3G	W3H	W3I	W3J	W3K	W3L	W3M	W3N	W3O	W3P	W3R	W3S	W3T	W3U
W3V	W3W	W3A	W3A	W3Z	Sz1	Sz2	Sz3	Sz4	Sz5	Sz6	Sz7	Sz8	Sz9	Sz10	Sz11	Sz12	Sz13	Sz14
Sz15	Sz16	Sz17	Sz18	Sz19	Sz20	Sz21	Sz22	Sz23	Sz24	Sz25	Sz1n	Sz2n	Sz3n	Sz4n	Sz5n	Sz6n	Sz7n	Sz8n
Sz9n	Sz10n	Sz11n	Sz12n	Sz13n	Sz14n	Sz15n	Sz16n	Sz17n	Sz18n	Sz19n	Sz20n	Sz21n	Sz22n	Sz23n	Sz24n	Sz25n	Tm1	Tm2
Tm3	Tm4	Tm5	Tm6	Tm7	Tm8	Tm9	Tm10	Tm11	Tm12	Tm13	Tm14	Tm15	Tm16	Tm17	Tm18	Tm19	Tm20	Tm21
Tm22	Tm23	Tm24	Tm25	Tm26	Tm27	Tm28	Tm29	Tm30	Tm31	Tm32	Tm33	Tm34	Tm35	Tm36	Tm37	Tm38	Tm39	Tm40
Tm41	Tm42	Tm43	Tm44	Tm45	Tm46	Tm47	Tm48	Tm49	Tm50	Tz1	Tz2	Tz3	Tz4	Tz5	Tz6	Tz7	Tz8	Tz9
Tz10	Tz11	Tz12	Tz13	Tz14	Tz15	Tz16	Tz17	Tz18	Tz19	Tz20	Tz21	Tz22	Tz23	Tz24	Tz25	Tz26	Tz27	Tz28
Tz29	Tz30	Tz31	Tz32	Tz33	Tz34	Tz35	Tz36	Tz37	Tz38	Tz39	Tz40	Tz41	Tz42	Tz43	Tz44	Tz45	Tz46	Tz47
Tz48	Tz49	Tz50	m	m	m	m	m	m	m									

Tabliczki z oznaczeniem sygnalizatora (cz. 8)

1cm

Historyczne sygnalizatory świetlne karzełkowe PKP skala 1:25

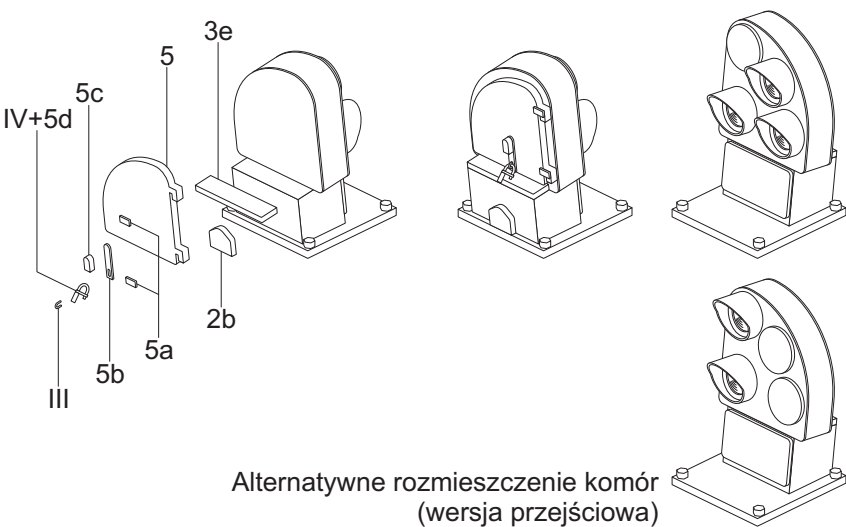
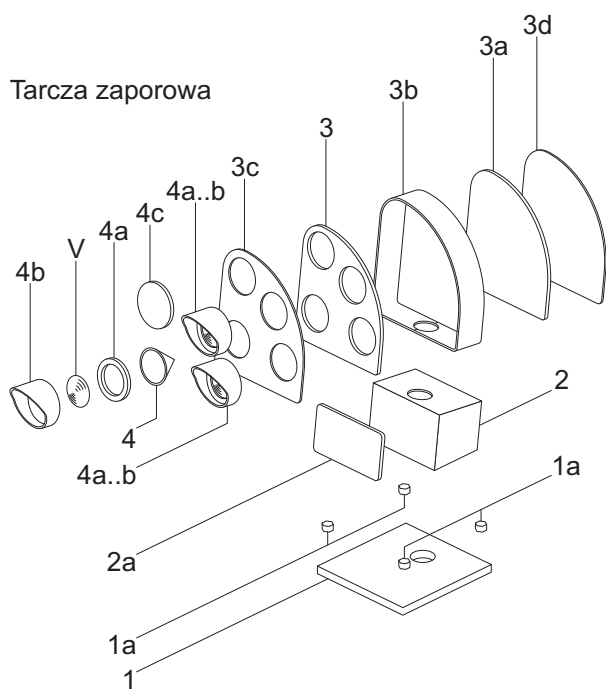
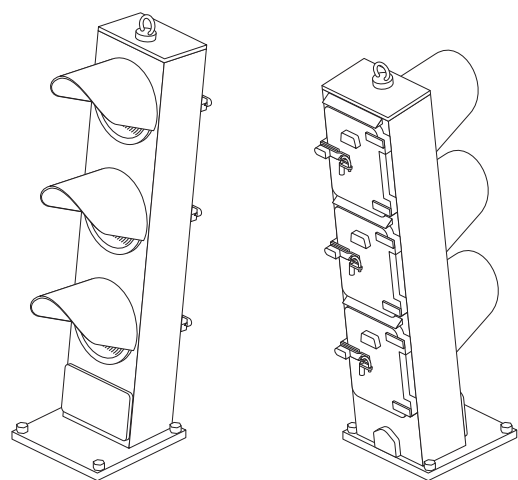
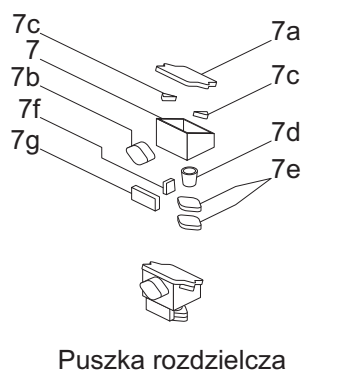
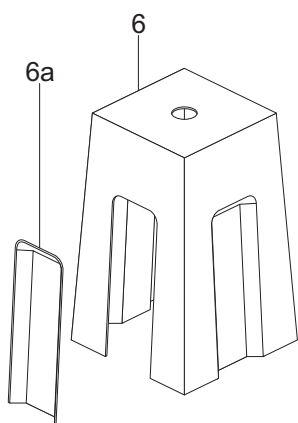
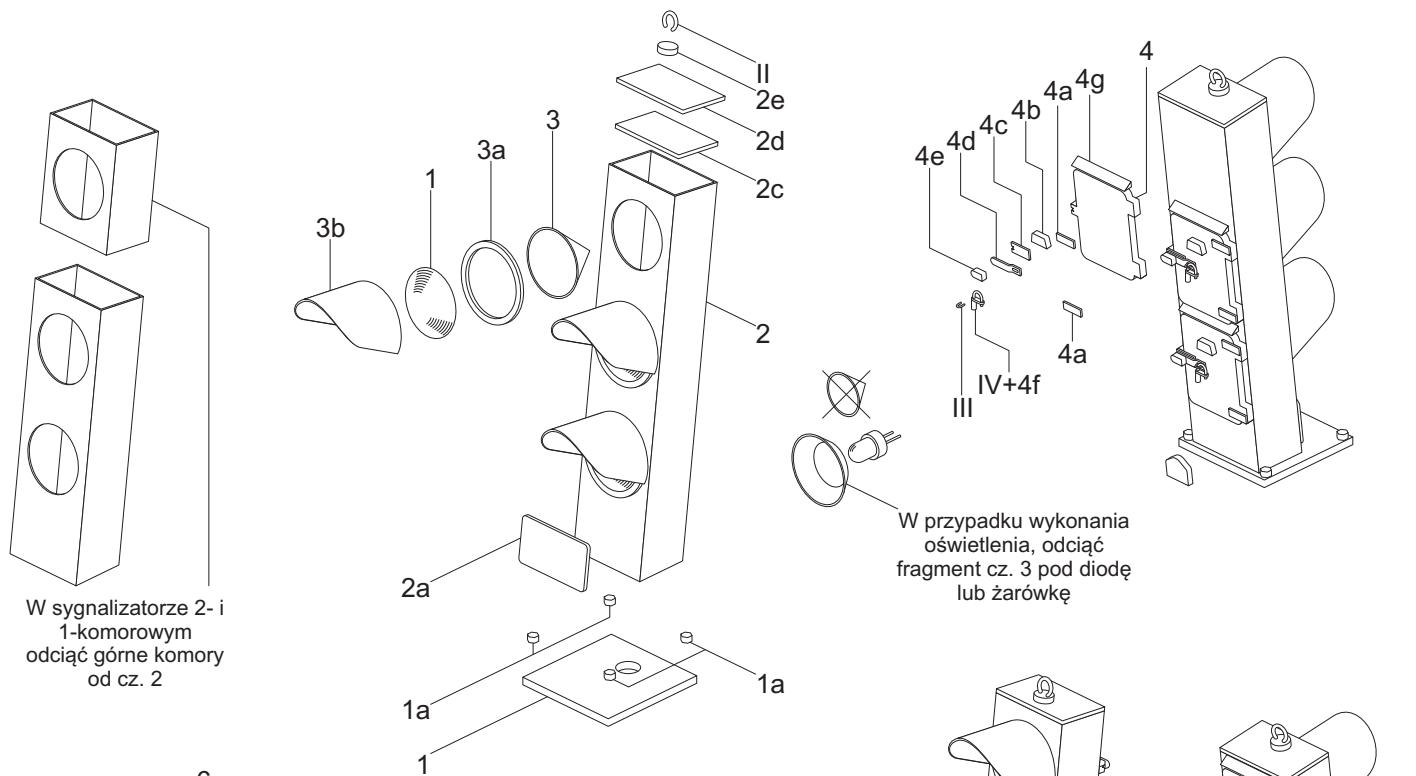

Historyczne sygnalizatory świetlne karzełkowe PKP, skala 1:25

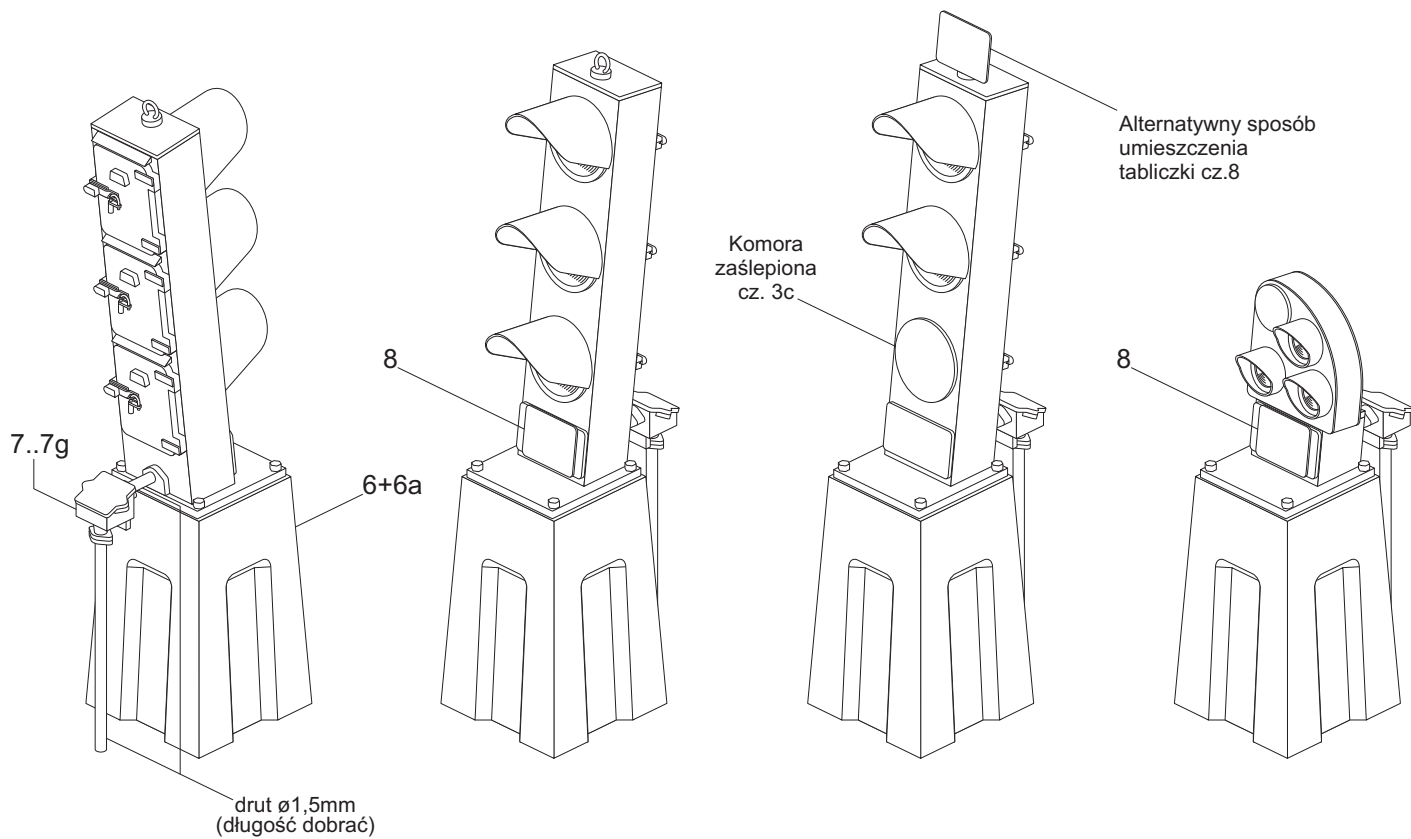

Przykłady barw świateł i malowania głowic sygnalizatorów karzełkowych

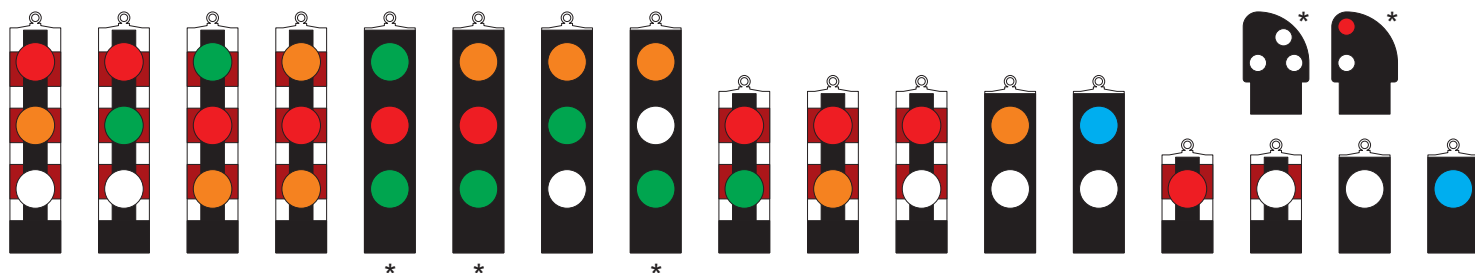

* Układ świateł stosowany do 1959 roku i w okresie przejściowym. Przed 1959 wszystkie sygnalizatory karzełkowe były malowane z przodu na czarno.

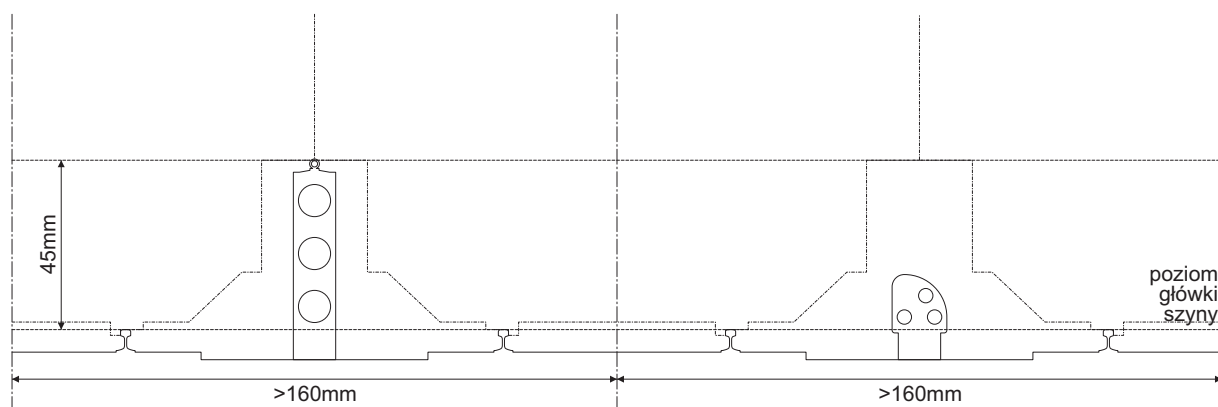

Ustawienie sygnalizatora względem skrajni

Historyczne sygnalizatory świetlne karzełkowe PKP, skala 1:25