

## Teile zum 3D-Druck

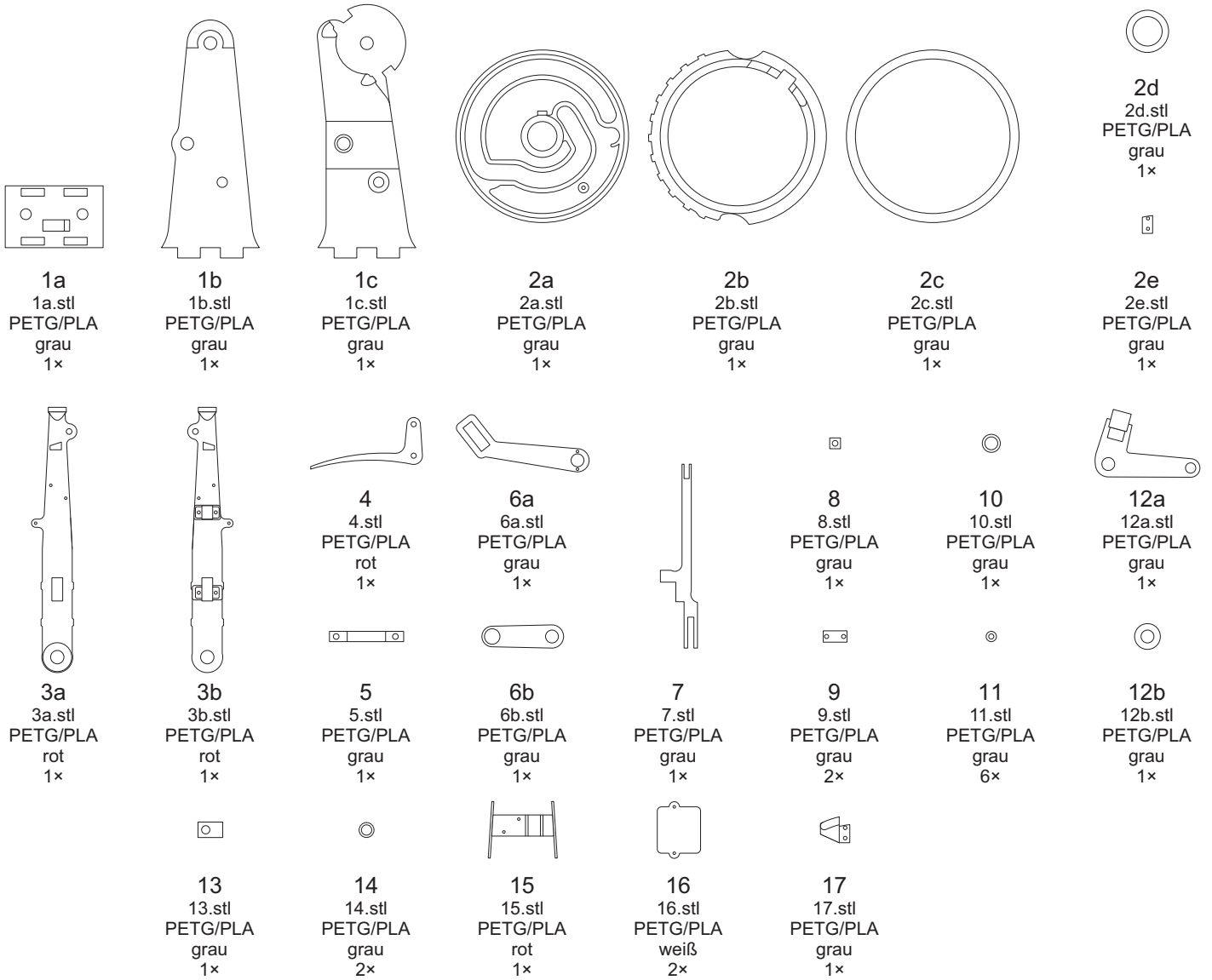

## Andere Teile

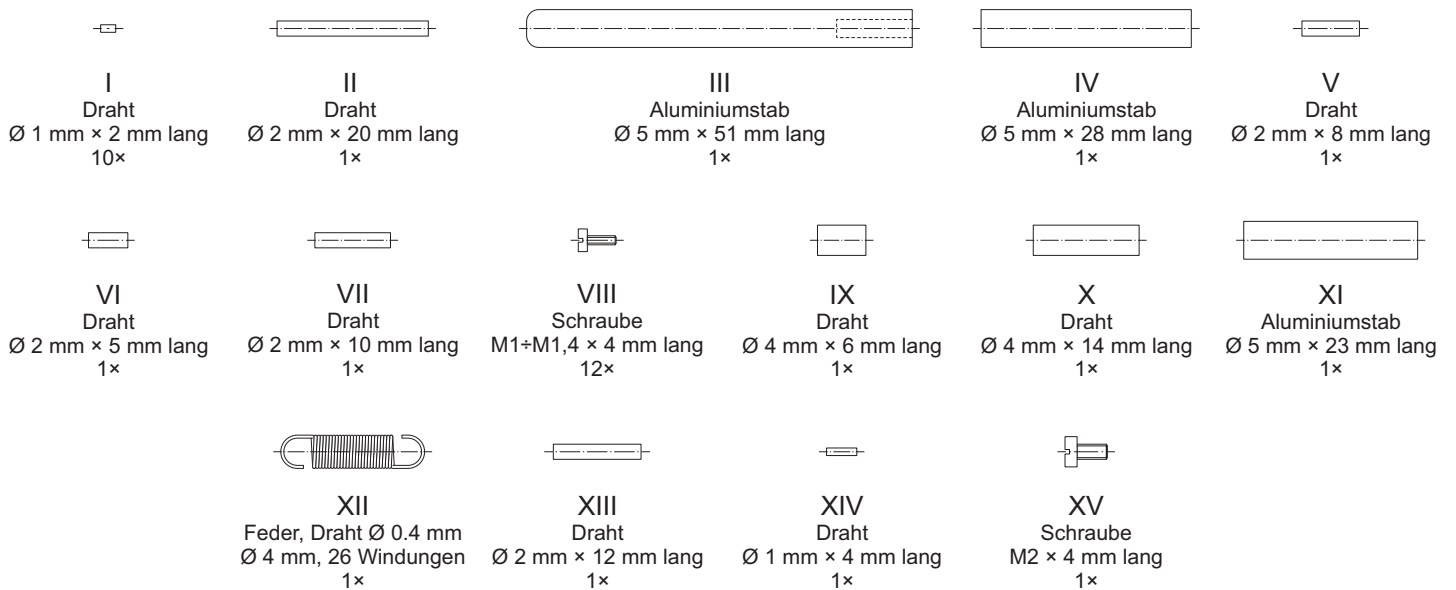

# Signalhebel, Maßstab 1:5

## Teileliste

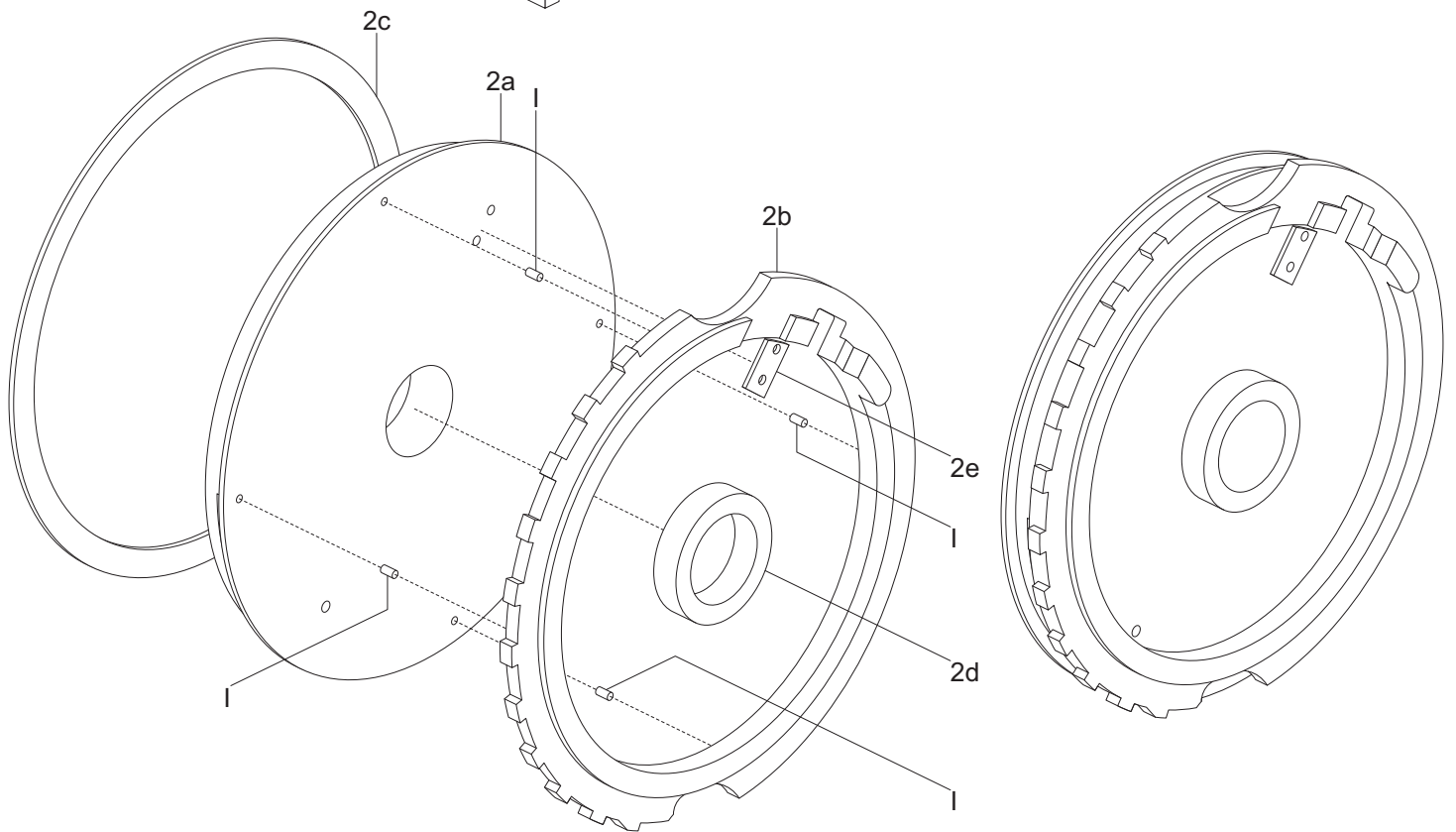
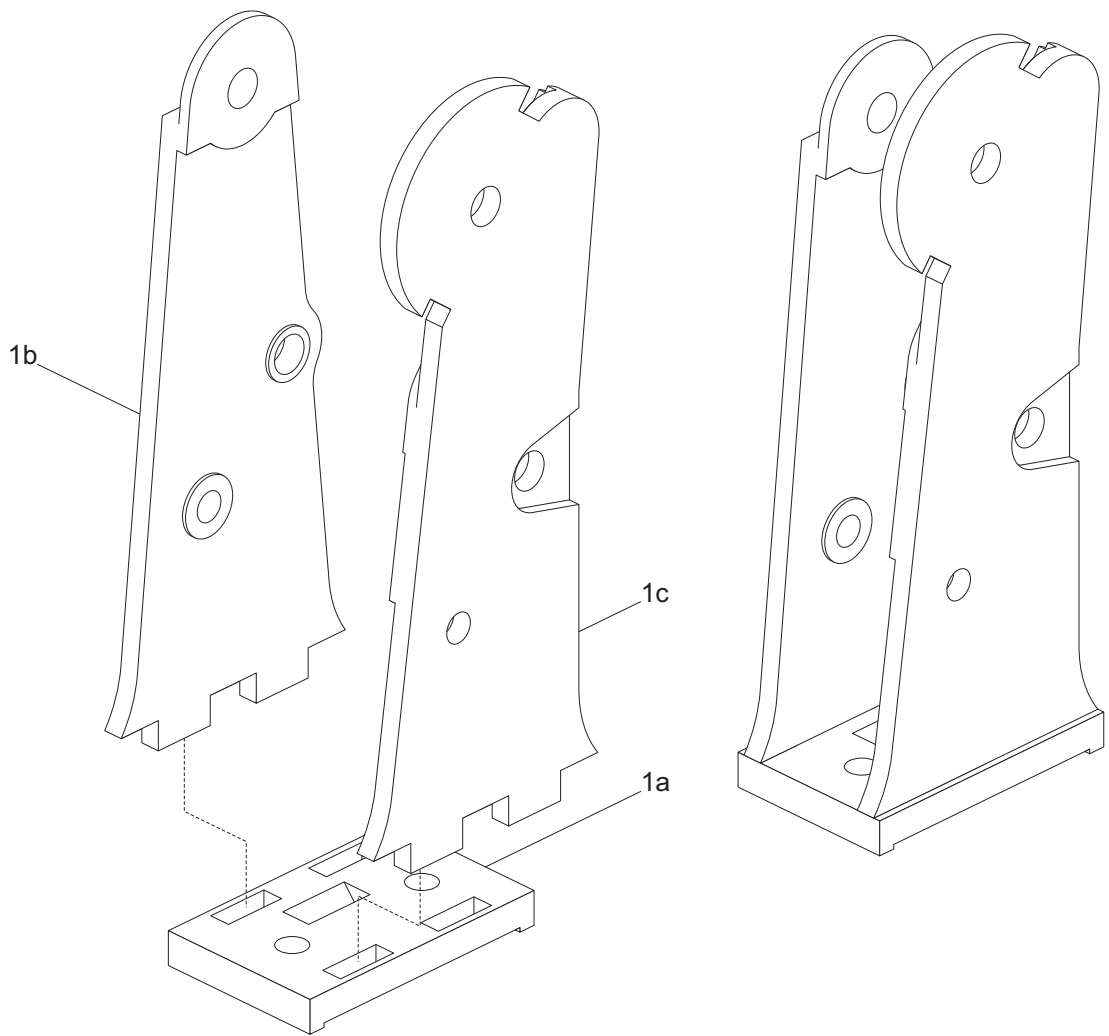

# Signalhebel, Maßstab 1:5

Bauanleitung 1/5

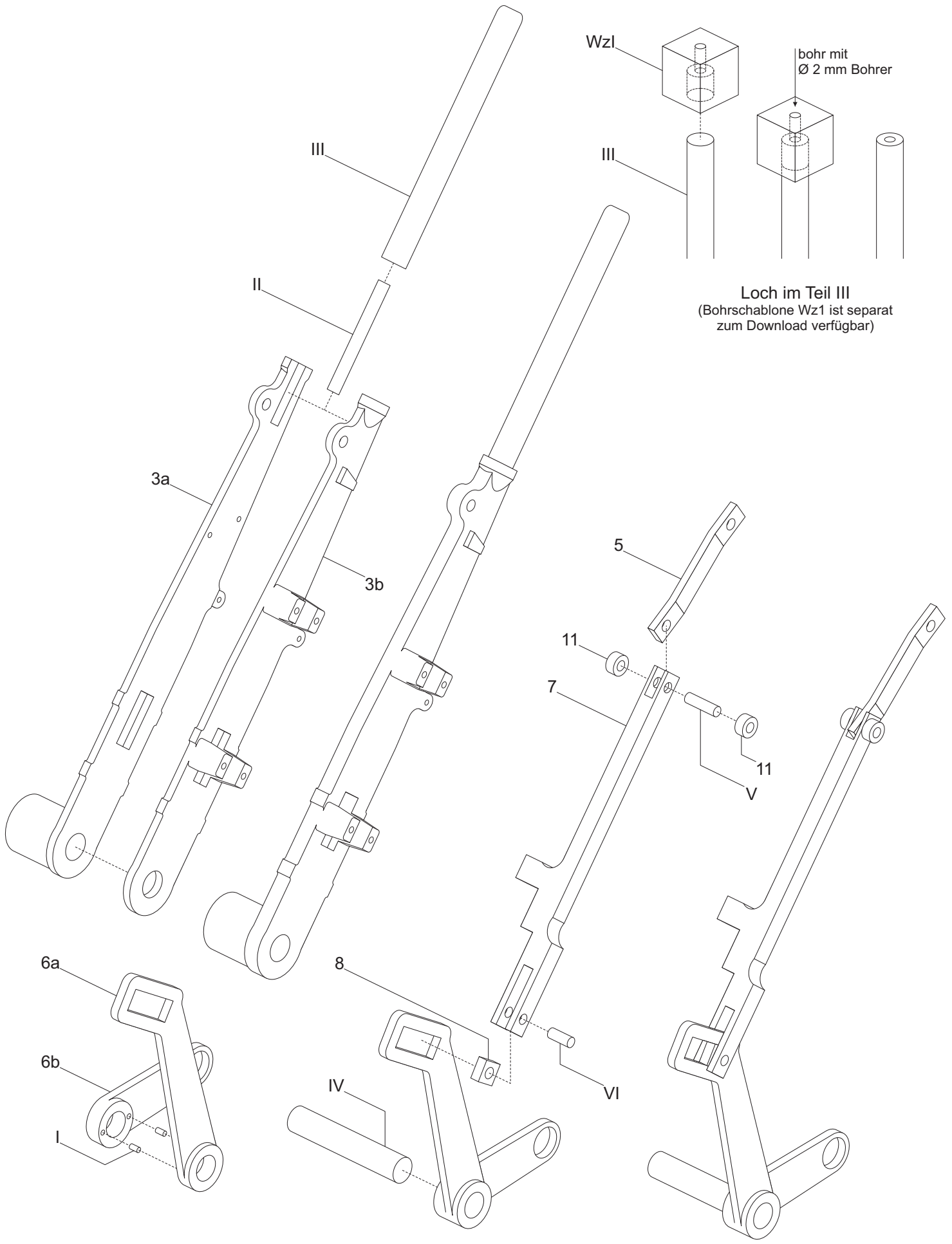

# Signalhebel, Maßstab 1:5

Bauanleitung 2/5



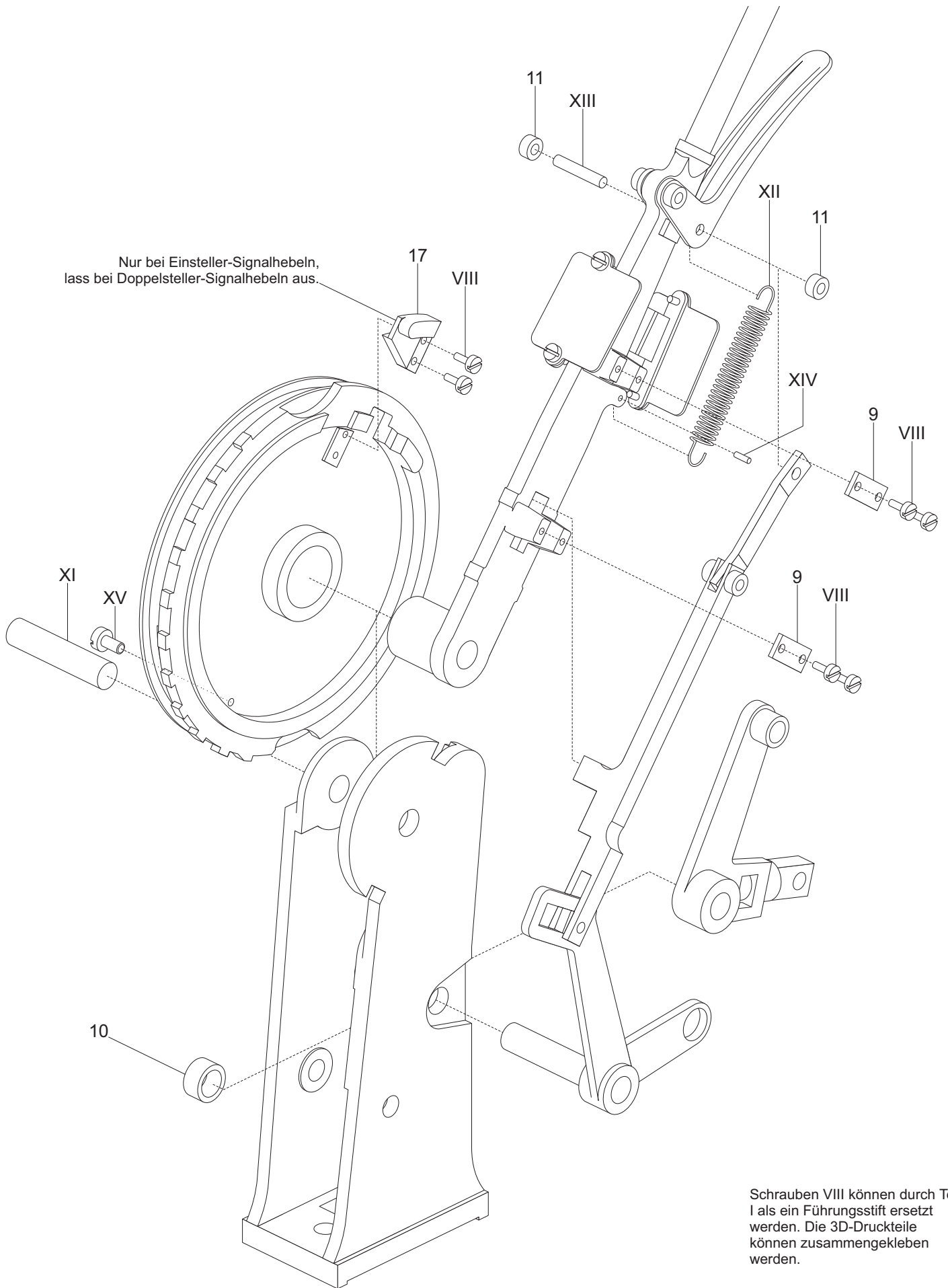

# Signalhebel, Maßstab 1:5

Bauanleitung 4/5

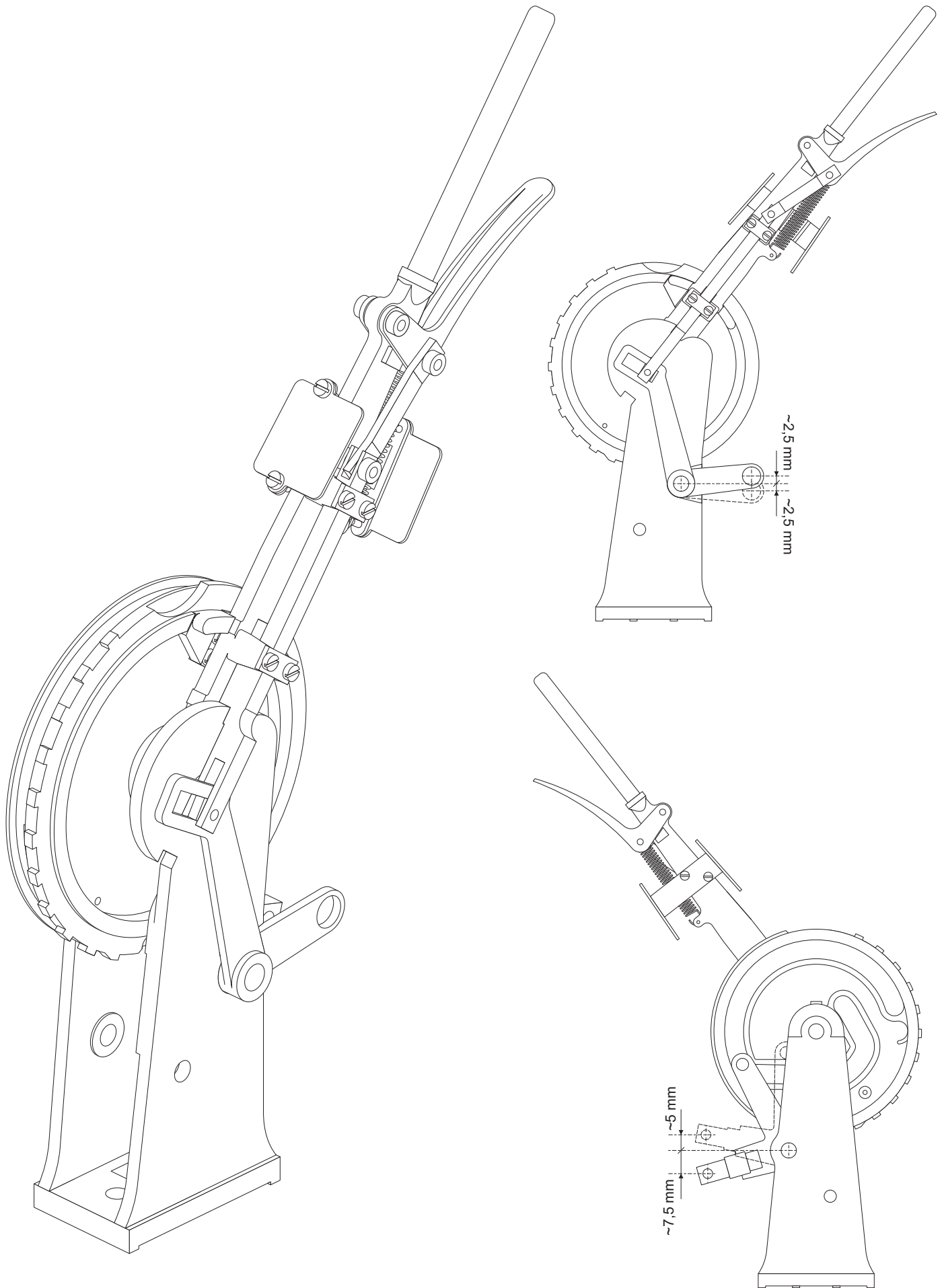

# Signalhebel, Maßstab 1:5

Bauanleitung 5/5