

# Railway signals and indicators DRG/DR, 1935-1945, scale 1:160 (N)

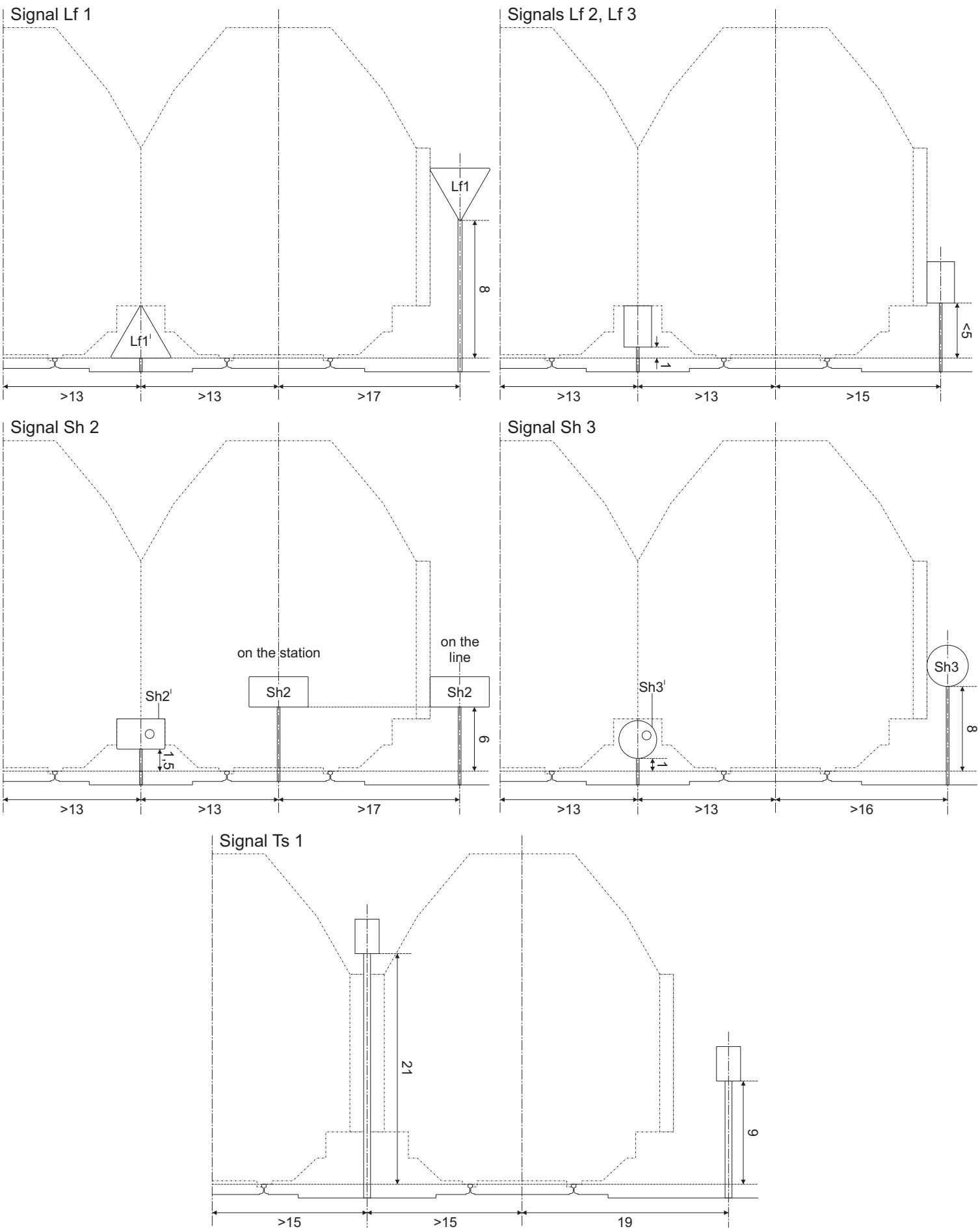

# Railway signals and indicators DRG/DR, 1935-1945, scale 1:160 (N)

Signals placement against the loading gauge 1/4

Indicators K 2, K 4

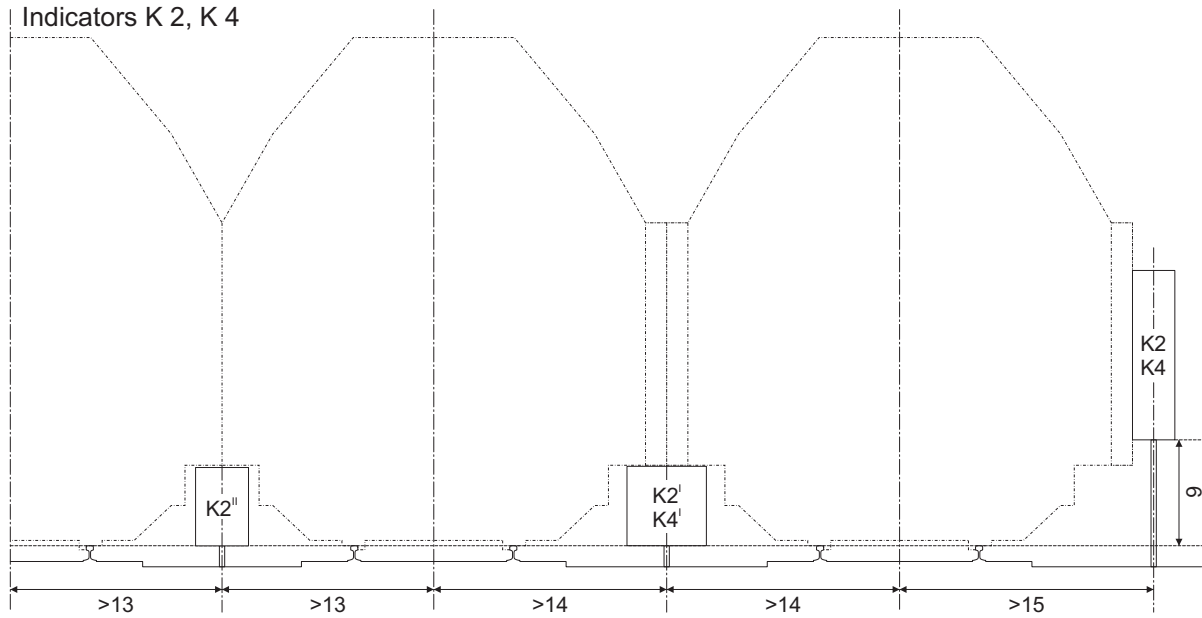

Indicators K 3o, K 3z

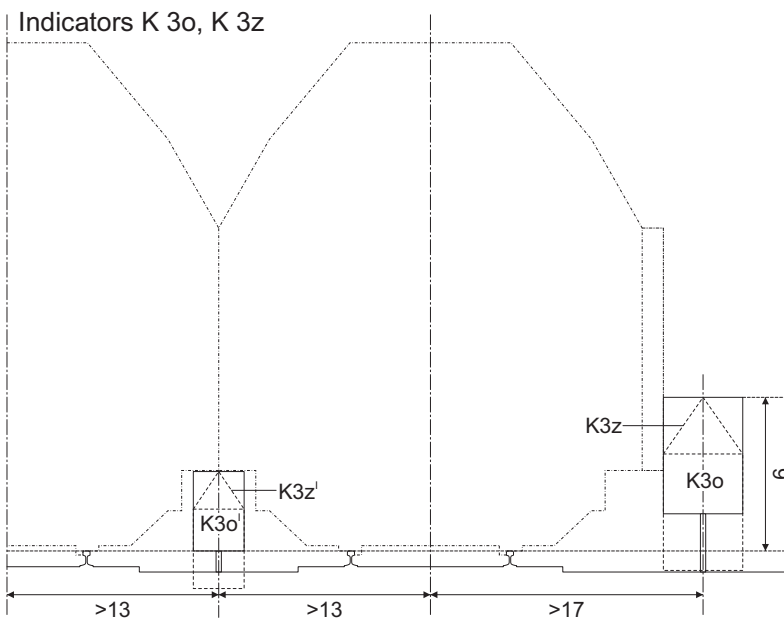

Indicator K 6

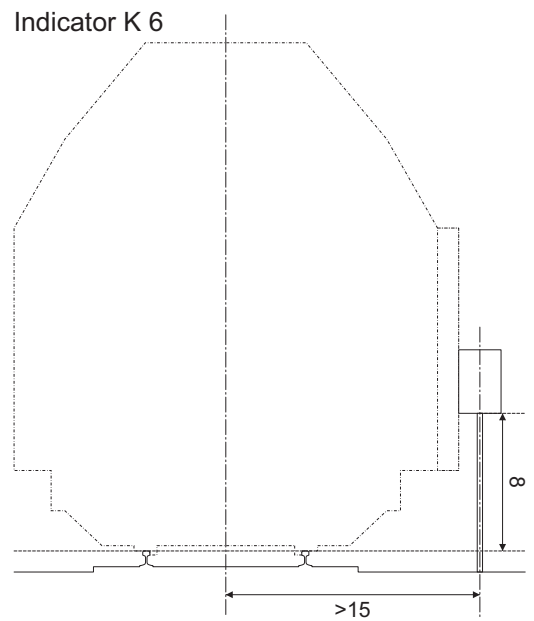

Indicator K 5

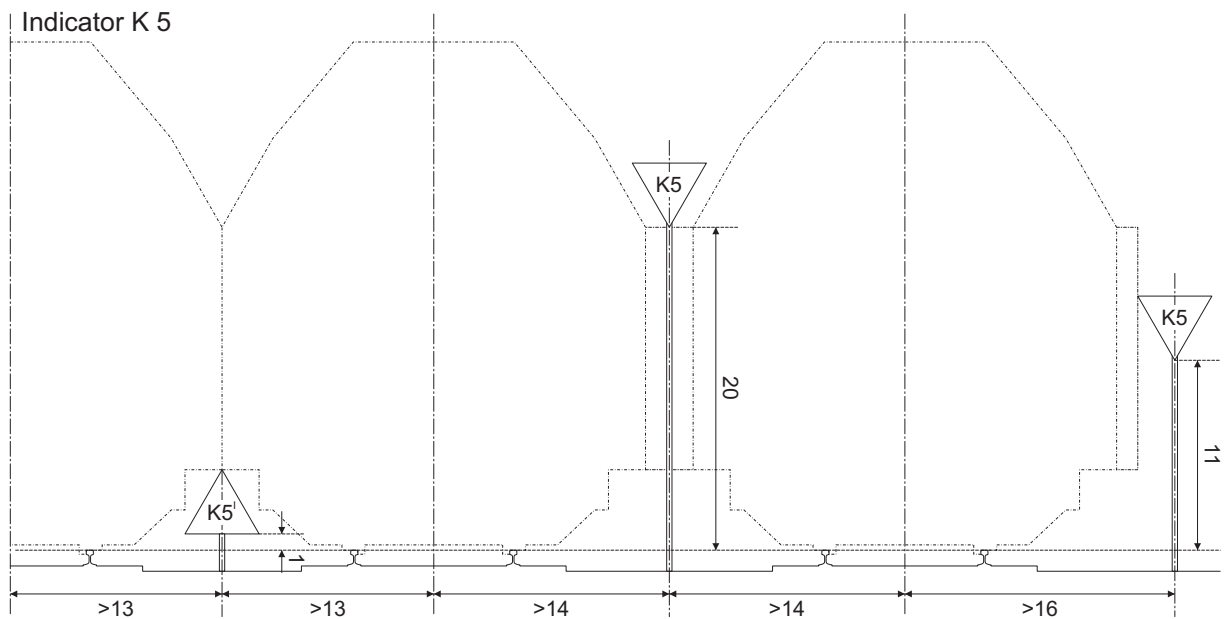

## Railway signals and indicators DRG/DR, 1935-1945, scale 1:160 (N)

Signals placement against the loading gauge 2/4

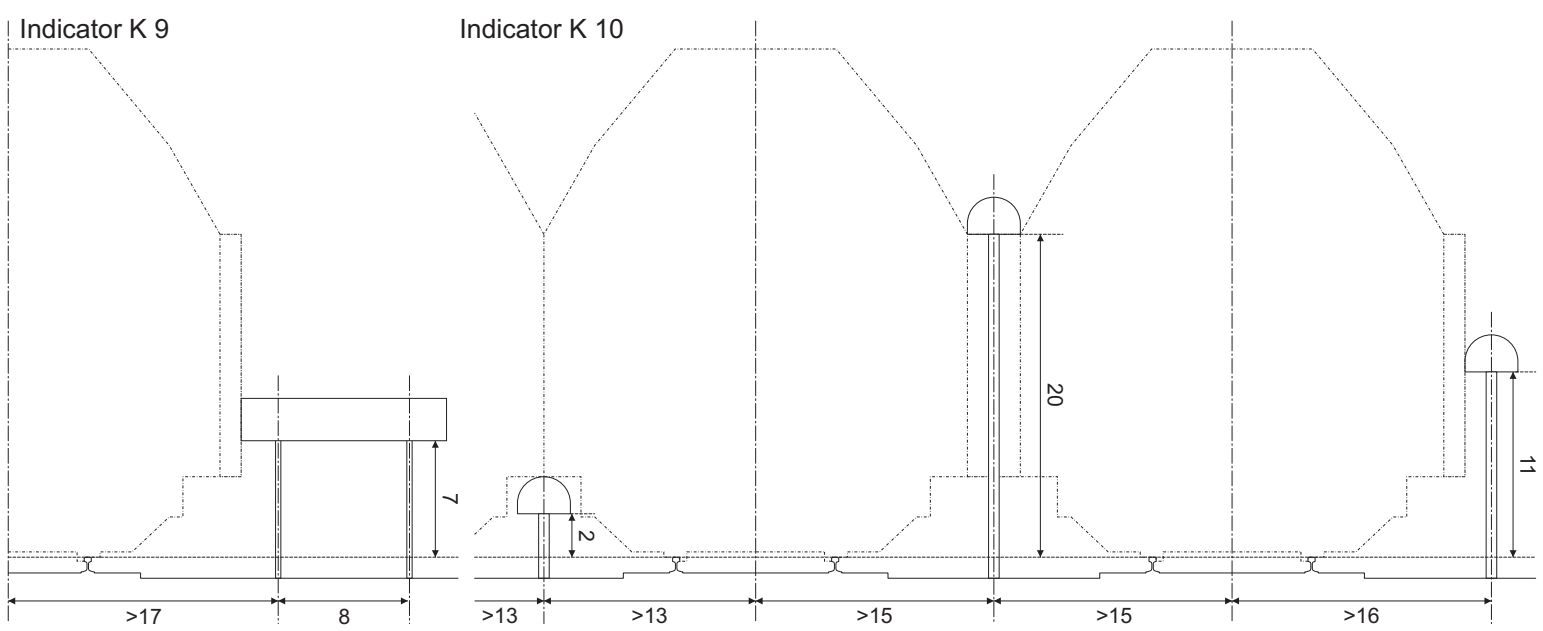
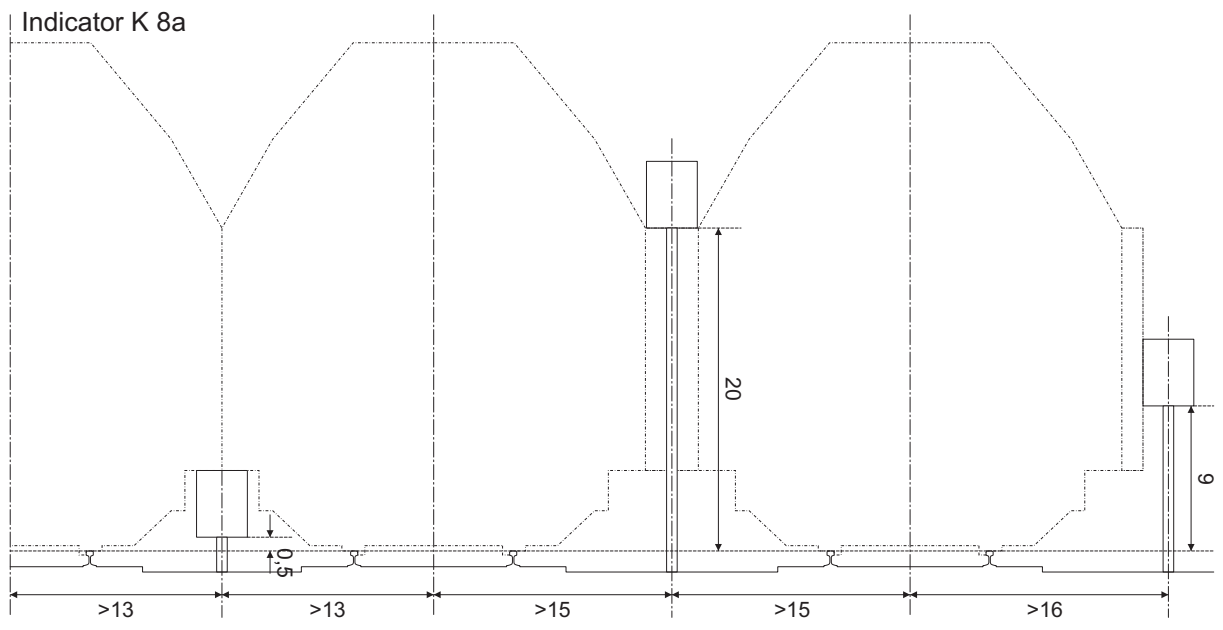
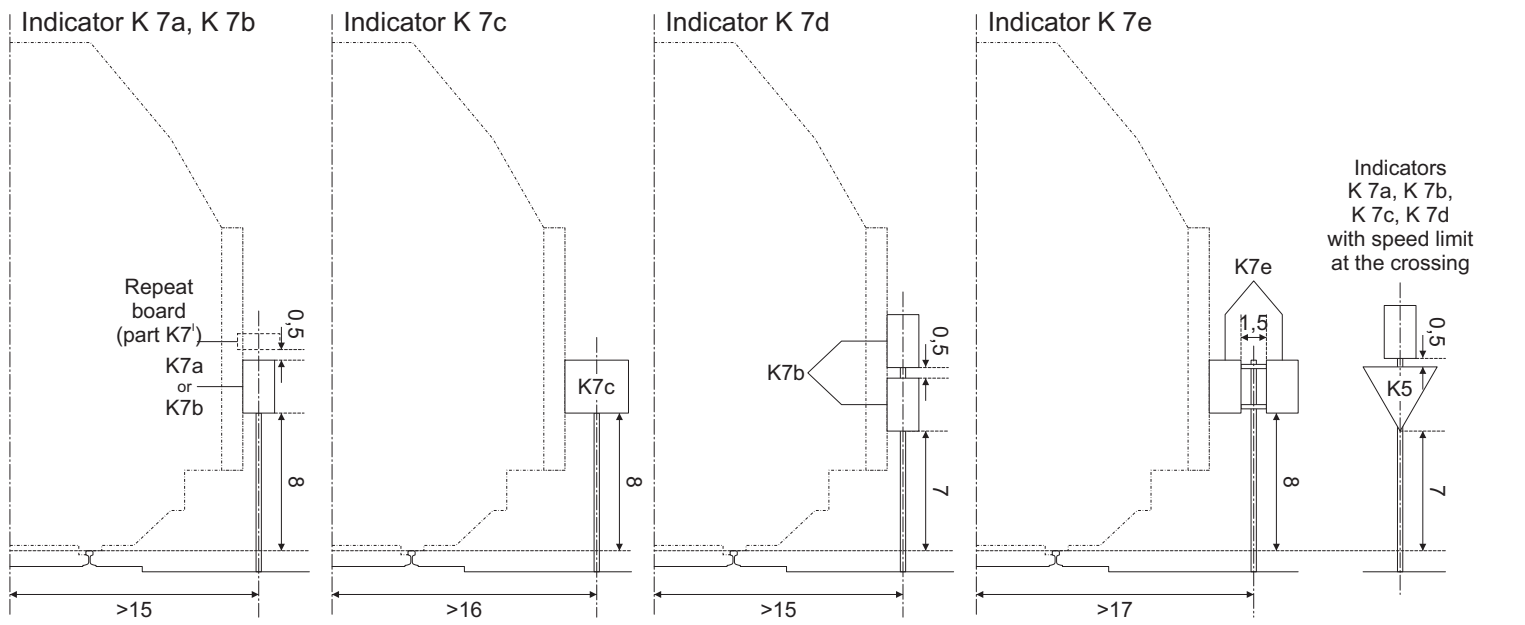

# Railway signals and indicators DRG/DR, 1935-1945, scale 1:160 (N)

Signals placement against the loading gauge 3/4

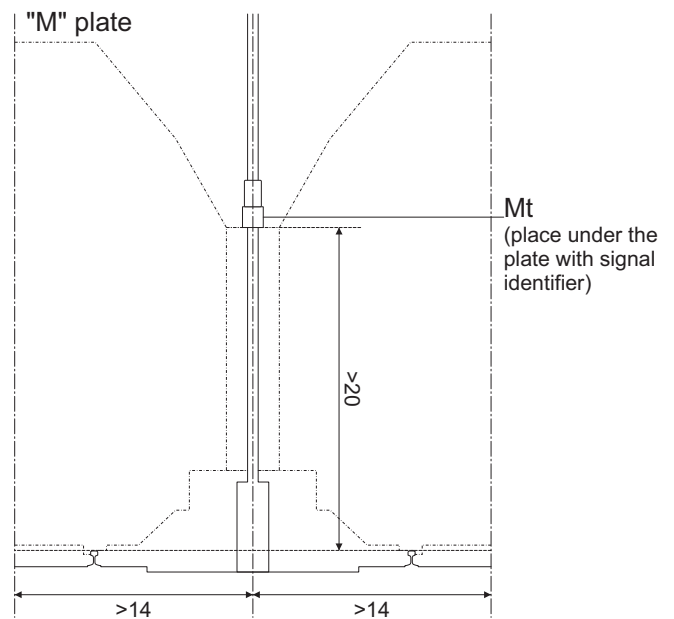
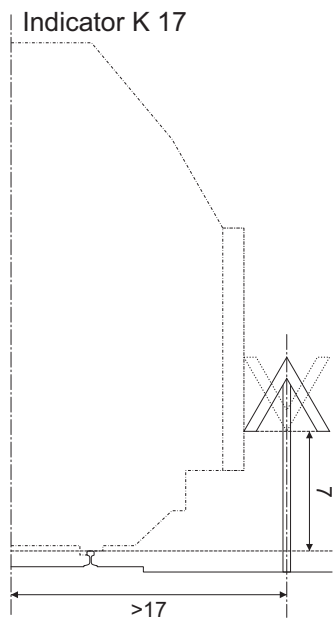
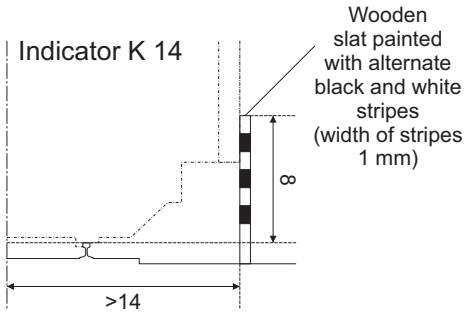
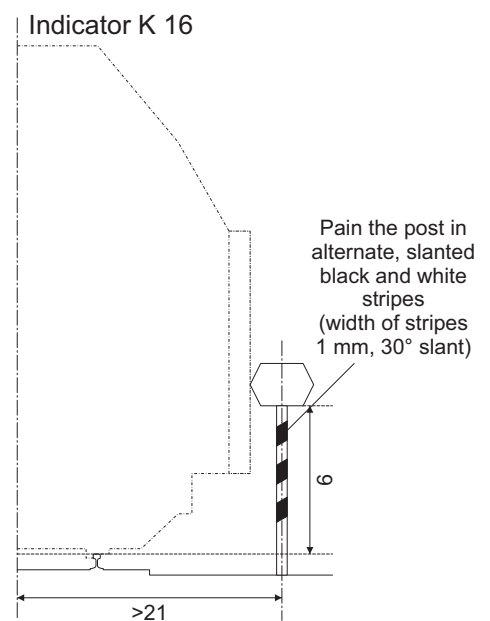
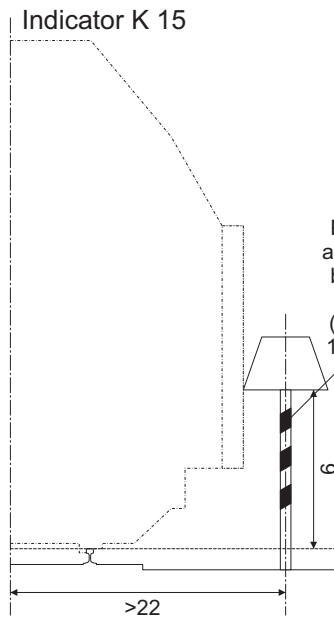
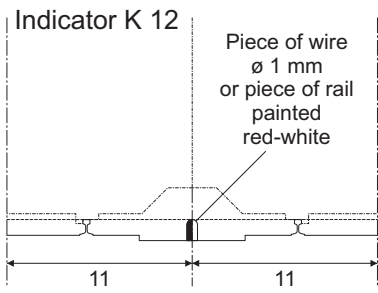

Signals for electrified rail lines EI 1-EI 6, K 8b

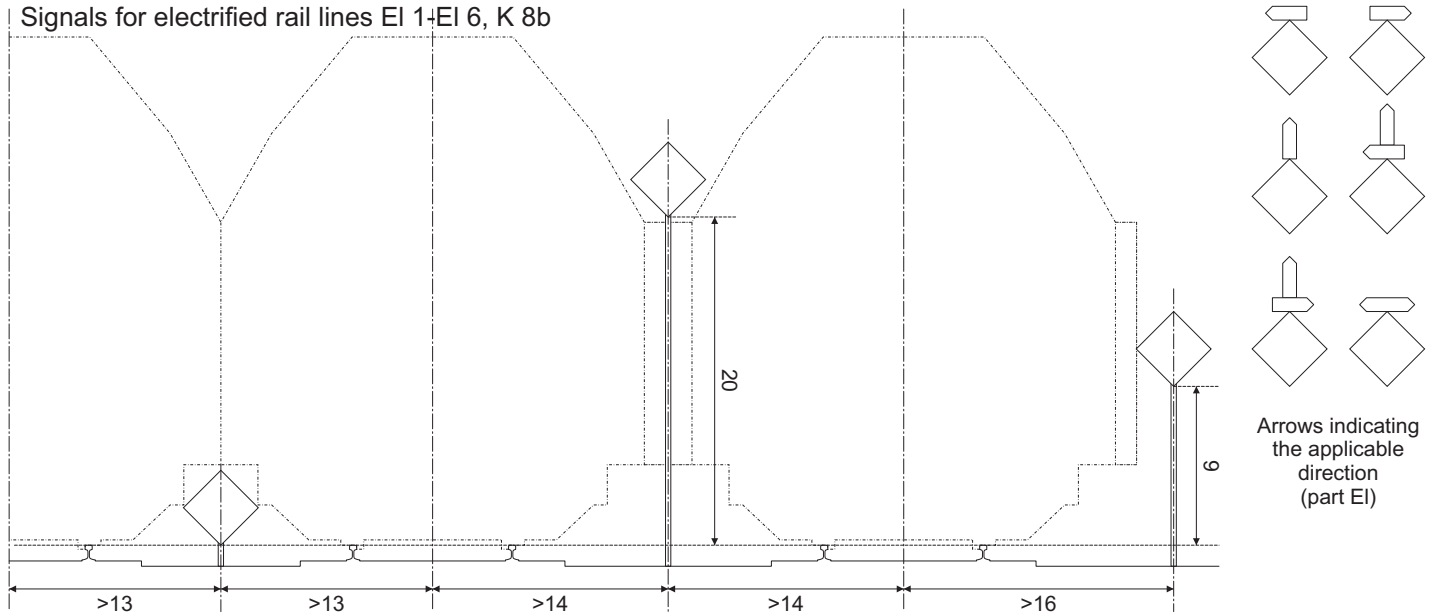

# Railway signals and indicators DRG/DR, 1935-1945, scale 1:160 (N)

Signals placement against the loading gauge 4/4