

Railway signals and indicators DRG/DR, 1935-1945, scale 1:120 (TT)

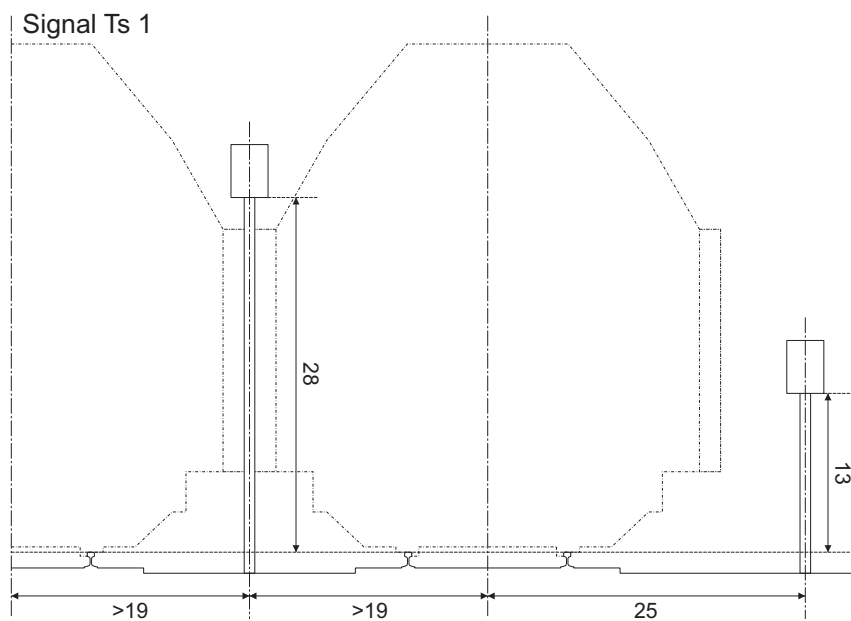
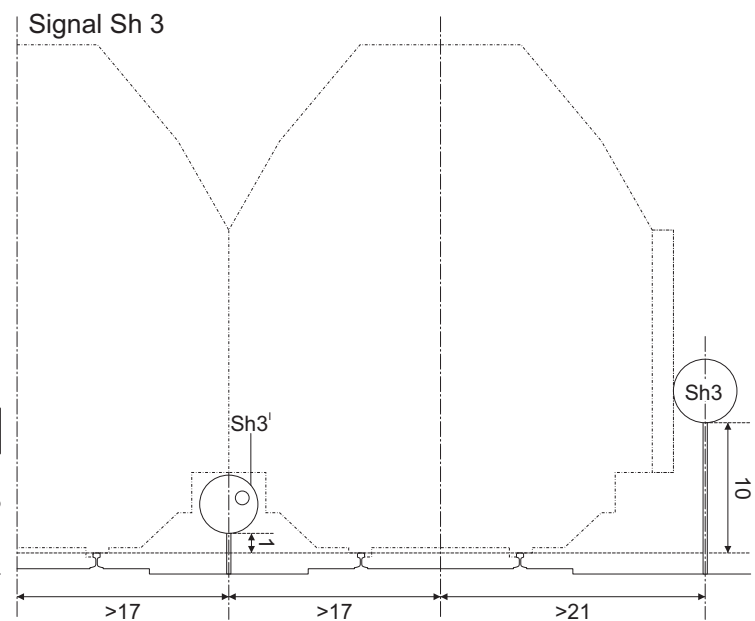
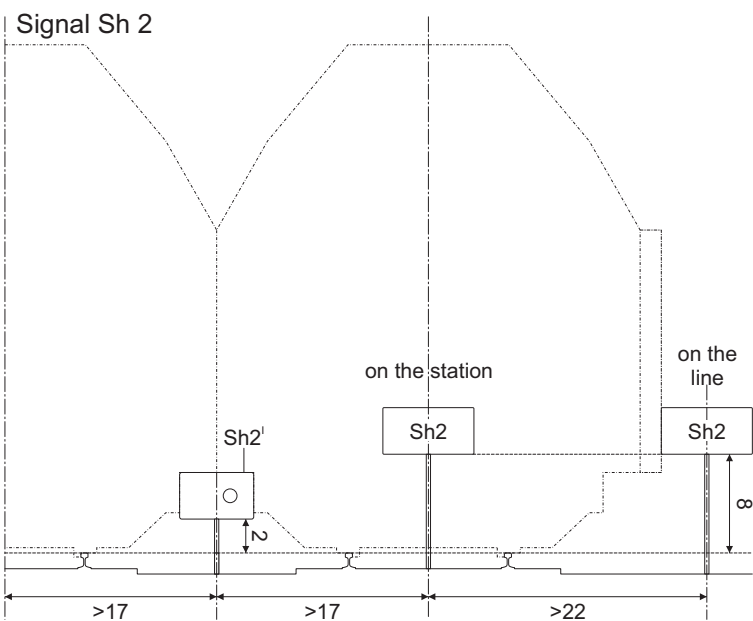
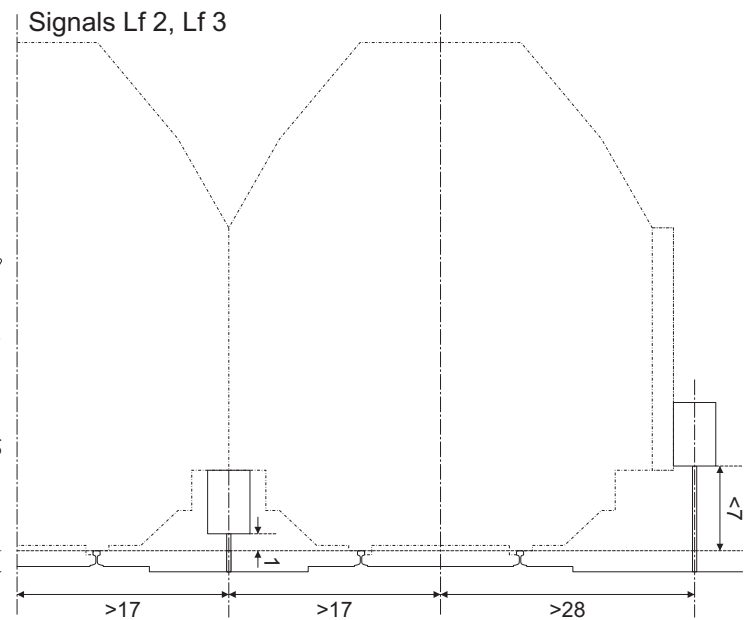
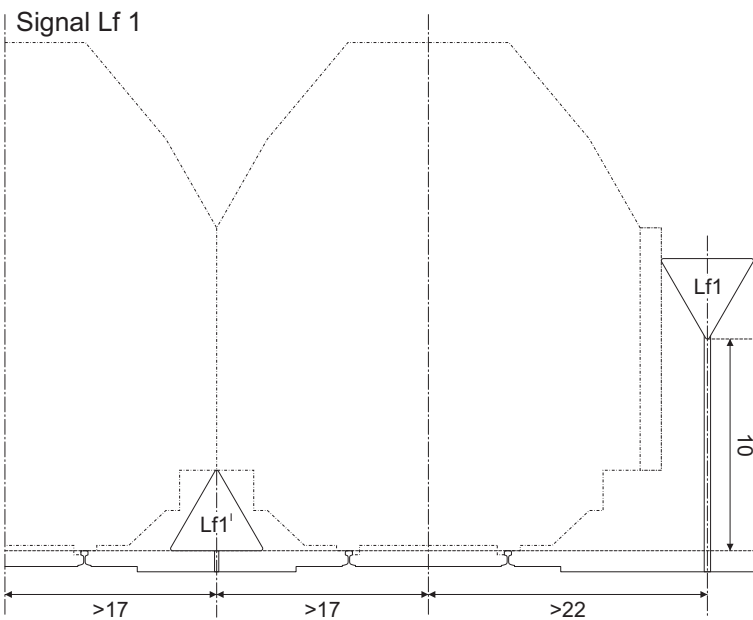

Railway signals and indicators DRG/DR, 1935-1945, scale 1:120 (TT)

Signals placement against the loading gauge 1/4

Indicators K 2, K 4

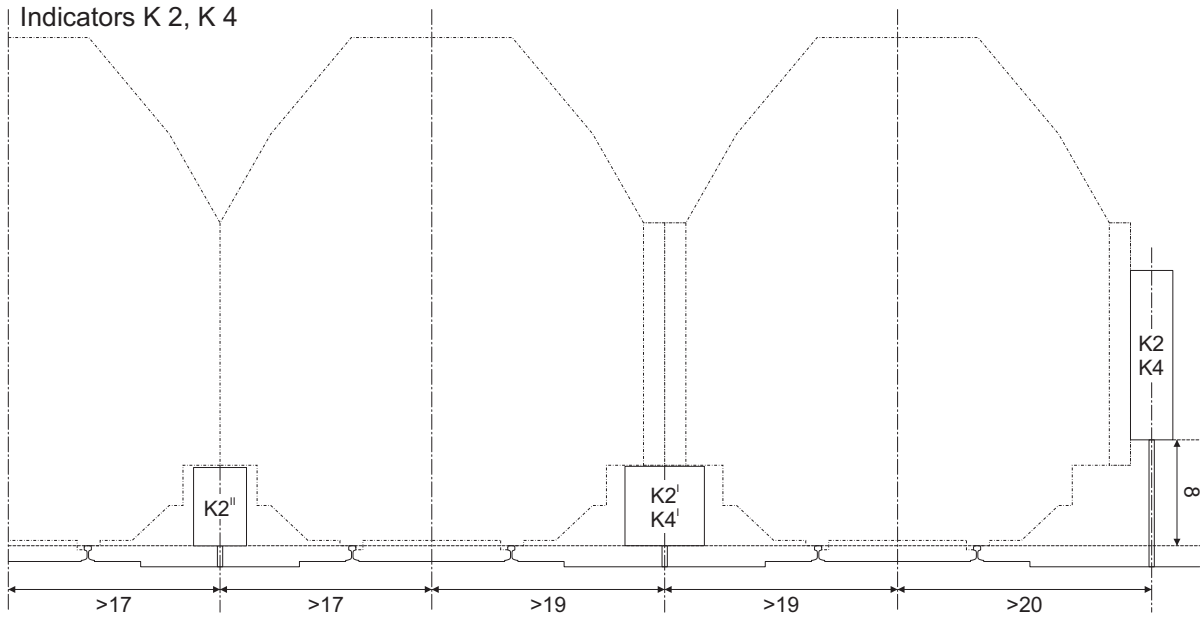

Indicators K 3o, K 3z

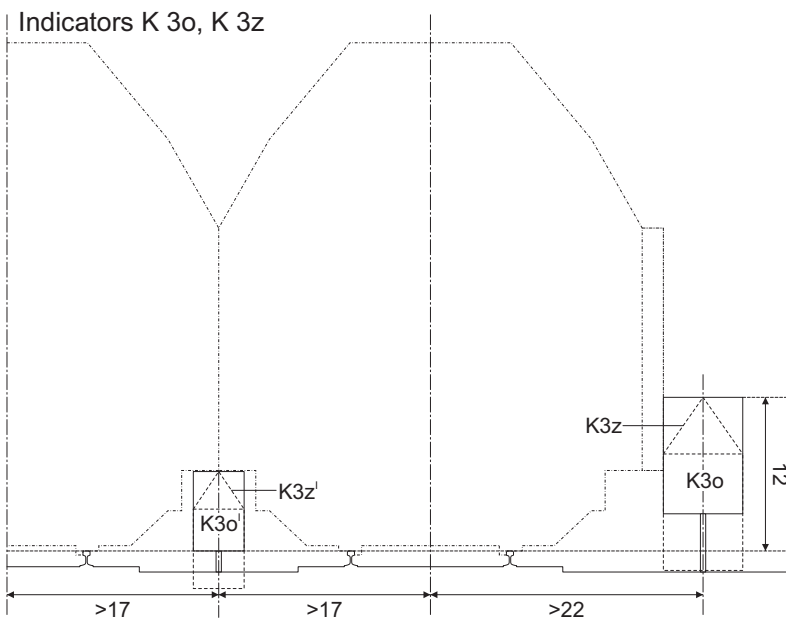

Indicator K 6

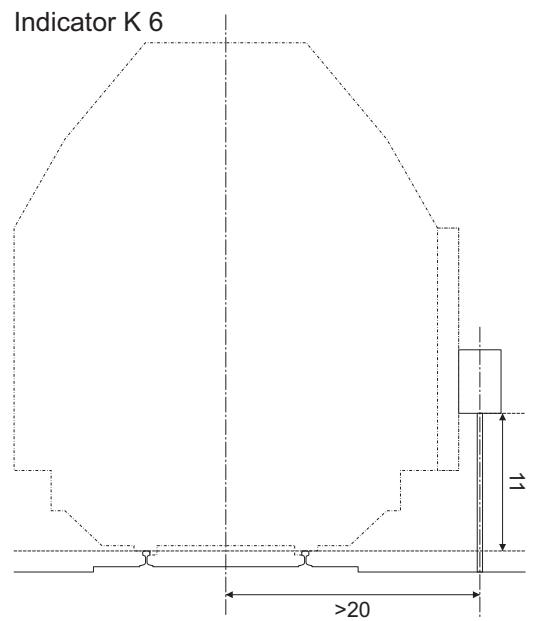

Indicator K 5

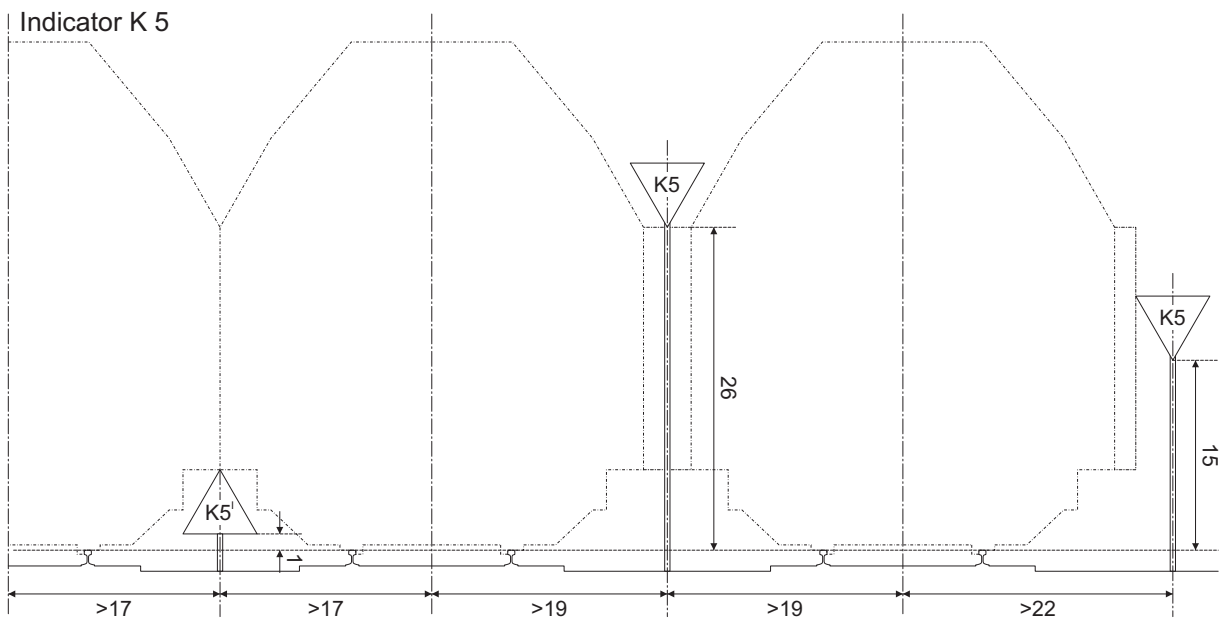

Railway signals and indicators DRG/DR, 1935-1945, scale 1:120 (TT)

Signals placement against the loading gauge 2/4

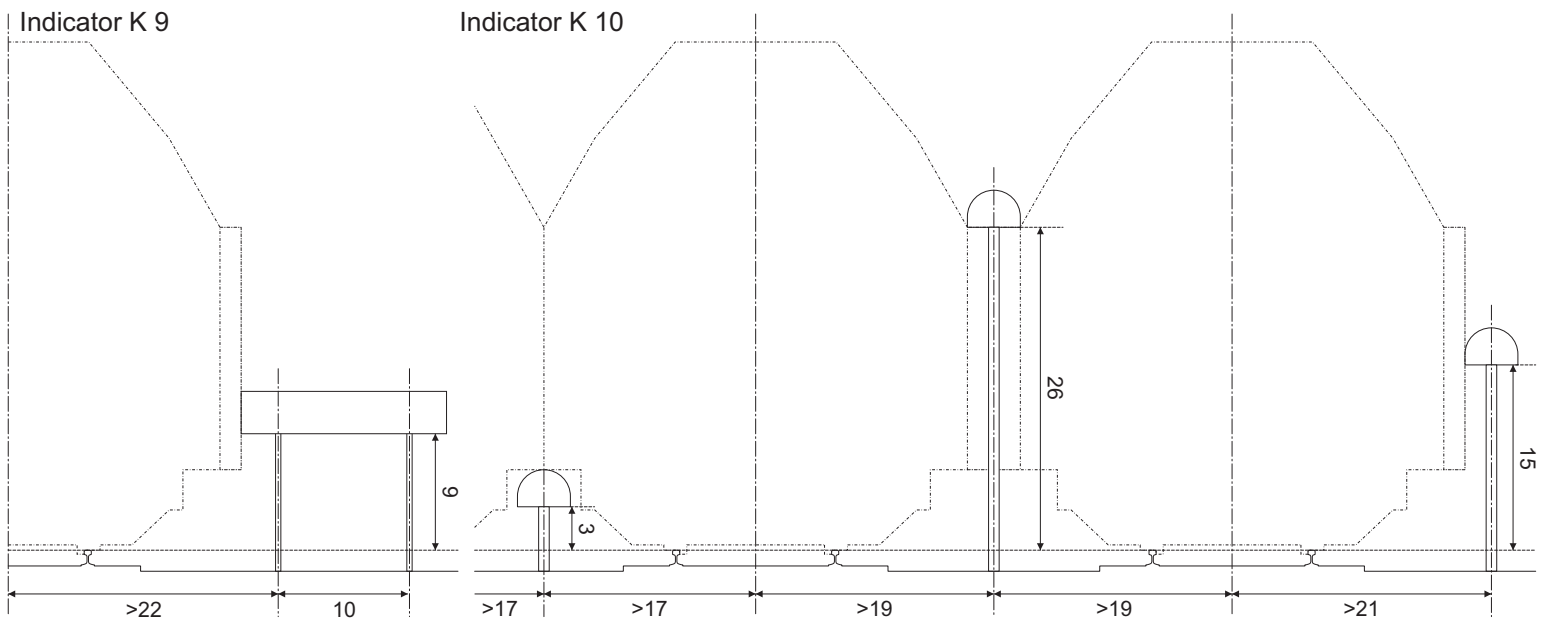
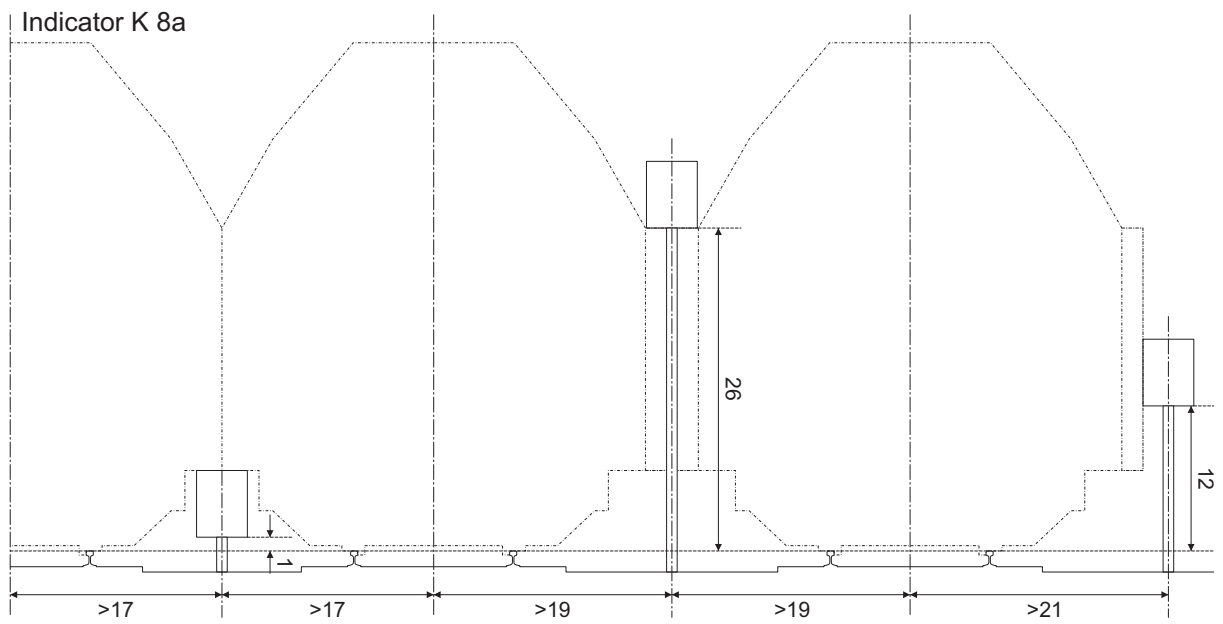
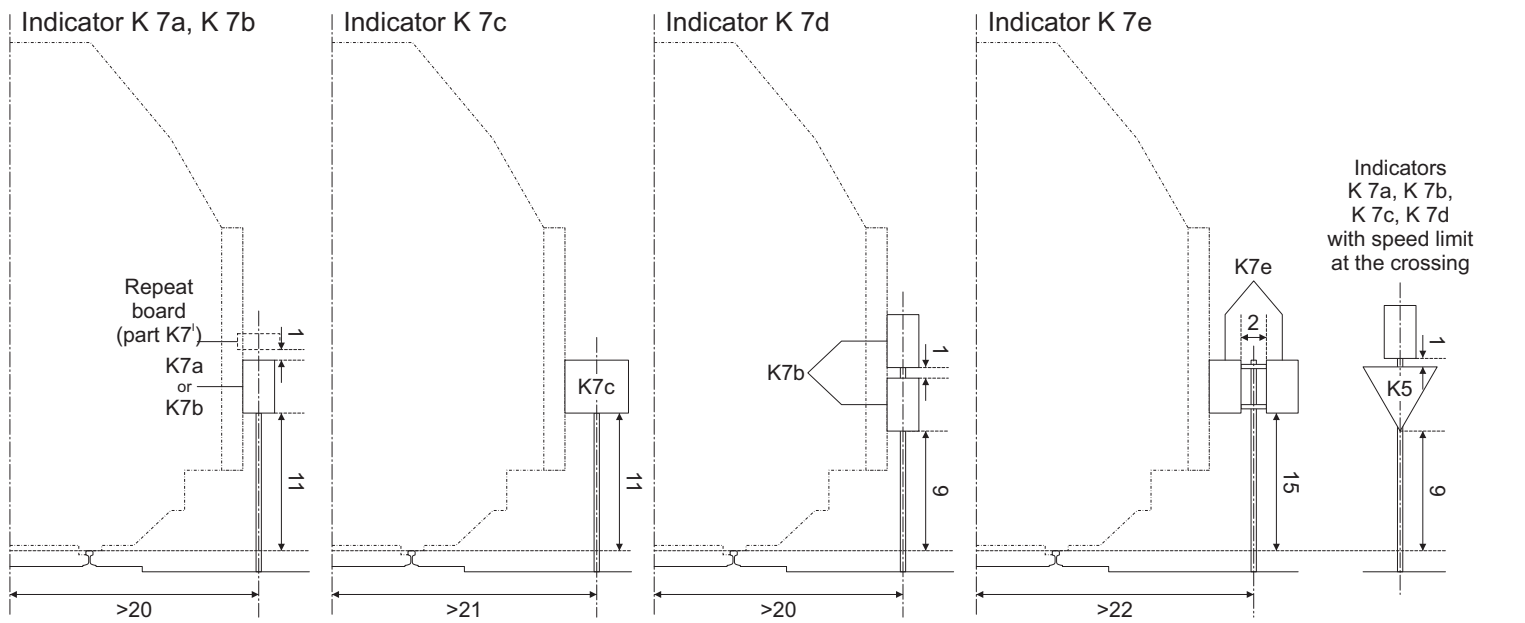

Railway signals and indicators DRG/DR, 1935-1945, scale 1:120 (TT)

Signals placement against the loading gauge 3/4

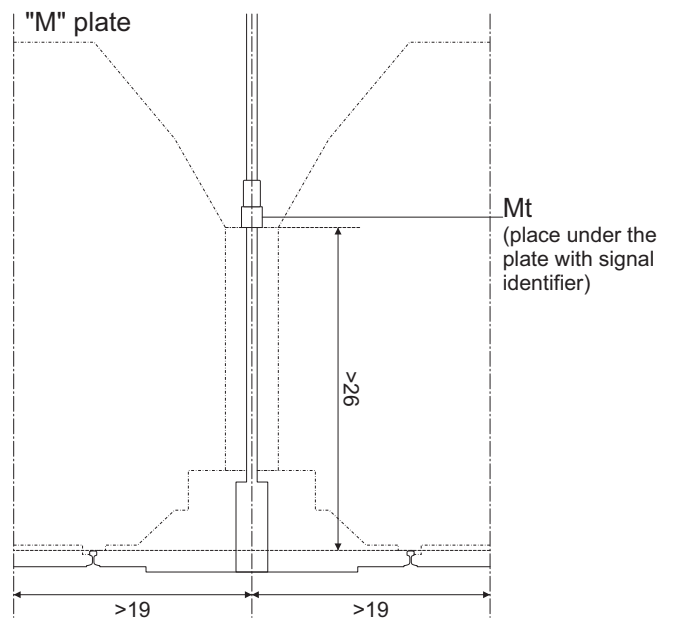
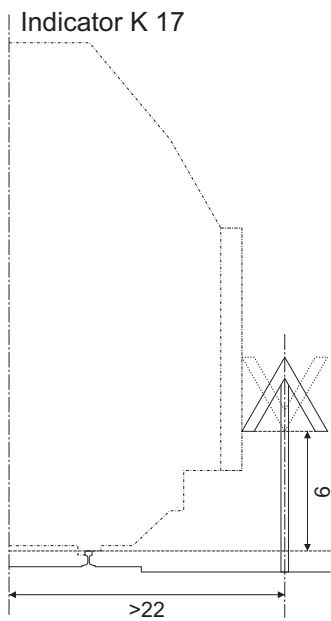
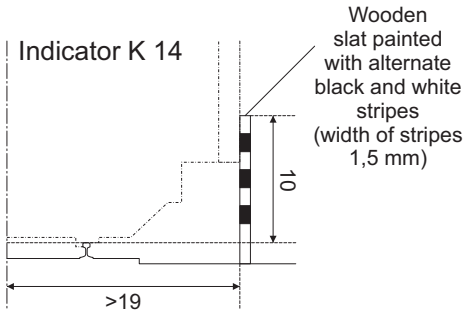
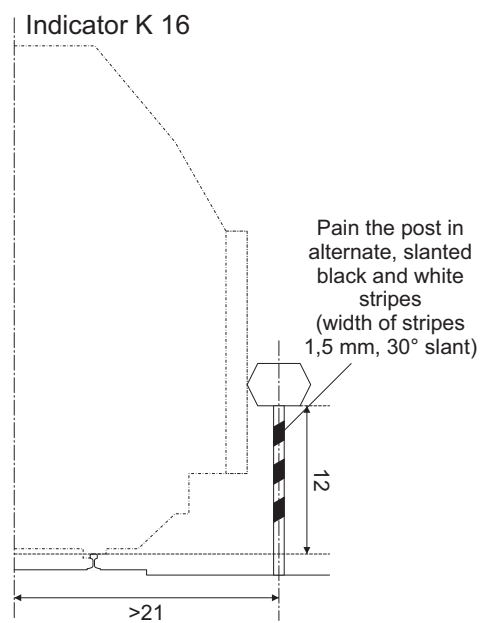
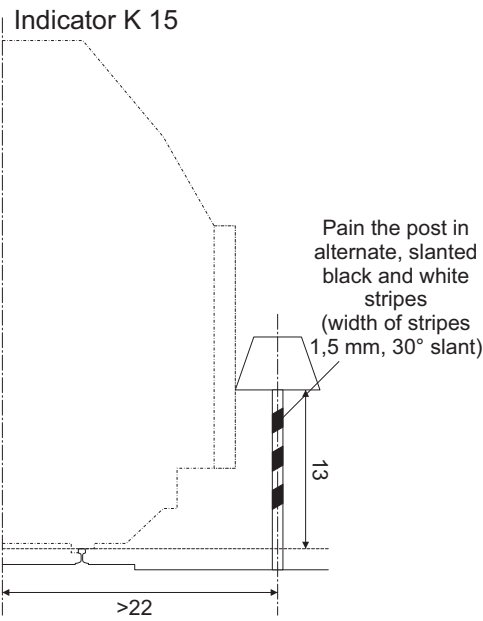
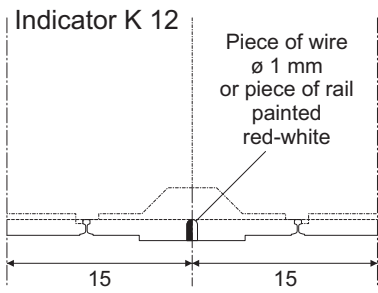

Signals for electrified rail lines EI 1-EI 6, K 8b

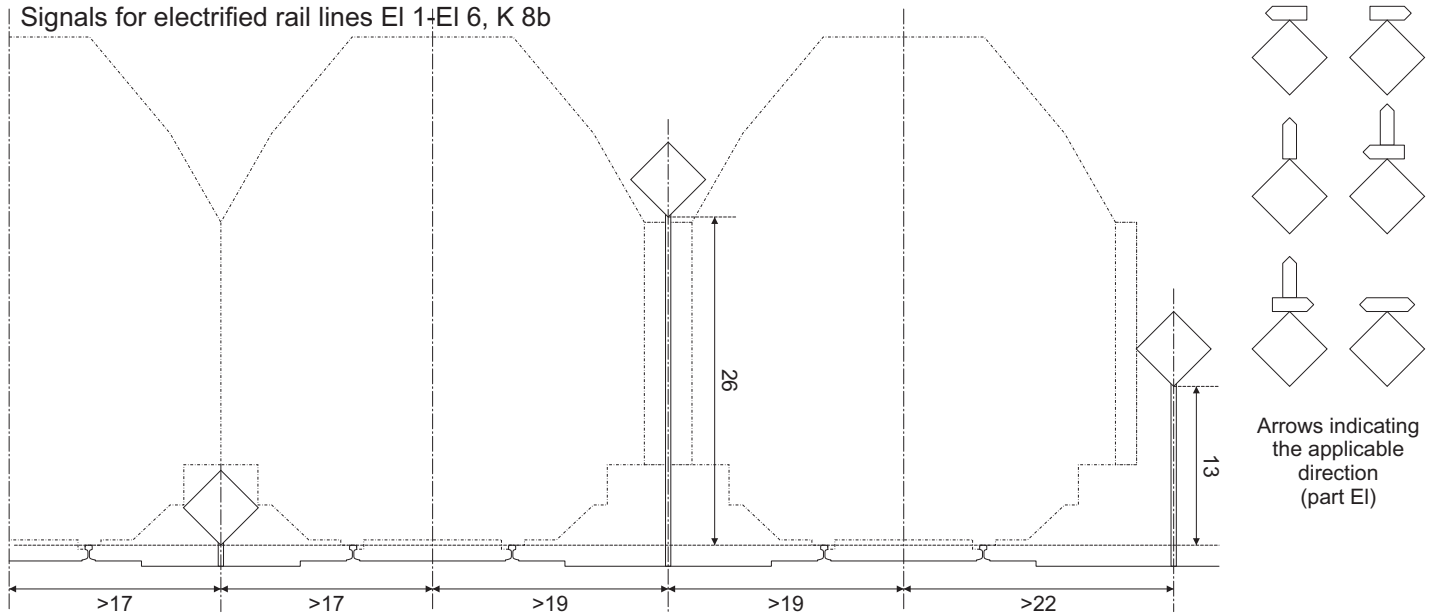

Railway signals and indicators DRG/DR, 1935-1945, scale 1:120 (TT)

Signals placement against the loading gauge 4/4