

Railway signals and indicators DRG/DR, 1935-1945, scale 1:45 (0)

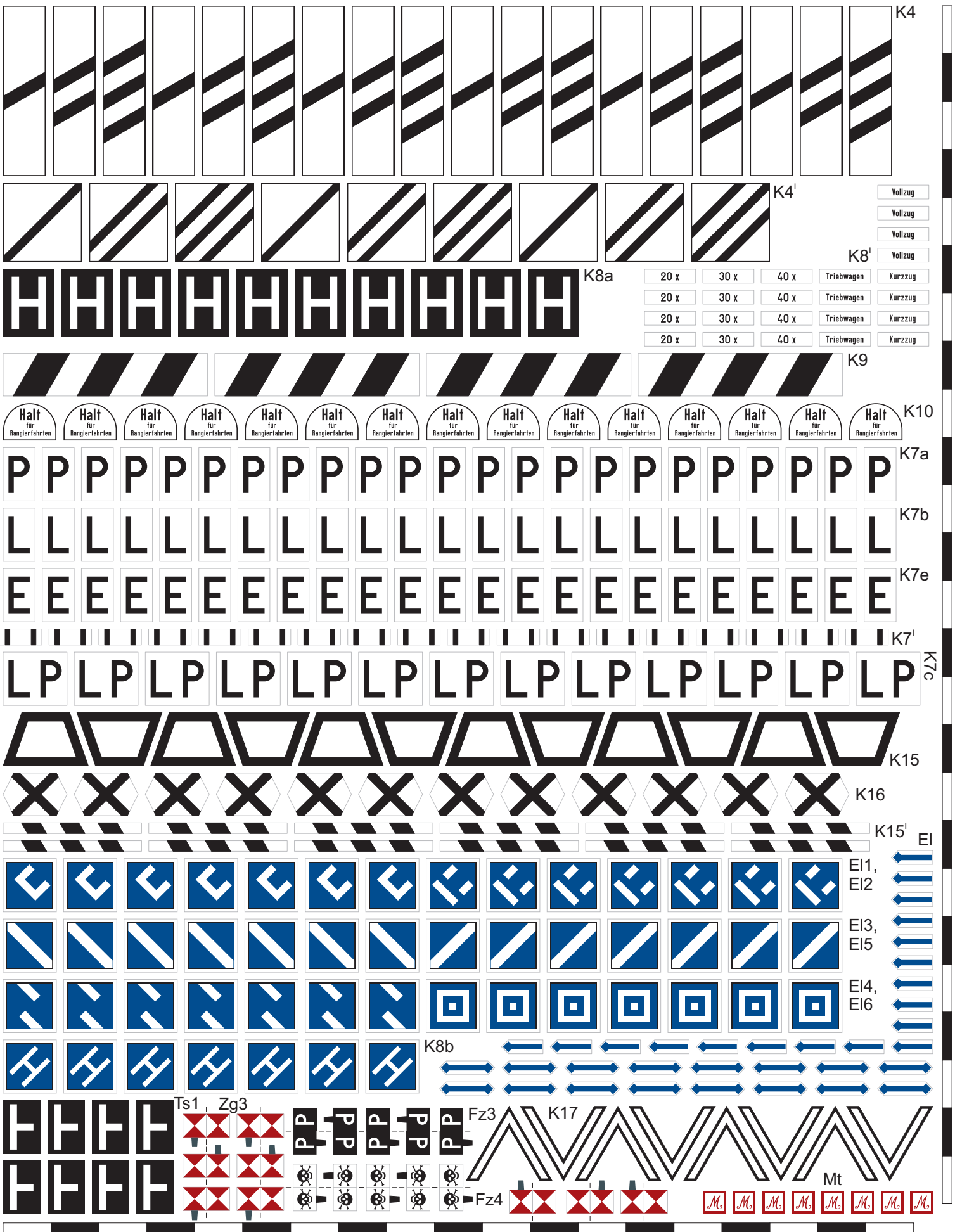

Railway signals and indicators DRG/DR, 1935-1945, scale 1:45 (0)

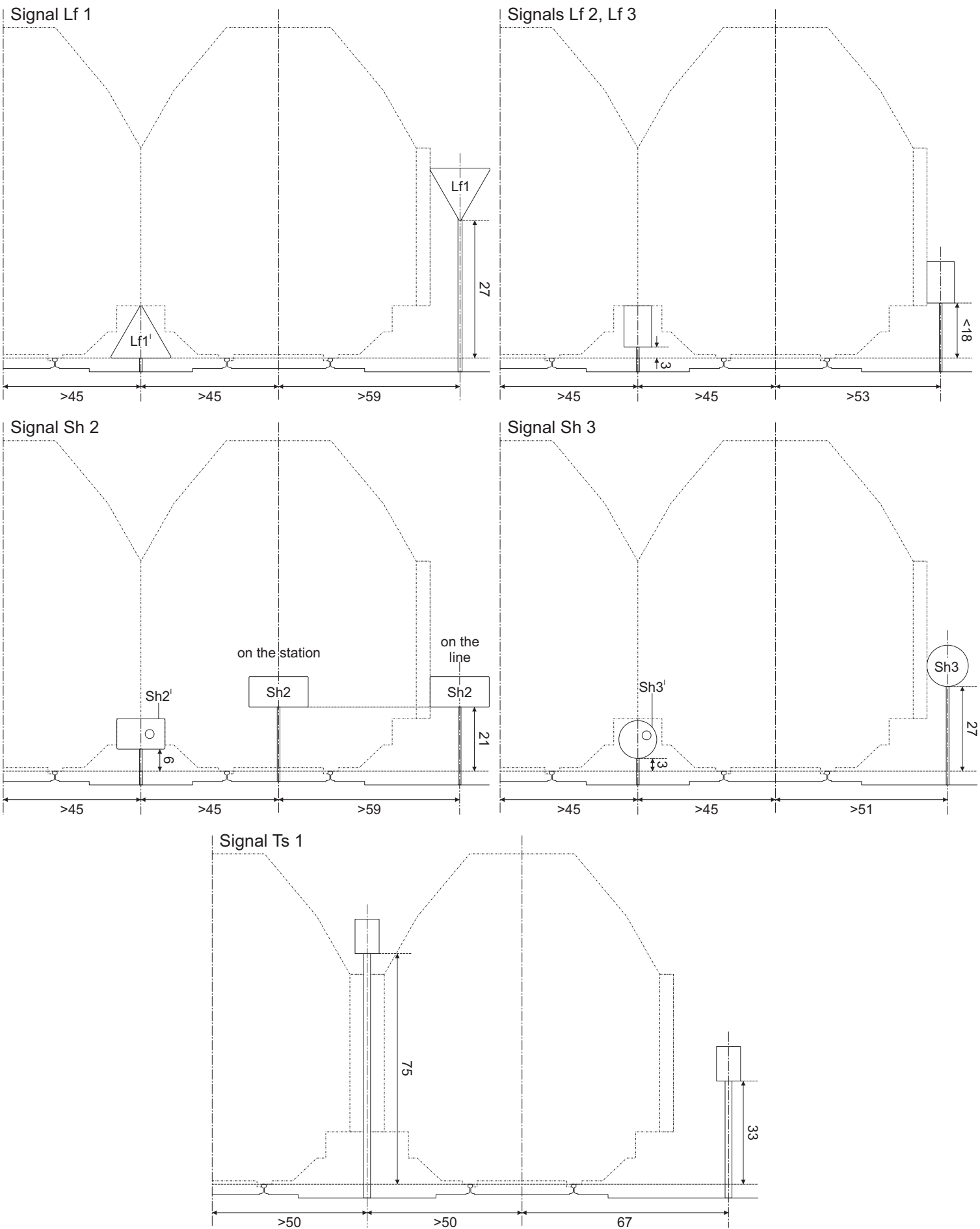

Railway signals and indicators DRG/DR, 1935-1945, scale 1:45 (0)

Signals placement against the loading gauge 1/4

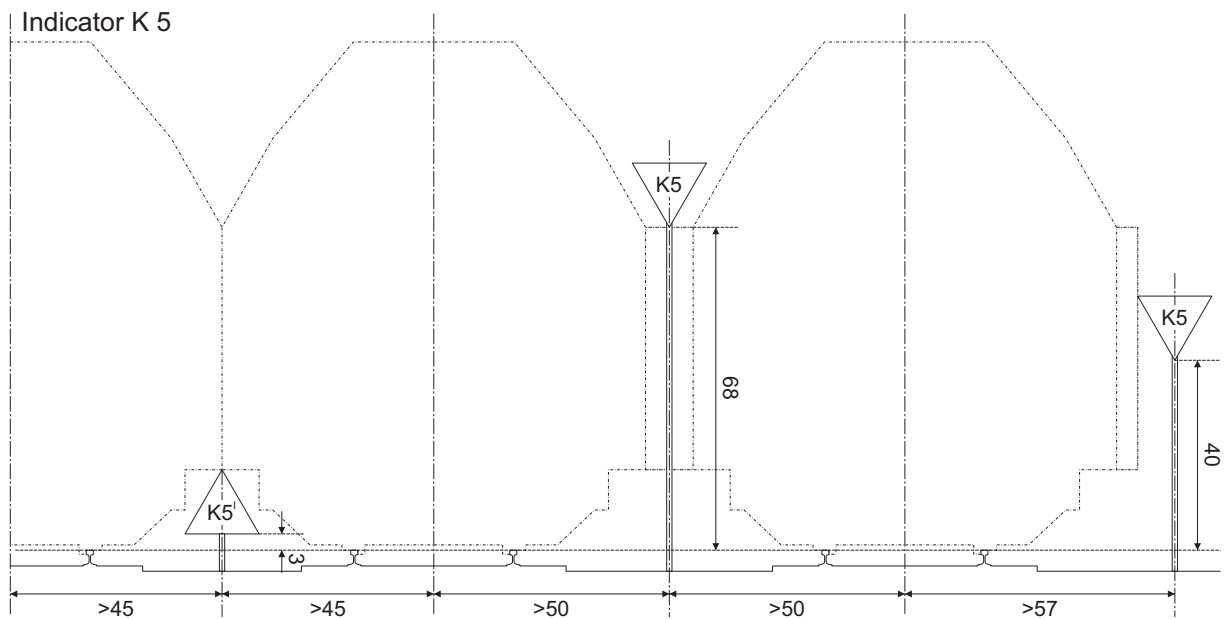
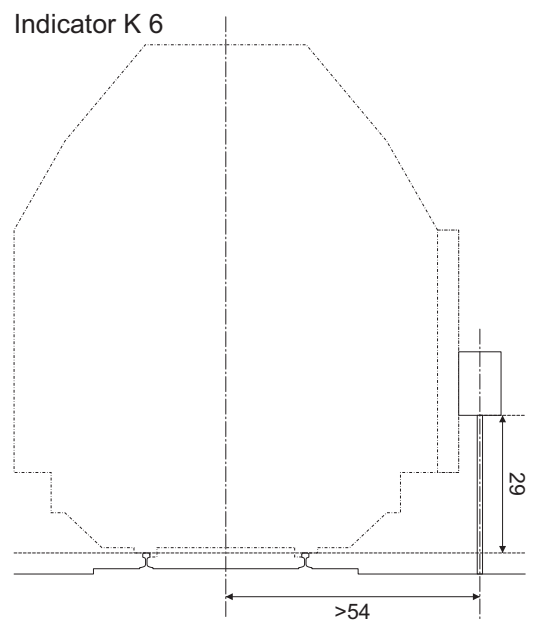
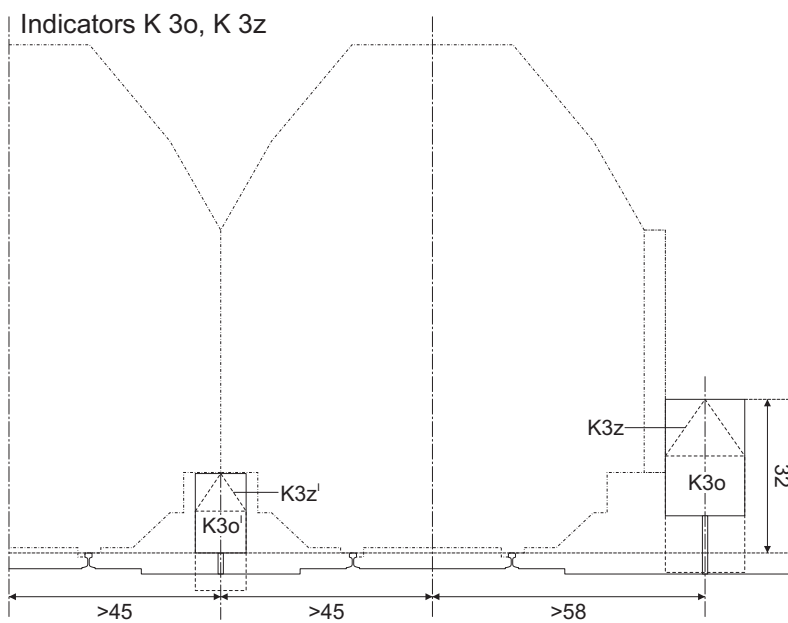
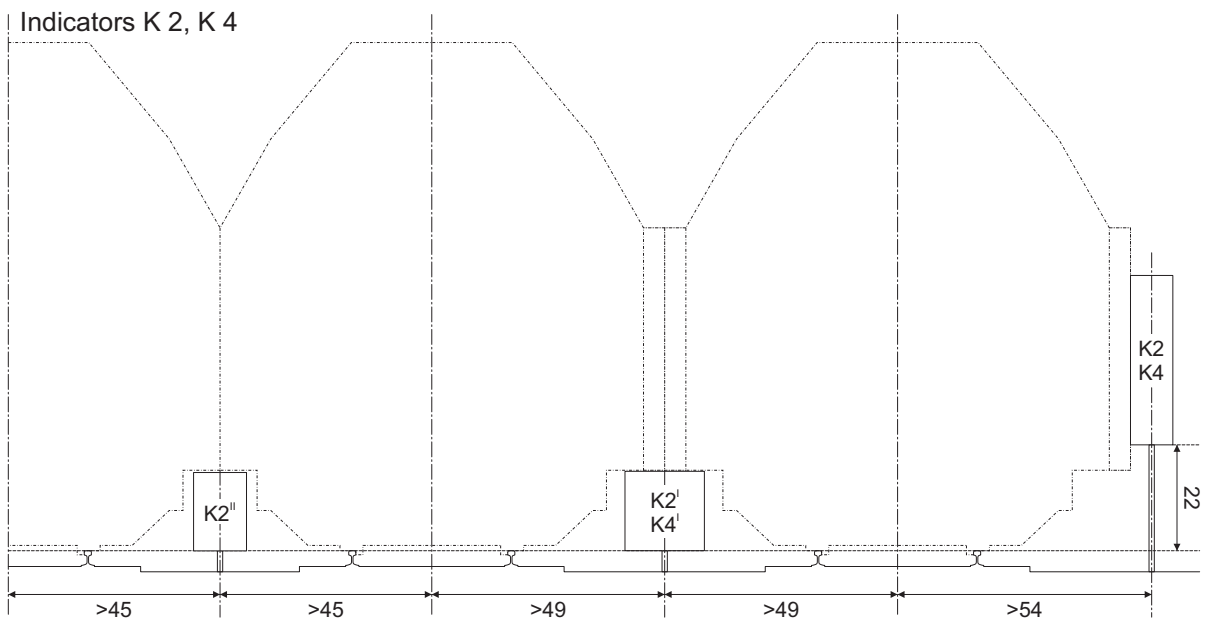

Railway signals and indicators DRG/DR, 1935-1945, scale 1:45 (0)

Signals placement against the loading gauge 2/4

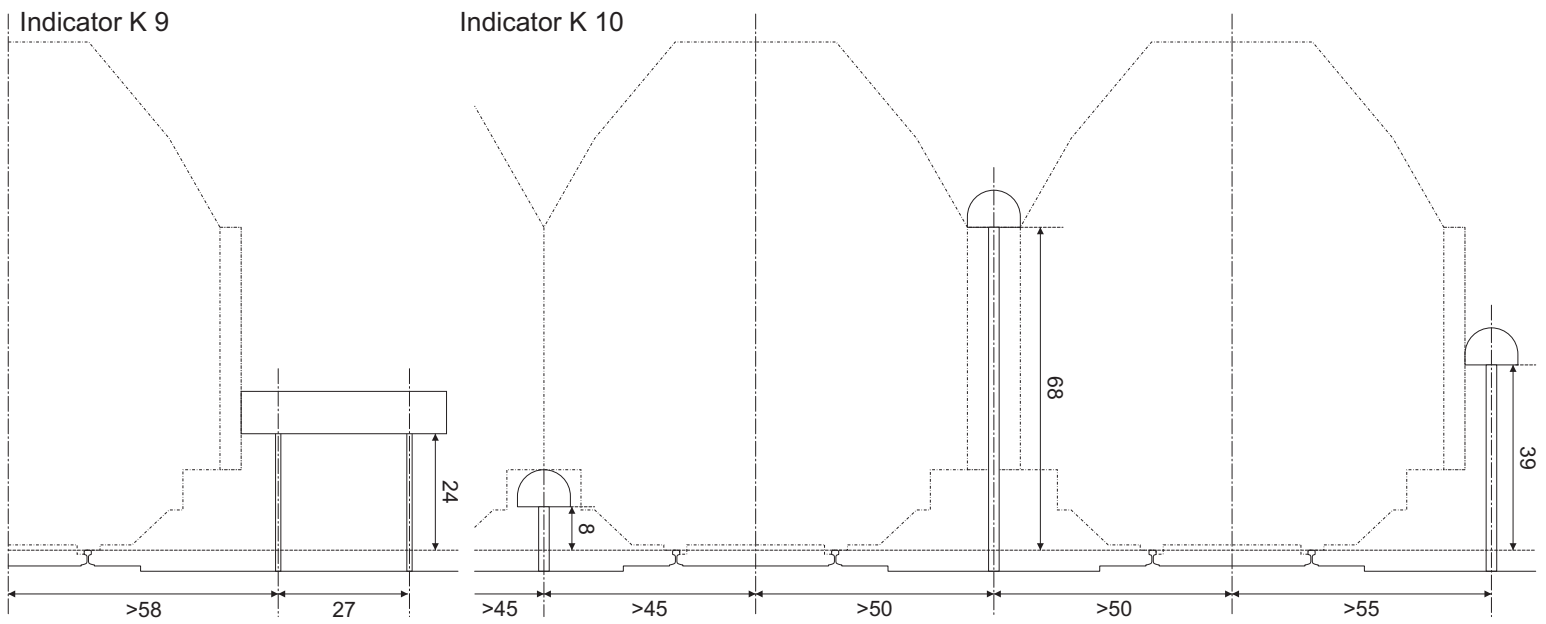
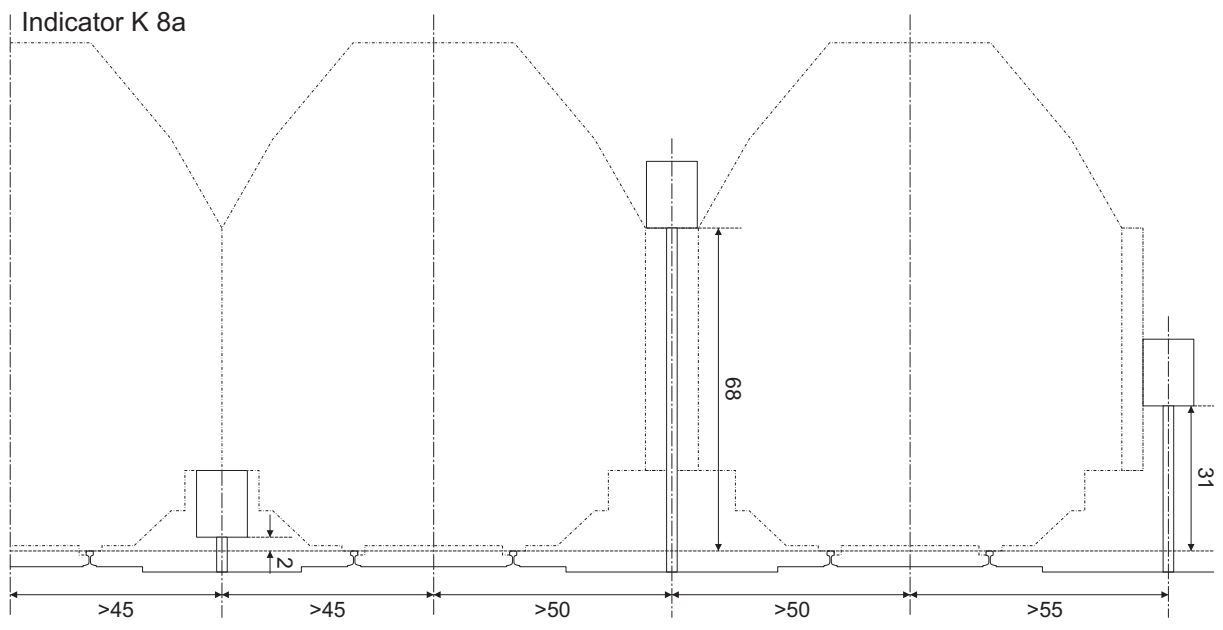
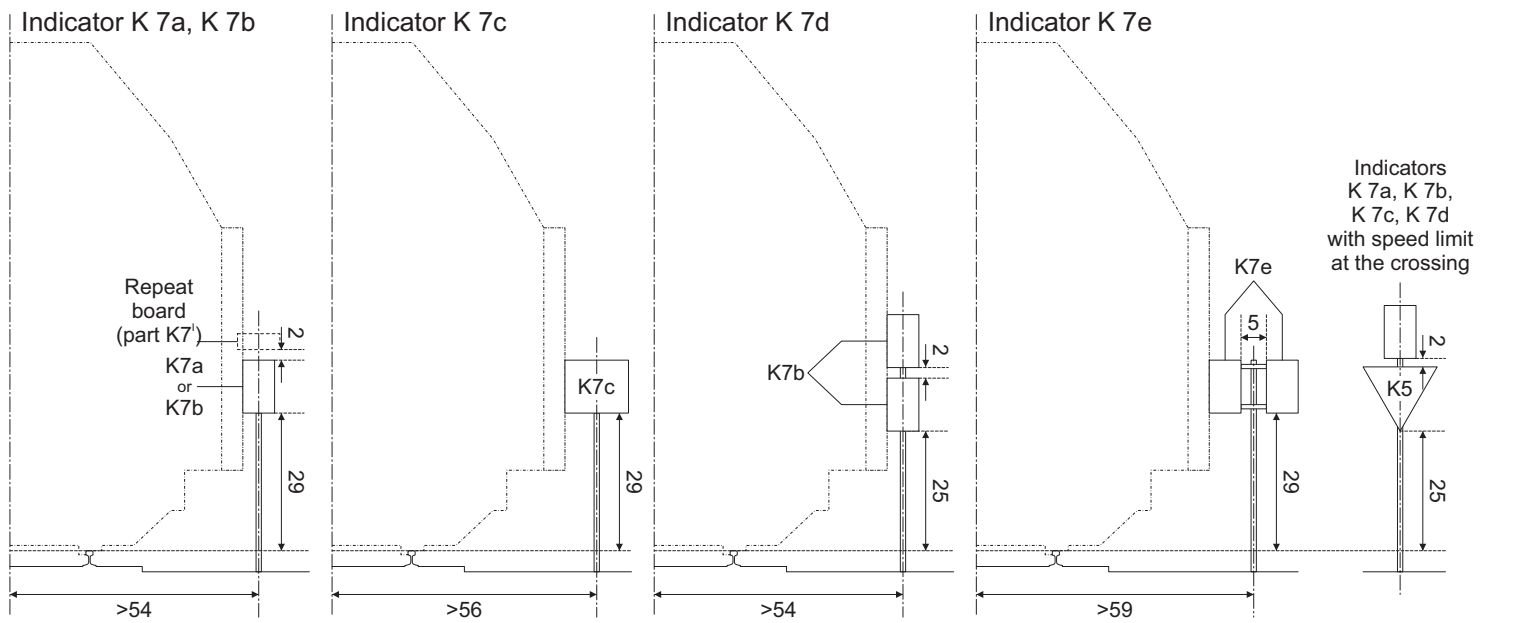

Railway signals and indicators DRG/DR, 1935-1945, scale 1:45 (0)

Signals placement against the loading gauge 3/4

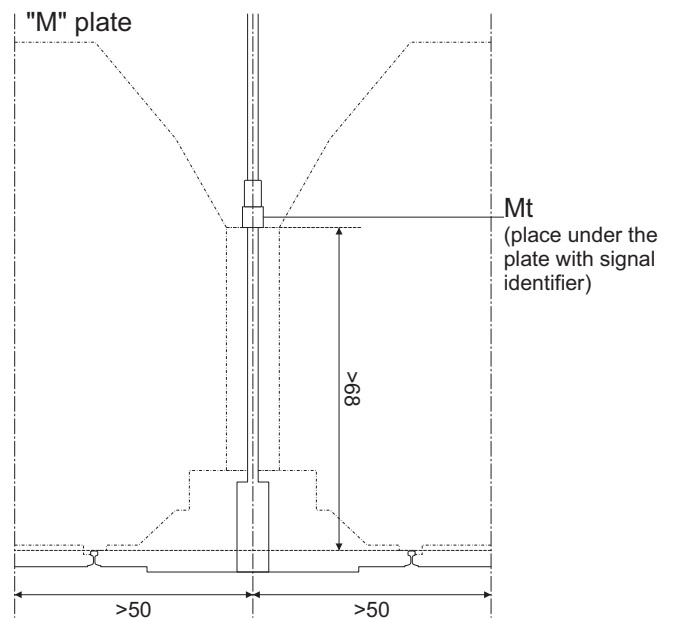
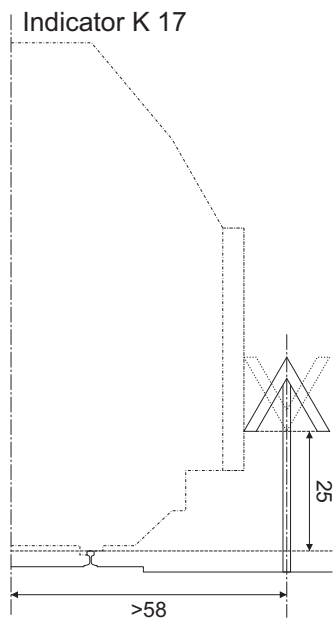
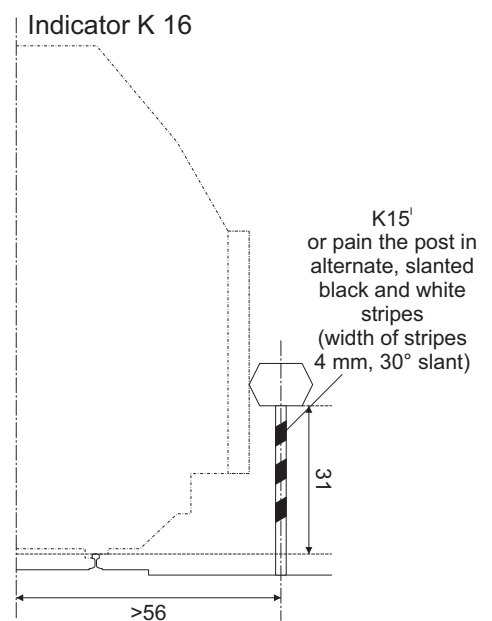
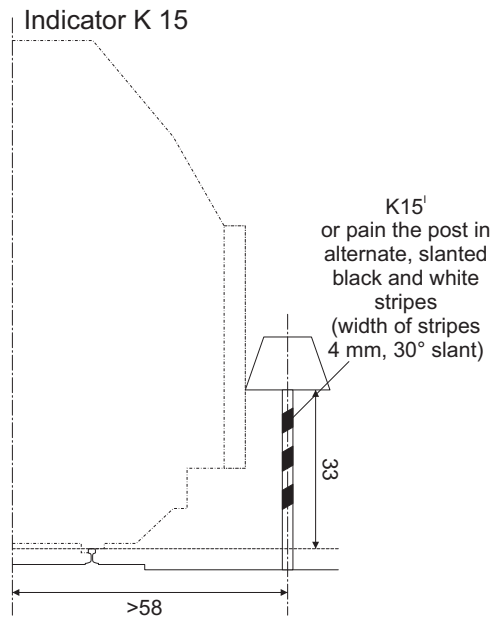
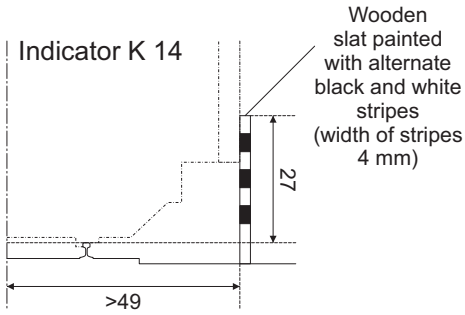
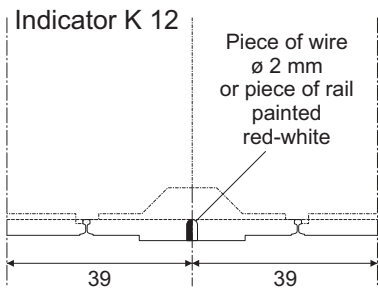

Signals for electrified rail lines EI 1-EI 6, K 8b

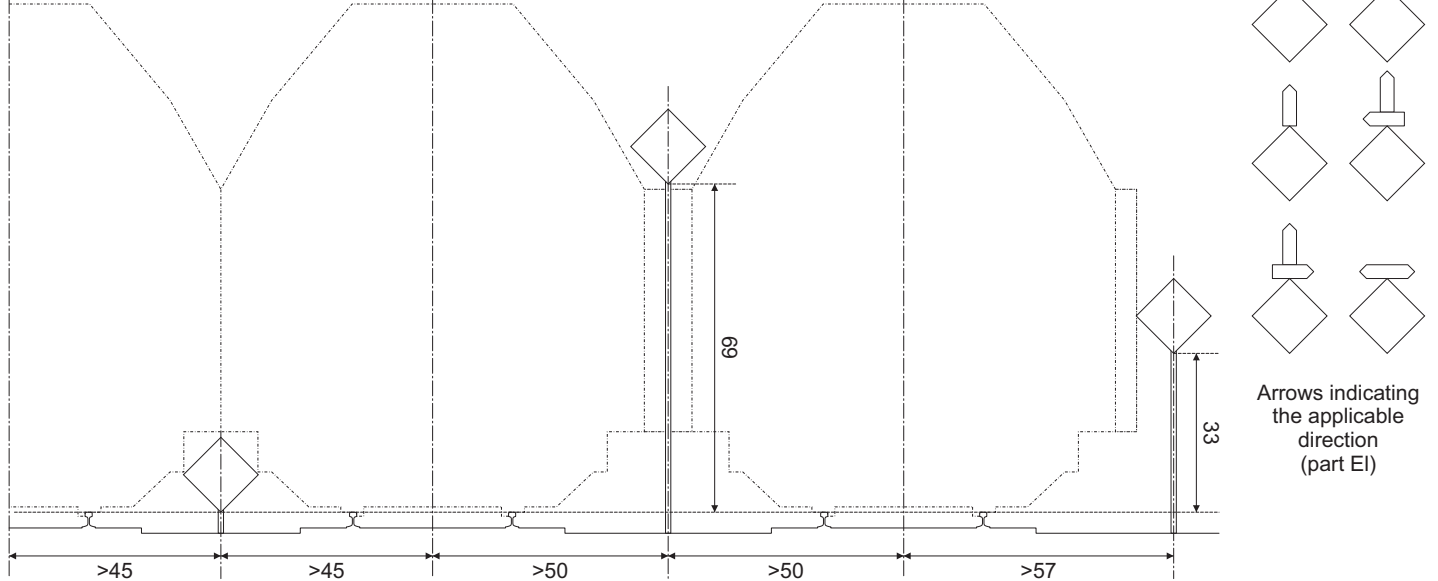

Railway signals and indicators DRG/DR, 1935-1945, scale 1:45 (0)

Signals placement against the loading gauge 4/4