

Railway signals and indicators DRG/DR, 1935-1945, scale 1:25 1cm

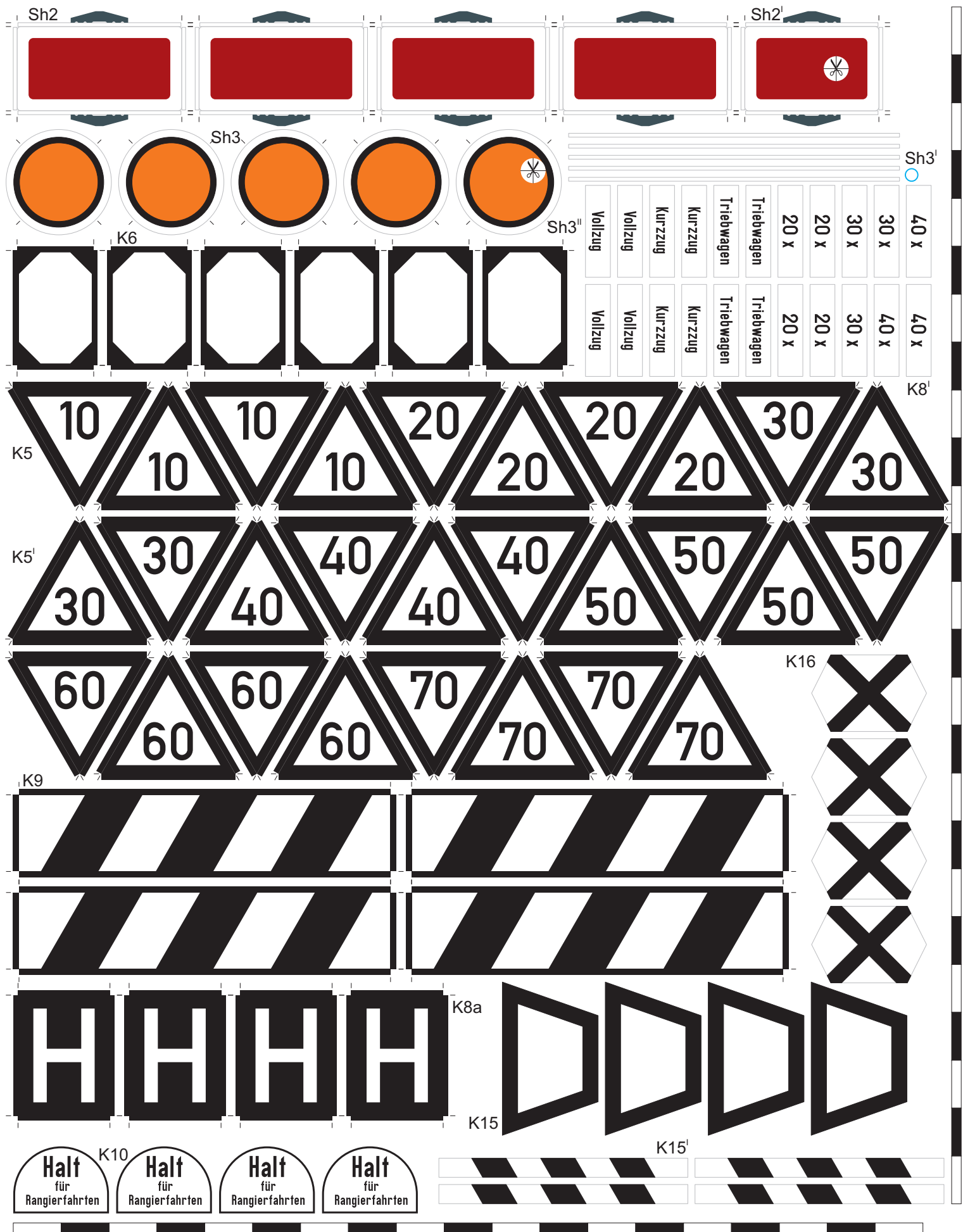

Railway signals and indicators DRG/DR, 1935-1945, scale 1:25

1cm

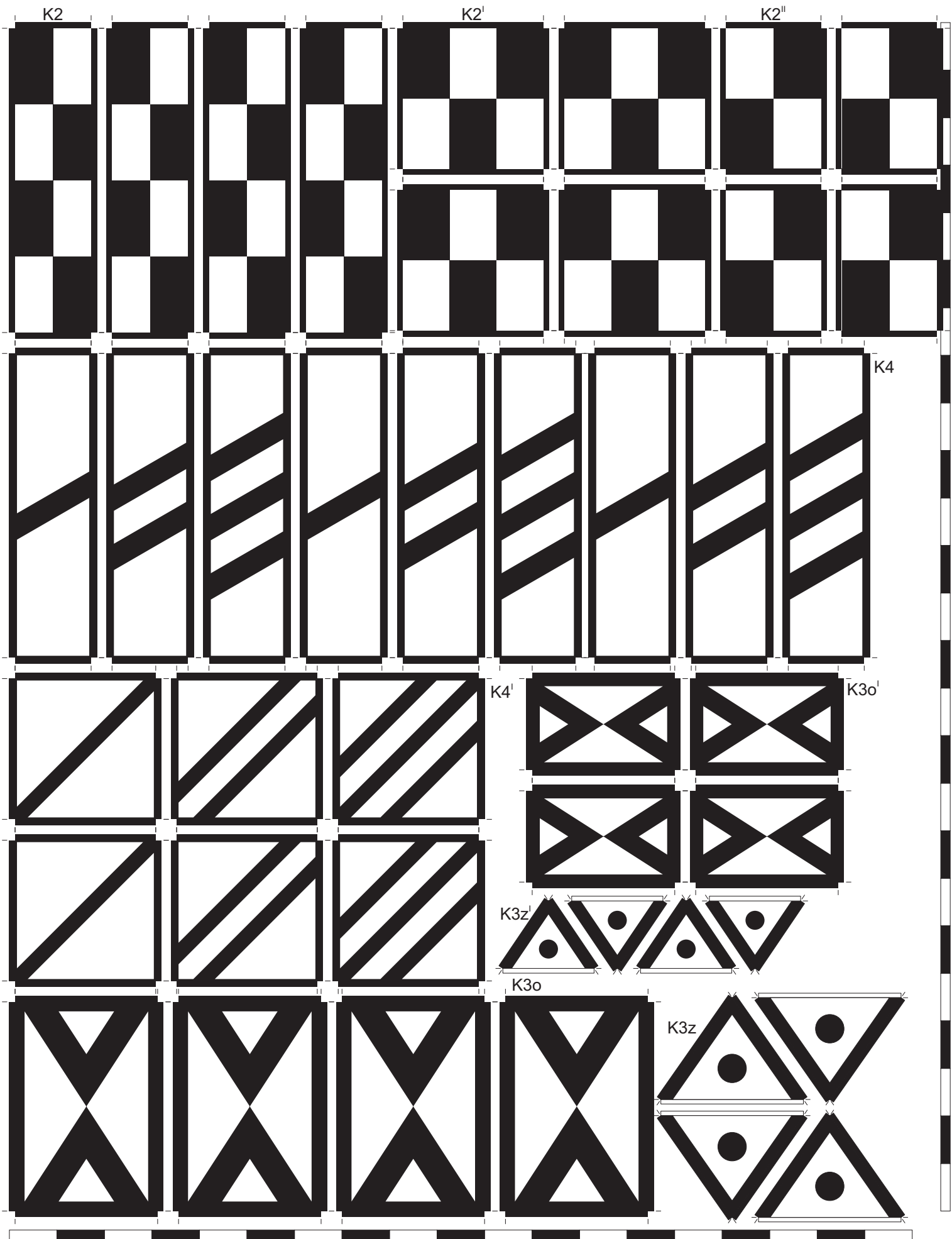

Railway signals and indicators DRG/DR, 1935-1945, scale 1:25

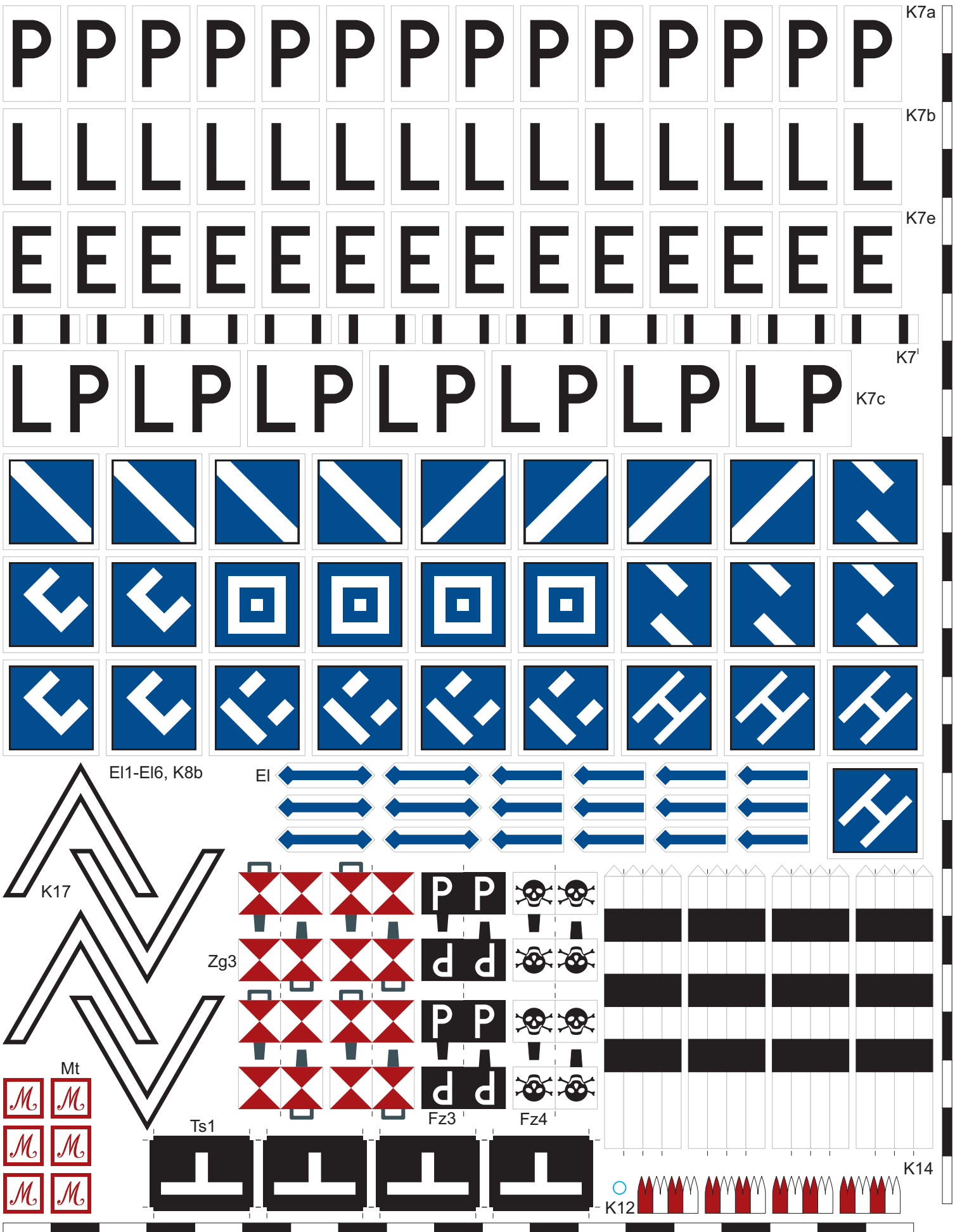

Railway signals and indicators DRG/DR, 1935-1945, scale 1:25

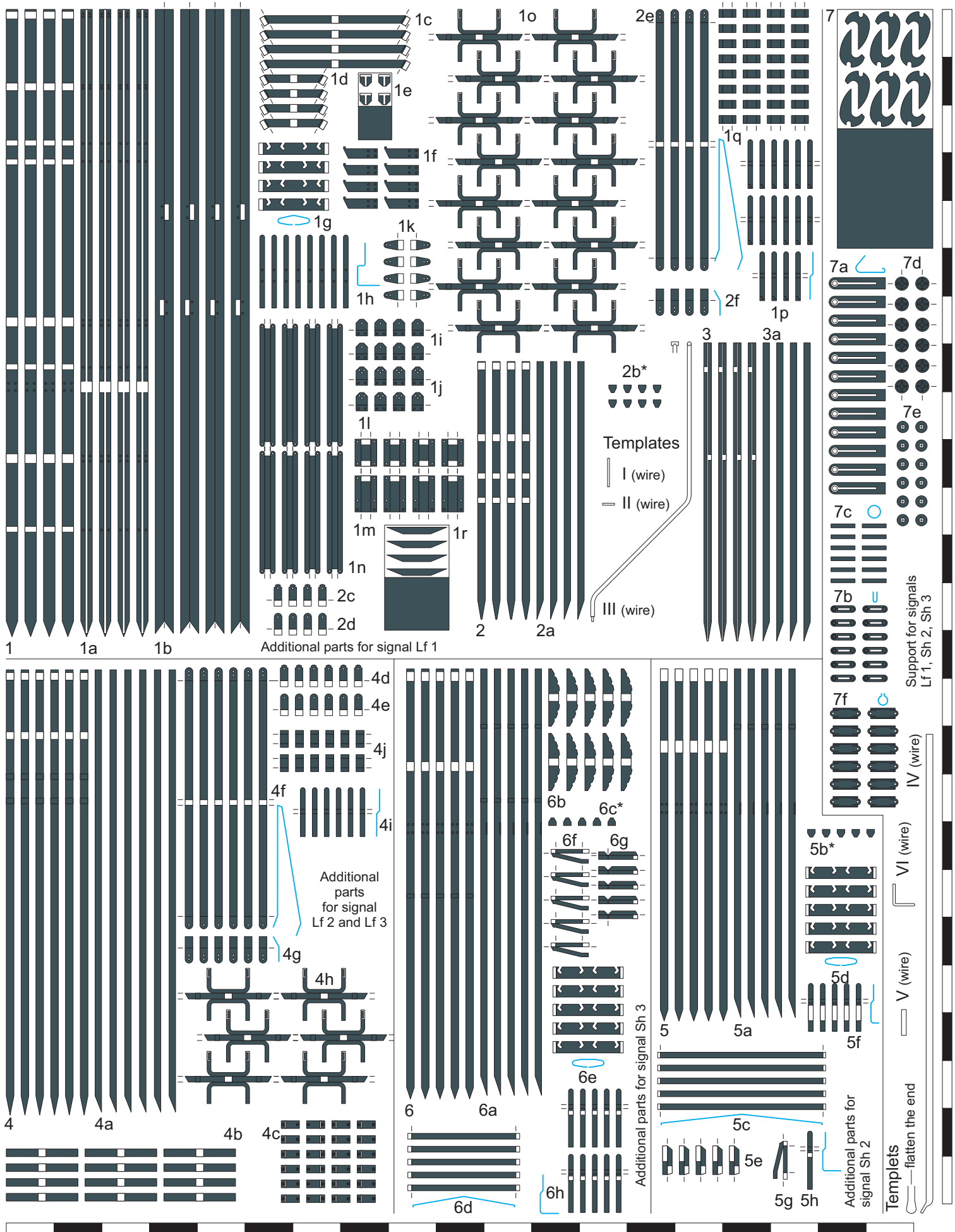

Railway signals and indicators DRG/DR, 1935-1945, scale 1:25

Additional parts

Author: Paweł Adamowicz (<http://pkprepo.net/>), 2021/2022, selected rights reserved

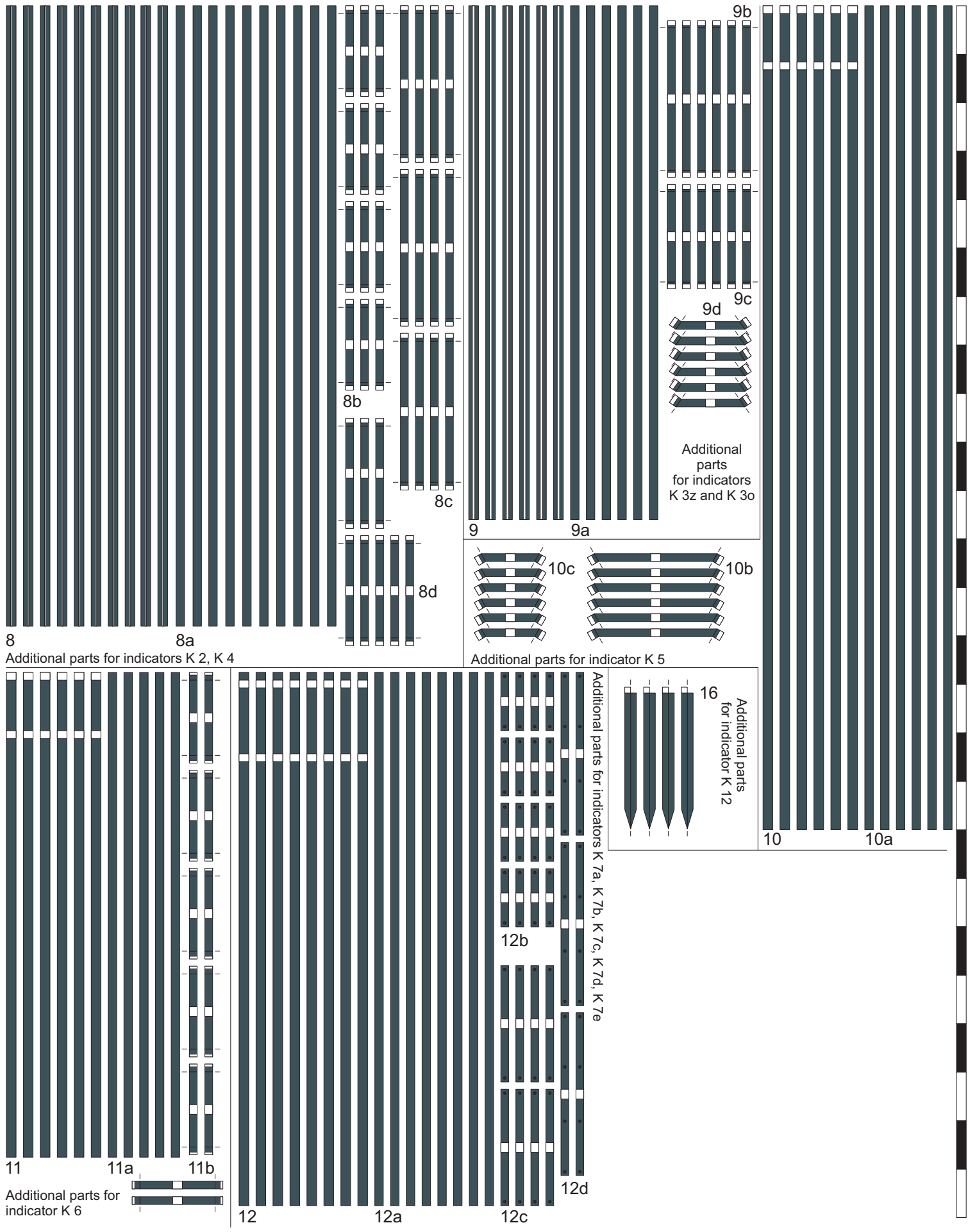

8
8a
Additional parts for indicators K 2, K 4

9
9a
Additional parts for indicator K 5

Additional parts for indicators K 3z and K 3o

11
11a
11b
Additional parts for indicator K 6

16
Additional parts for indicator K 12

12
12a
12b
12c
12d
Additional parts for indicators K 7a, K 7b, K 7c, K 7d, K 7e

Railway signals and indicators DRG/DR, 1935-1945, scale 1:25

Additional parts

1cm

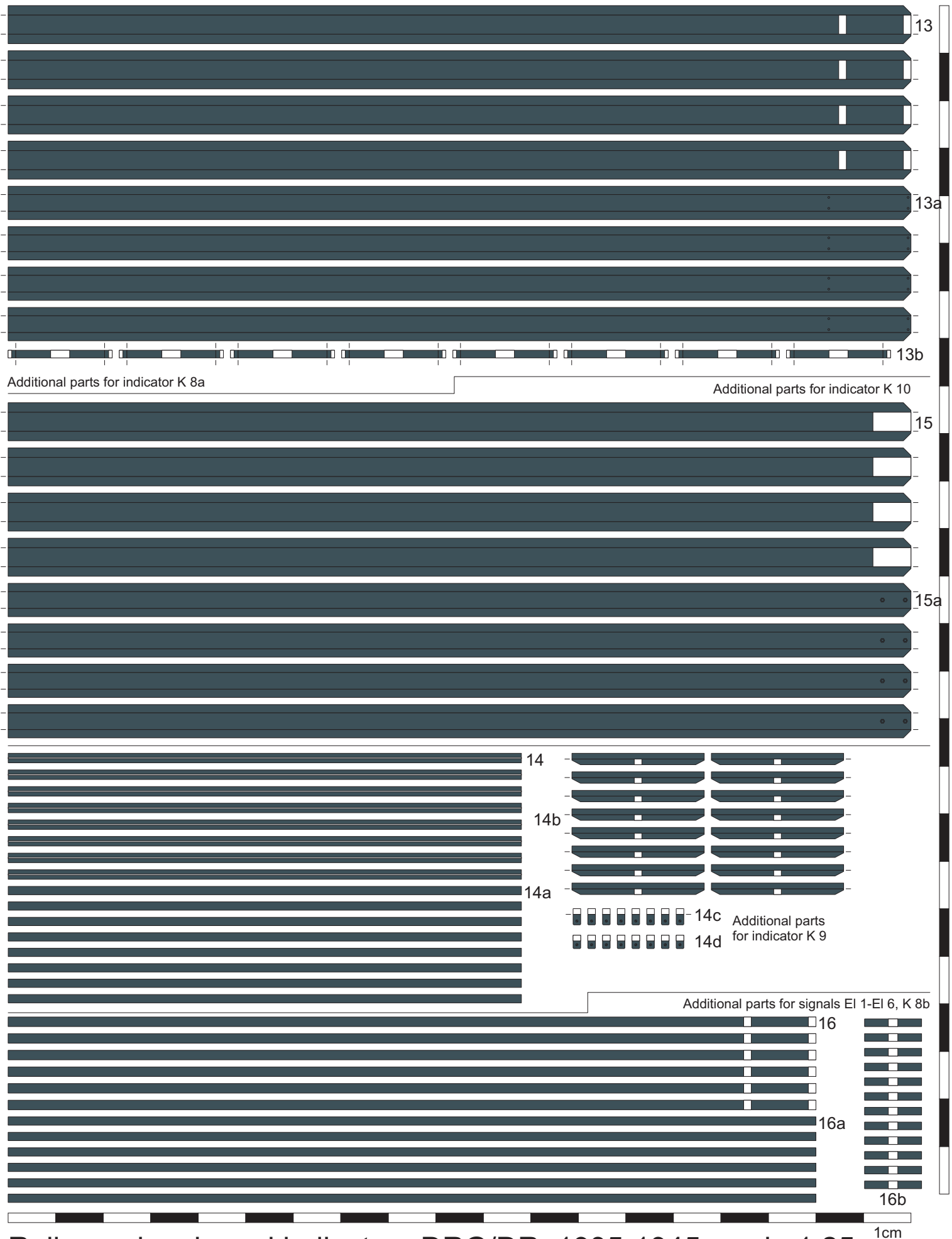

Railway signals and indicators DRG/DR, 1935-1945, scale 1:25

Additional parts

Author: Paweł Adamowicz (<http://pkprepo.net/>), 2021/2022, selected rights reserved 

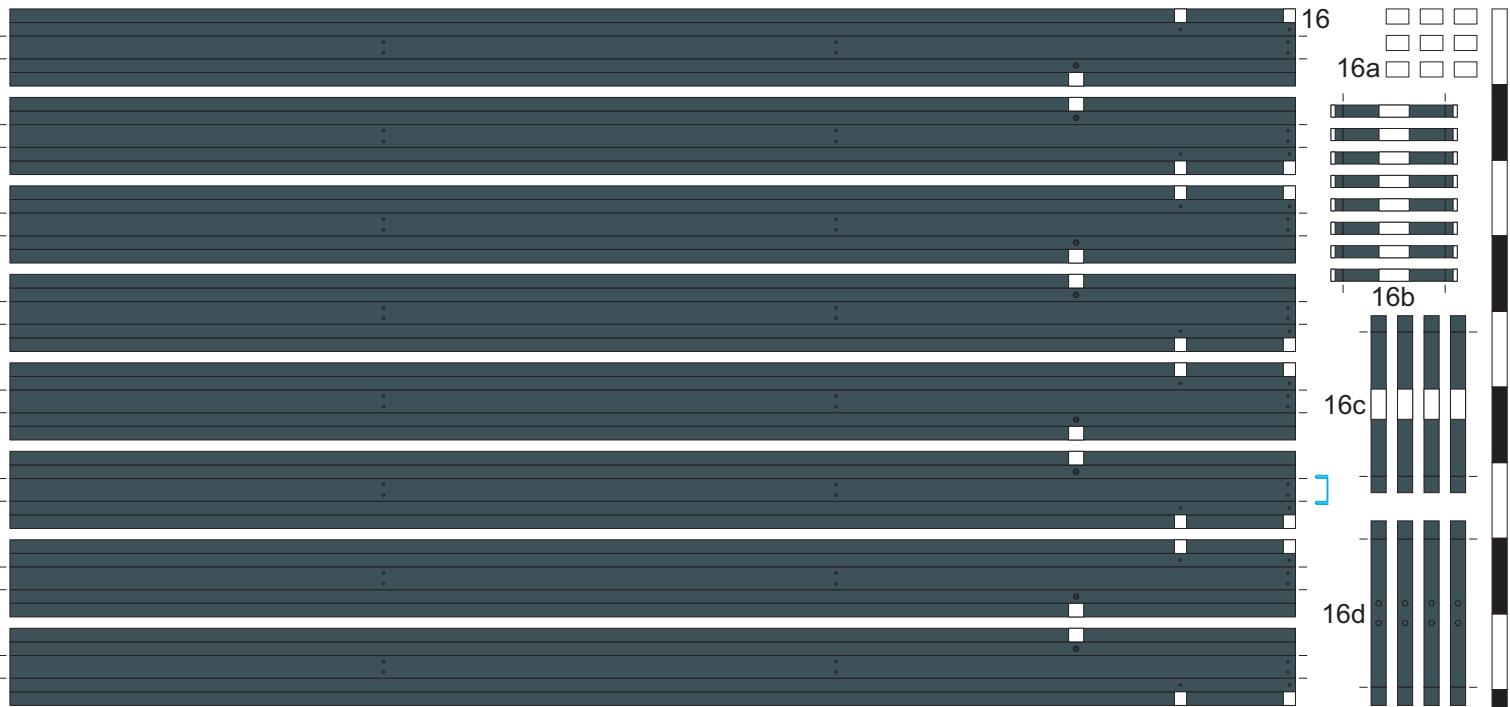

Additional parts for signal Ts 1

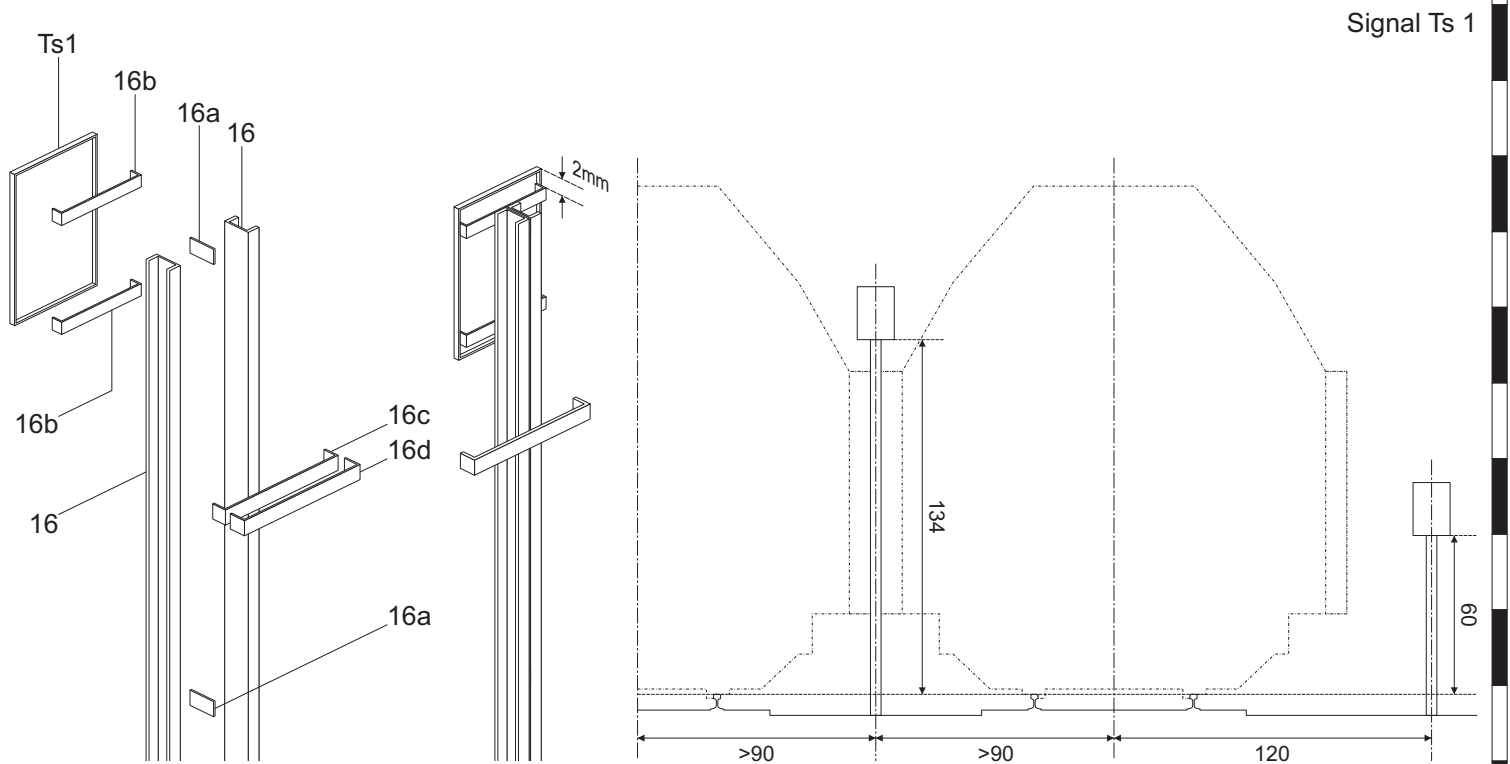

Railway signals and indicators DRG/DR, 1935-1945, scale 1:25

Additional parts, assembly manual 1/10

Signal Lf 1

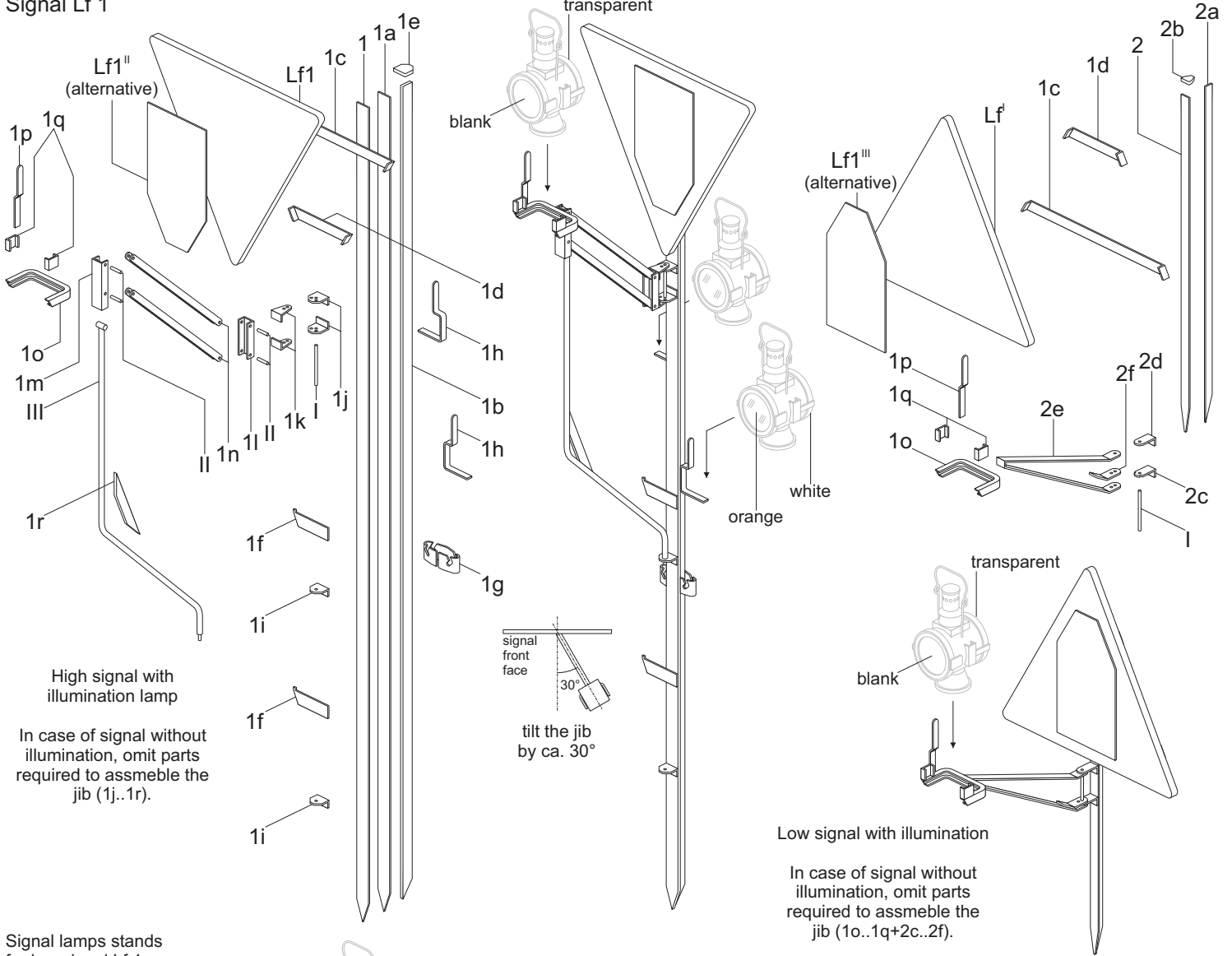

Signal lamps stands for low signal Lf 1 (place ~150 mm in front of the signal).

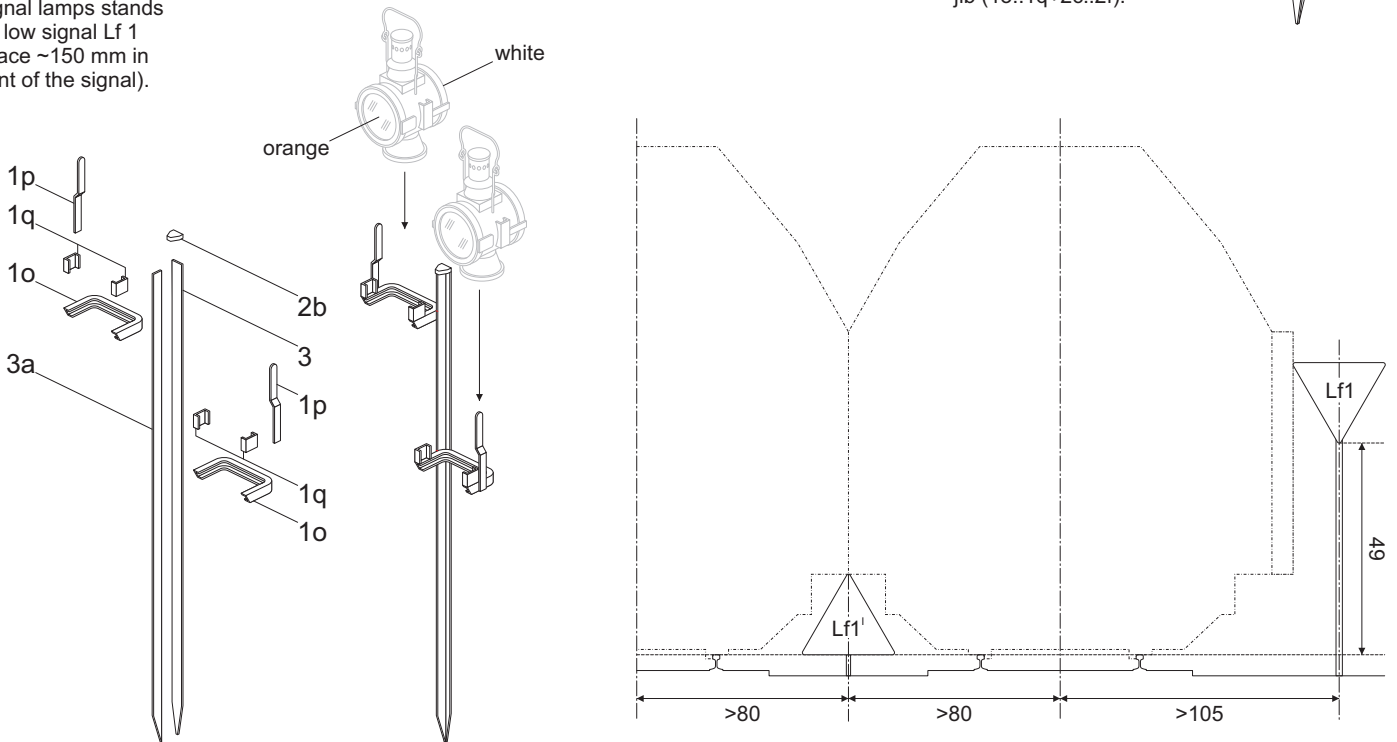

Railway signals and indicators DRG/DR, 1935-1945, scale 1:25

Assembly manual 2/10

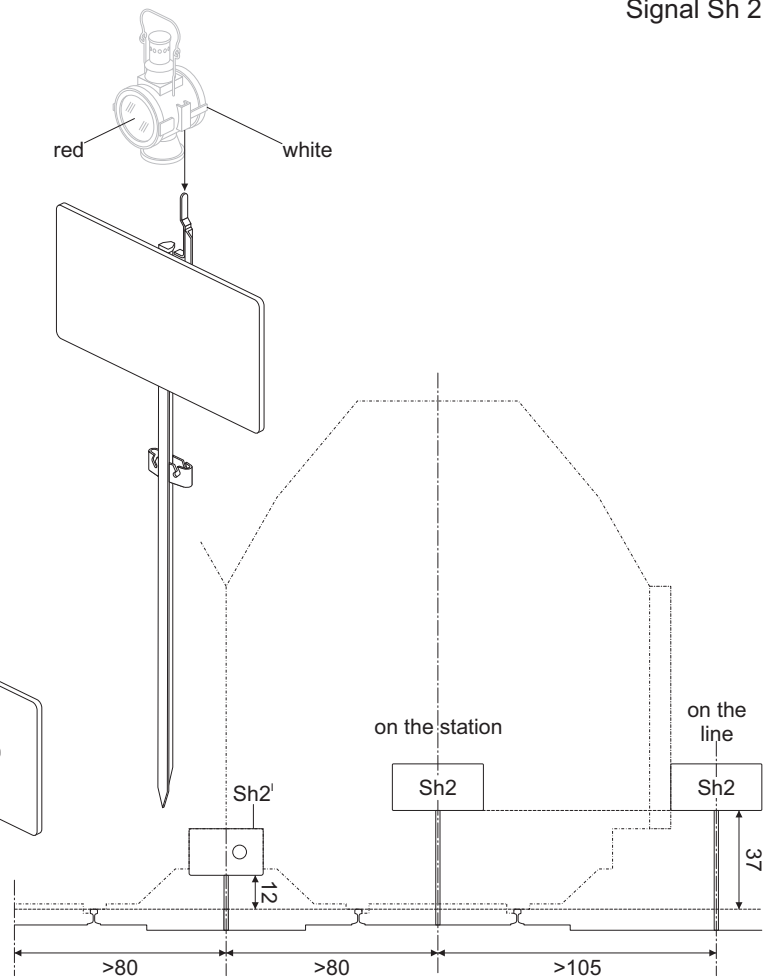
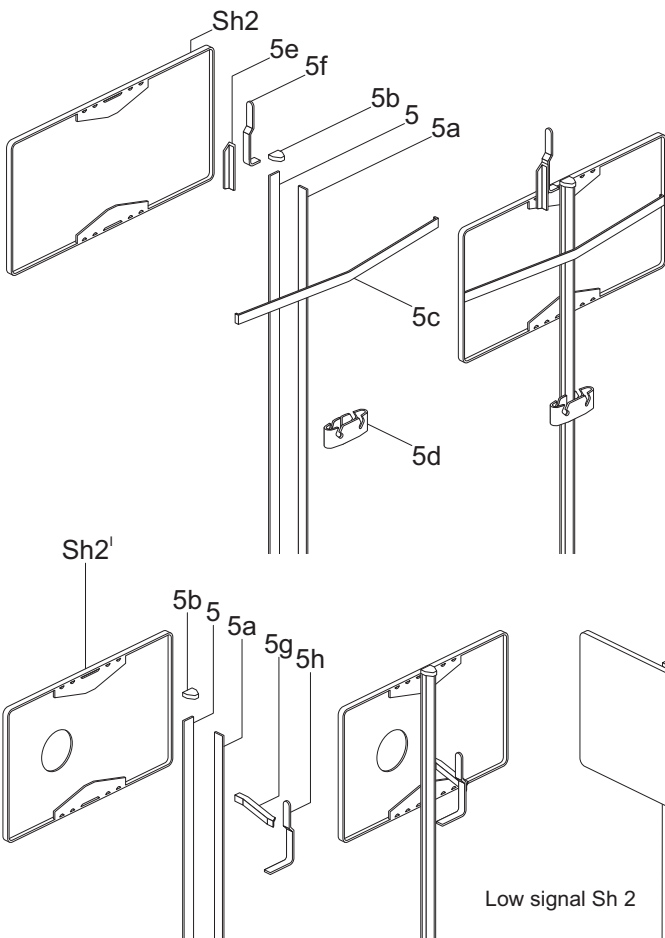
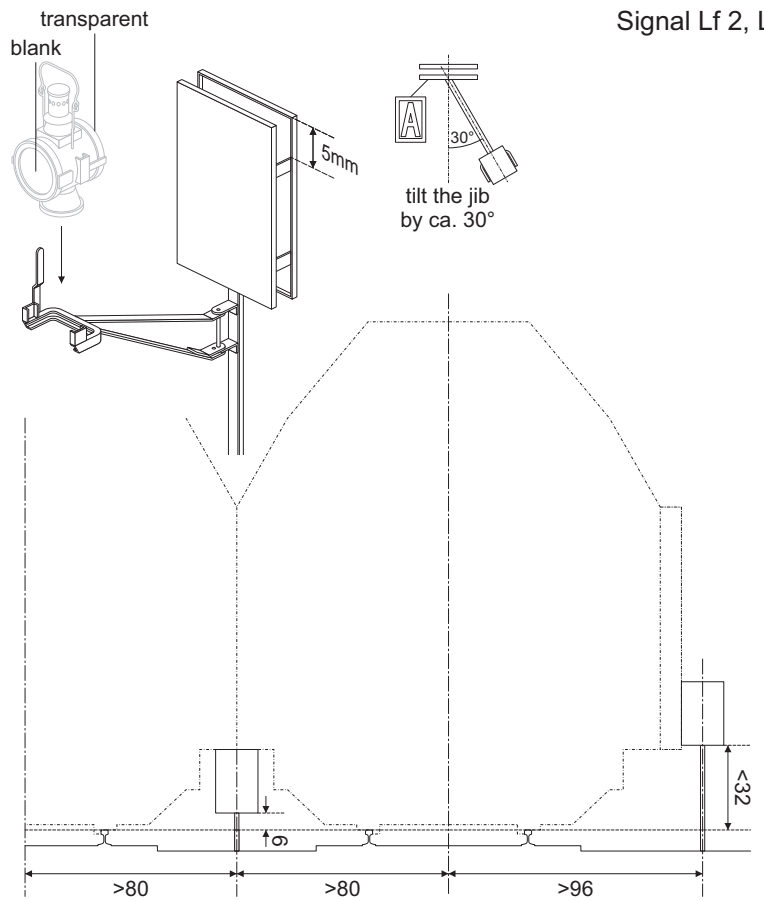
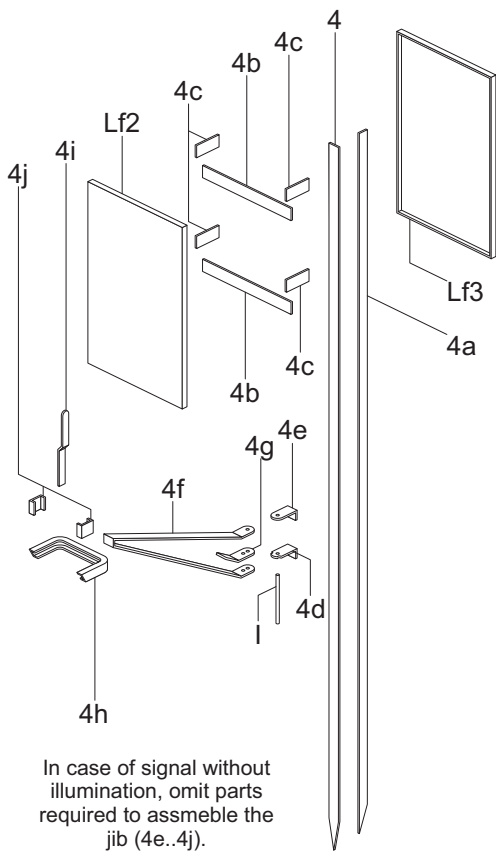

Railway signals and indicators DRG/DR, 1935-1945, scale 1:25

Assembly manual 3/10

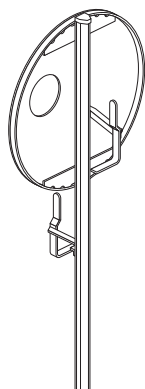
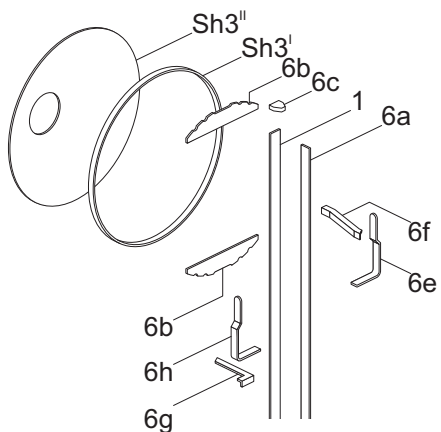
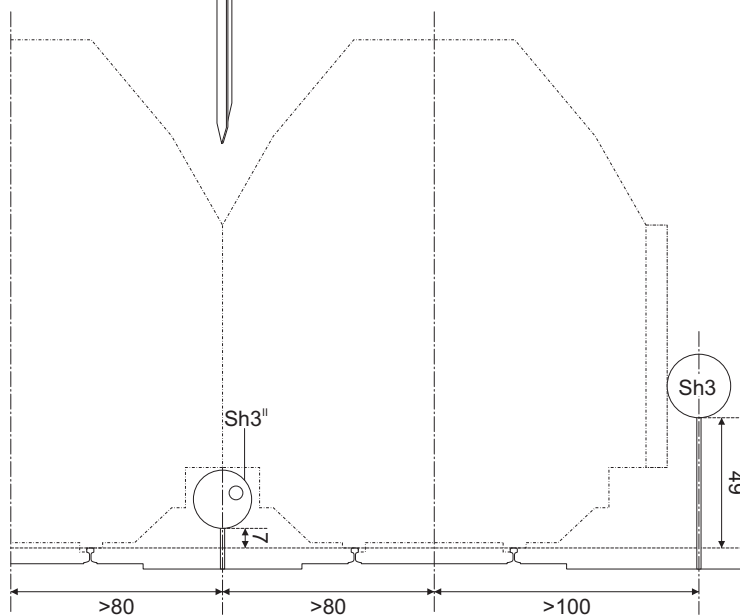
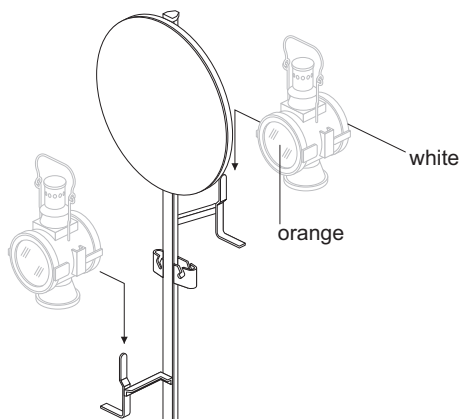
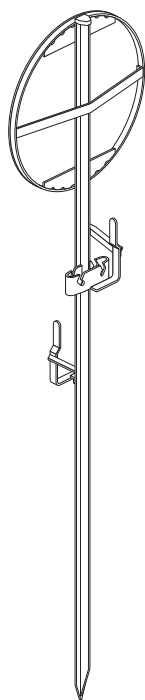
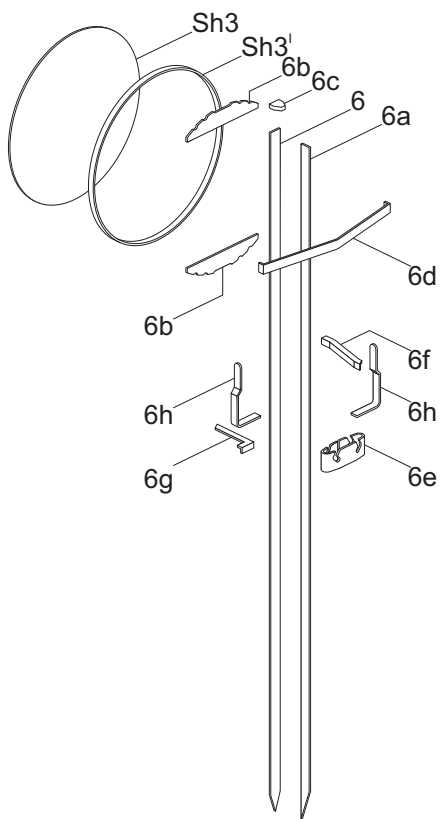

Low signal Sh 3

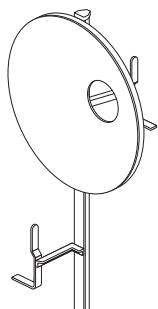

Support for signals
Lf 1, Sh 2, Sh 3
(alternative)

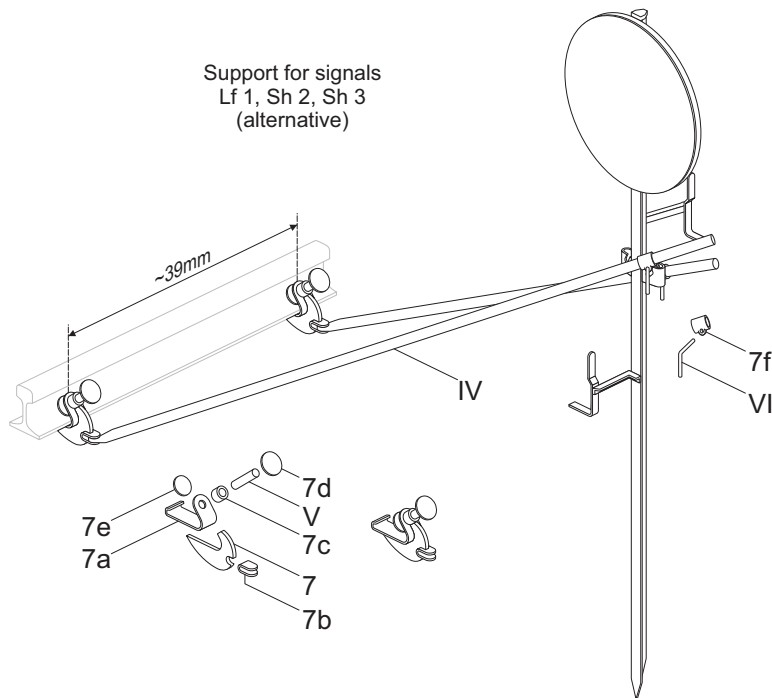

Railway signals and indicators DRG/DR, 1935-1945, scale 1:25

Assembly manual 4/10

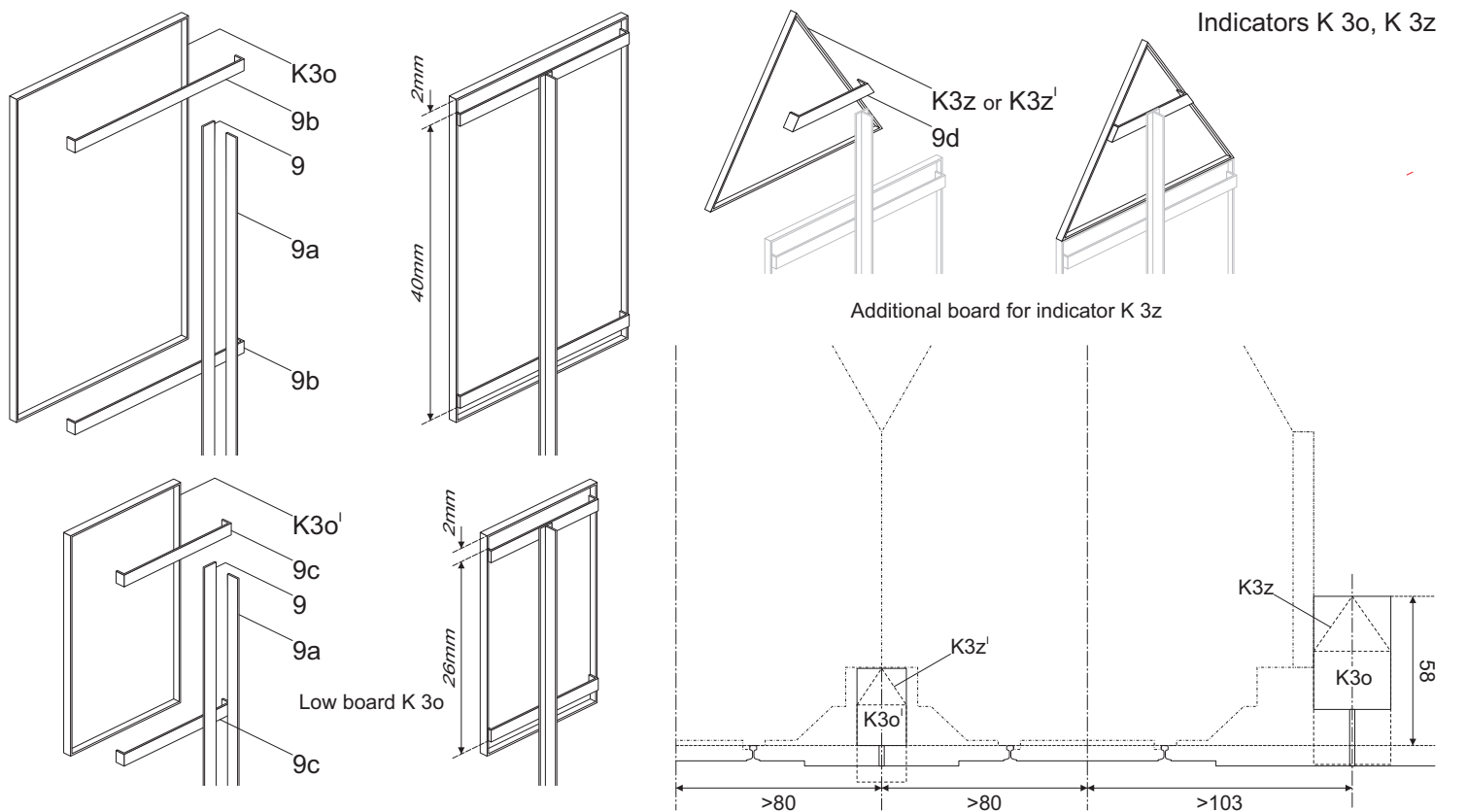
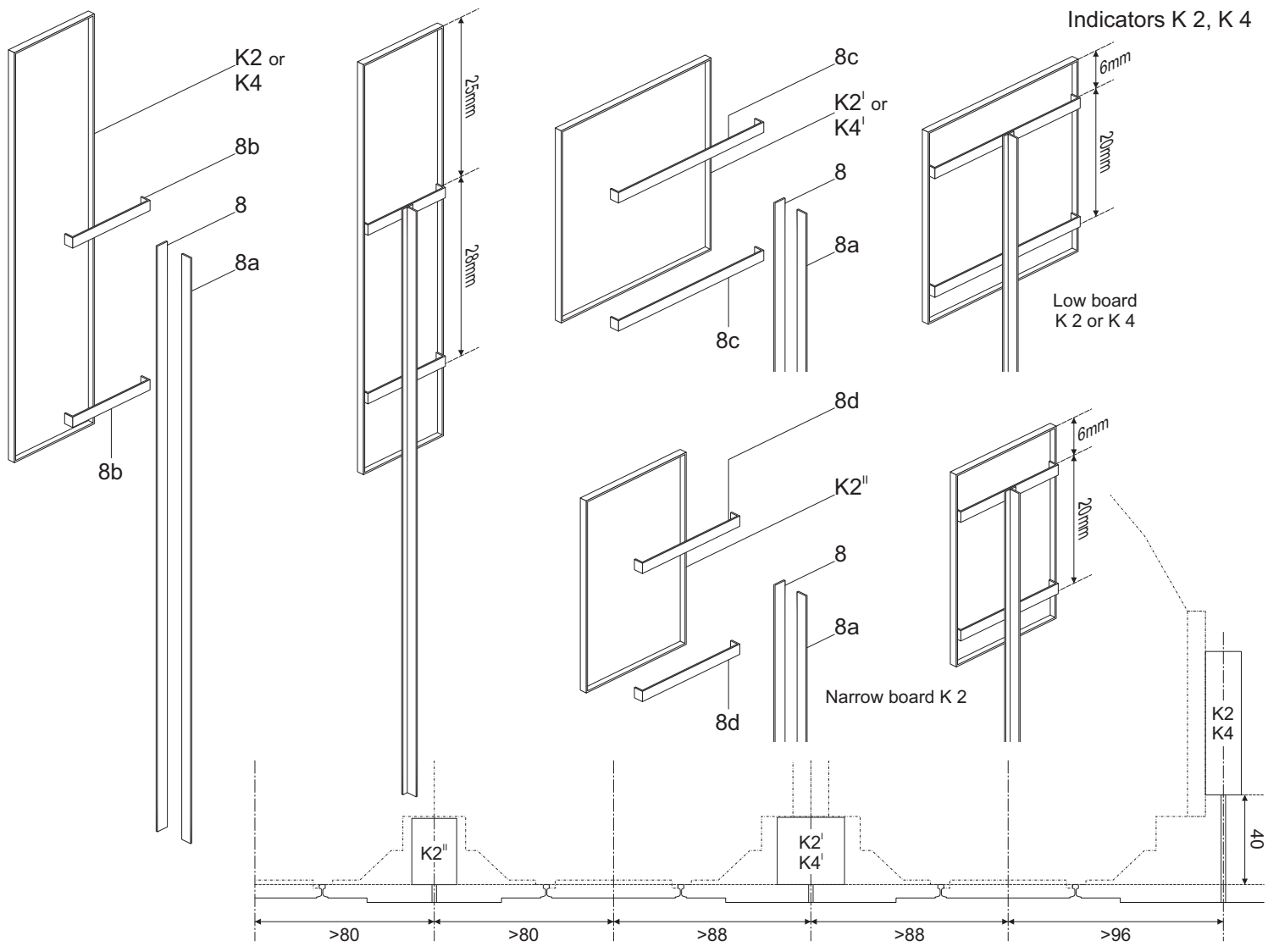

Railway signals and indicators DRG/DR, 1935-1945, scale 1:25

Assembly manual 5/10

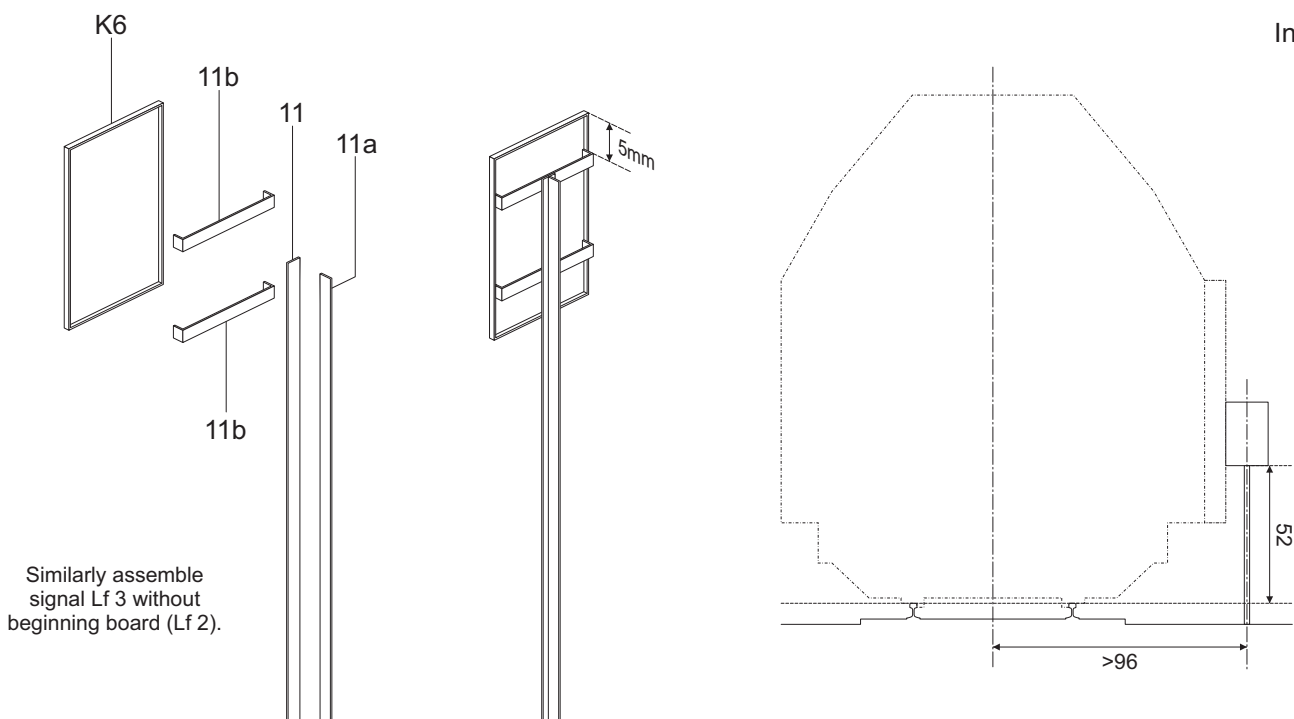
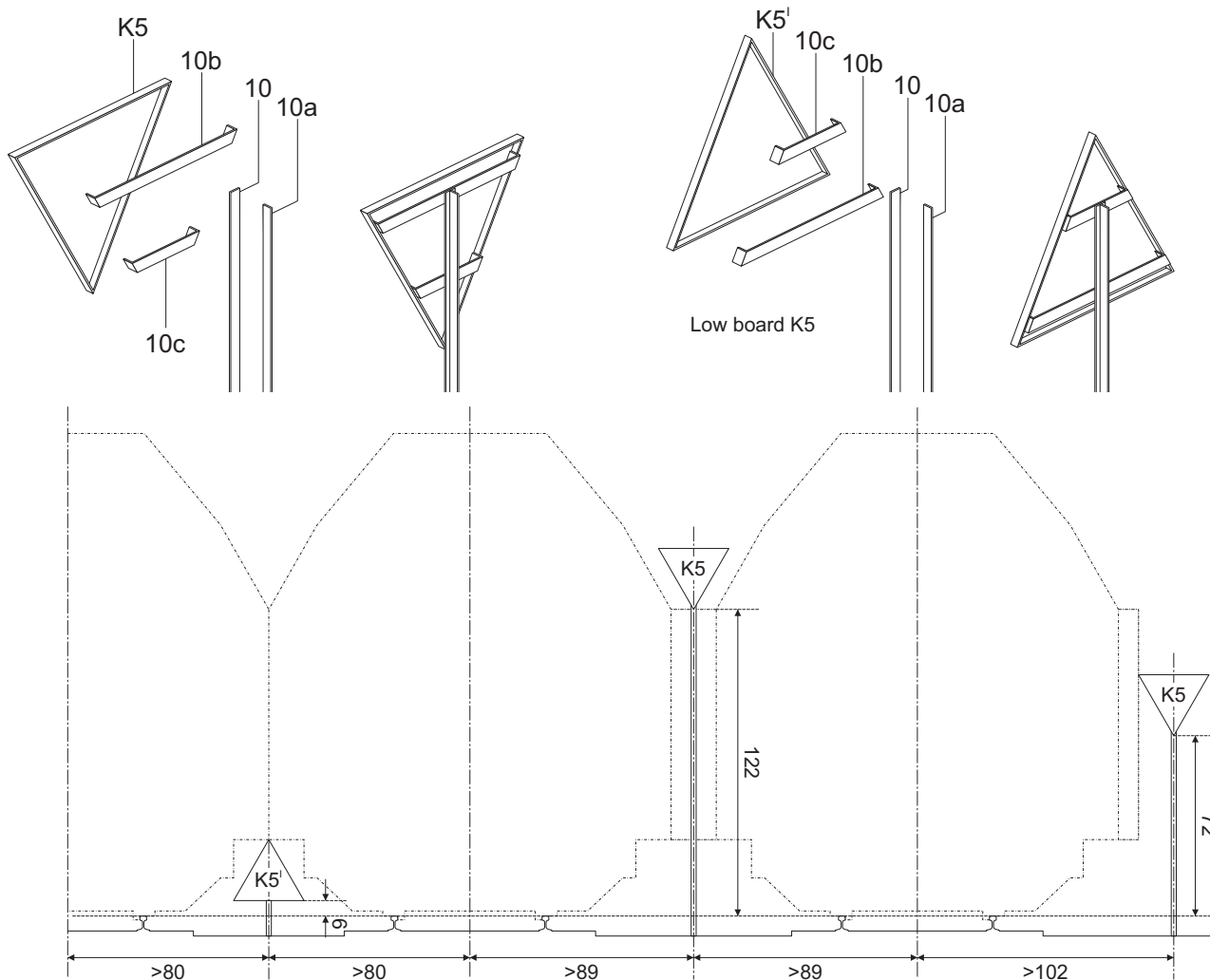

Railway signals and indicators DRG/DR, 1935-1945, scale 1:25

Assembly manual 6/10

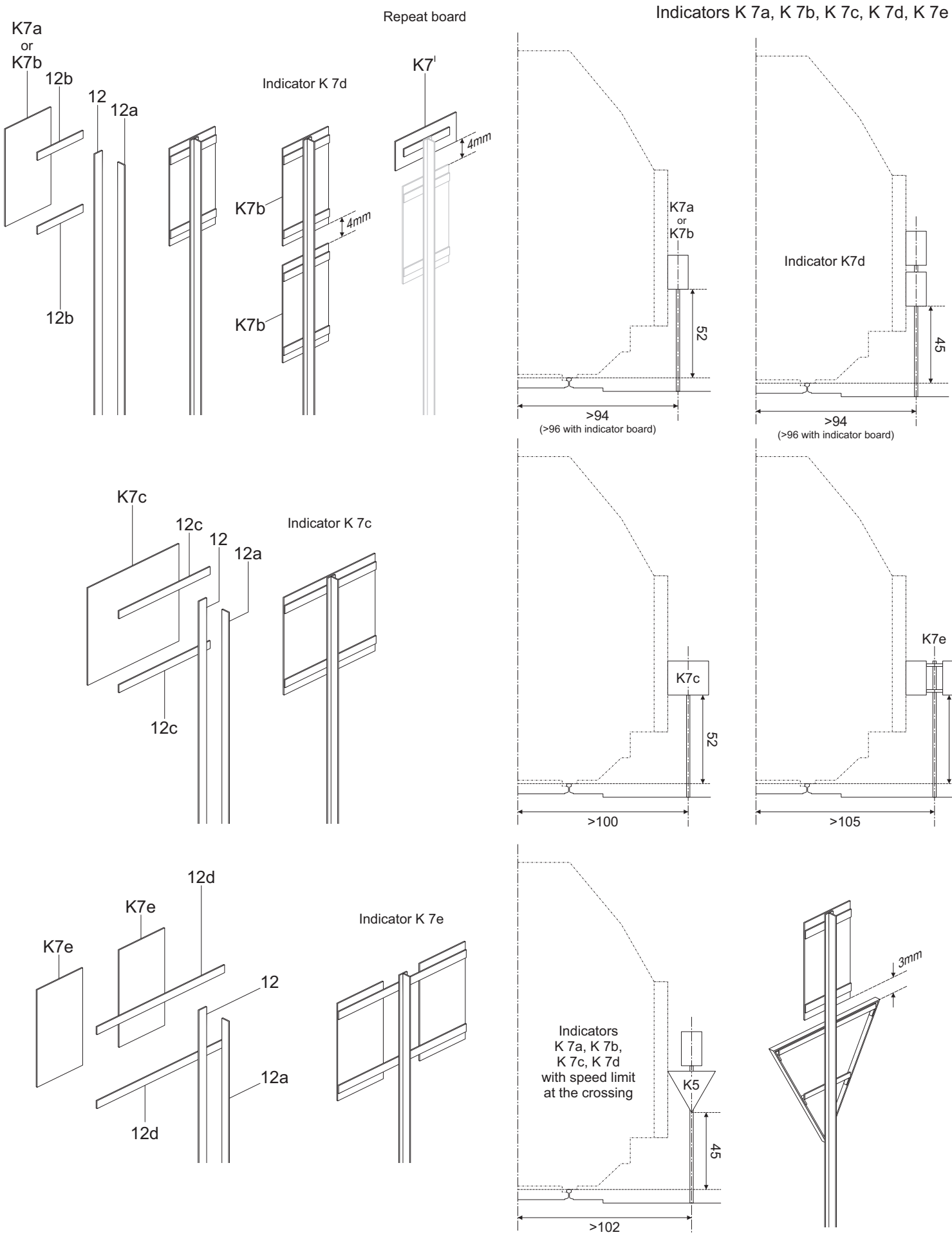

Railway signals and indicators DRG/DR, 1935-1945, scale 1:25

Assembly manual 7/10

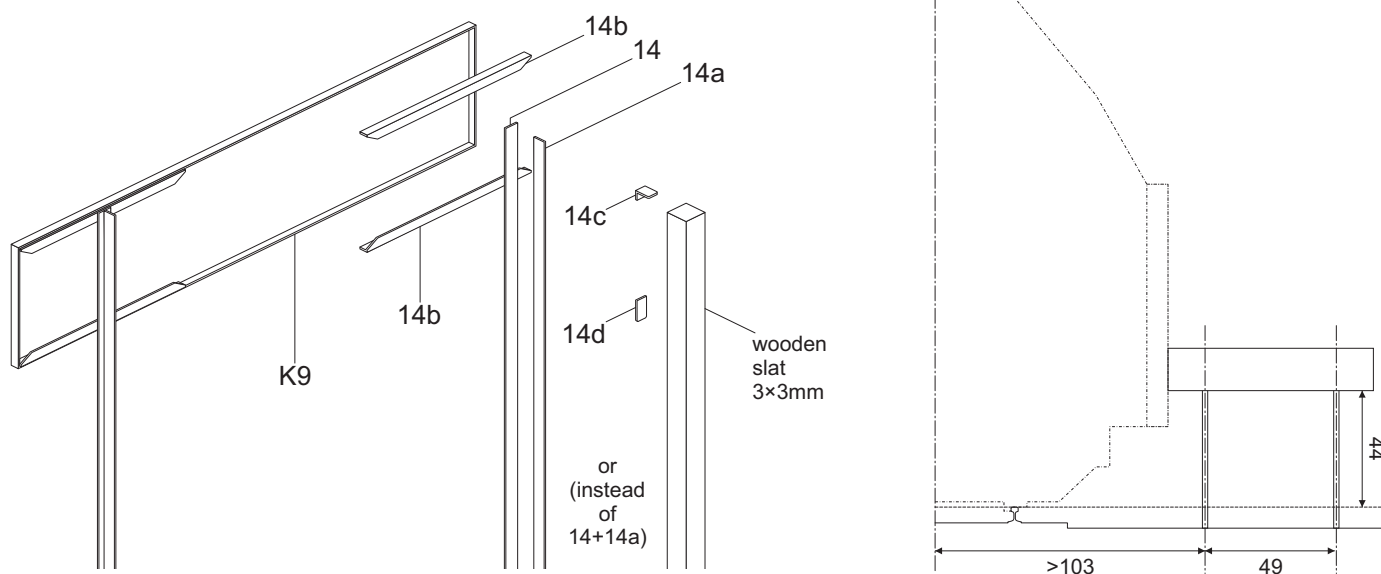
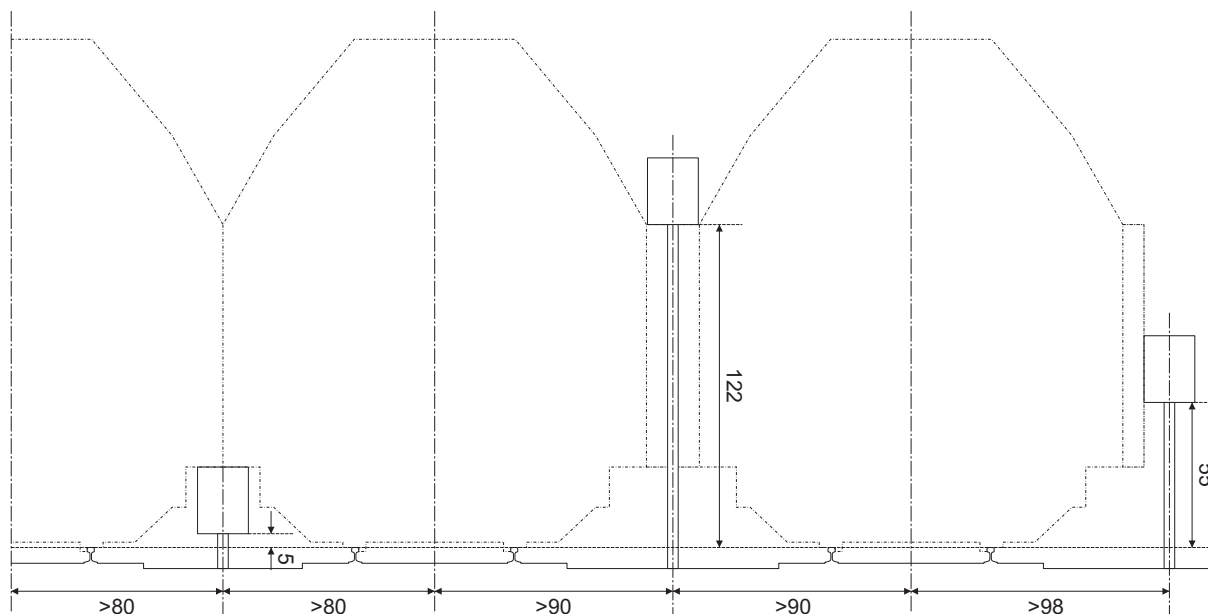
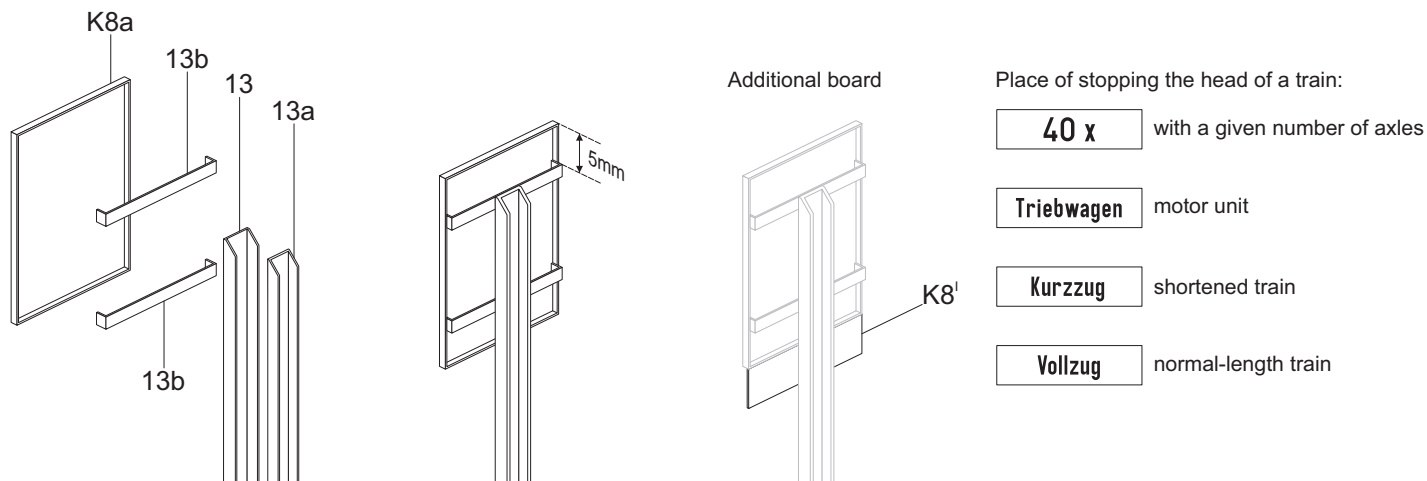

Railway signals and indicators DRG/DR, 1935-1945, scale 1:25

Assembly manual 8/10

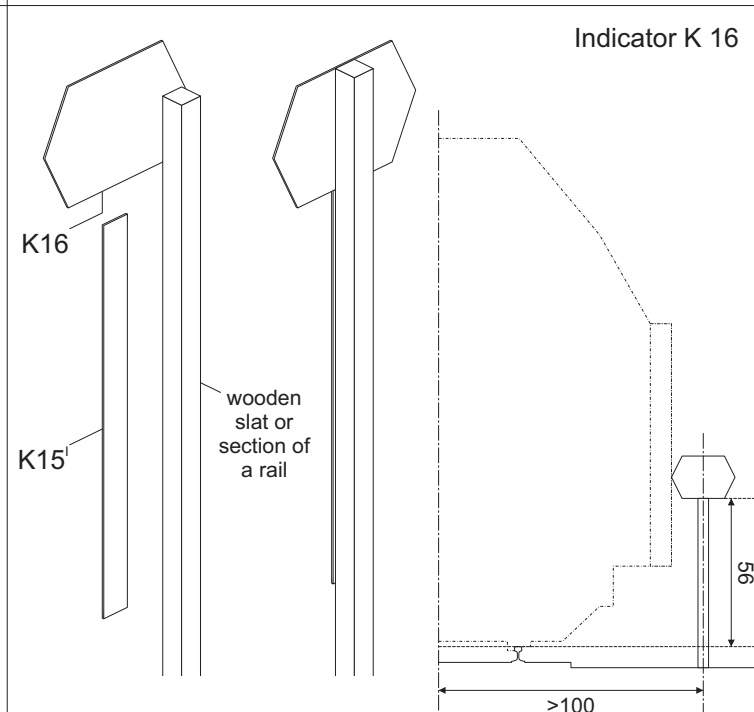
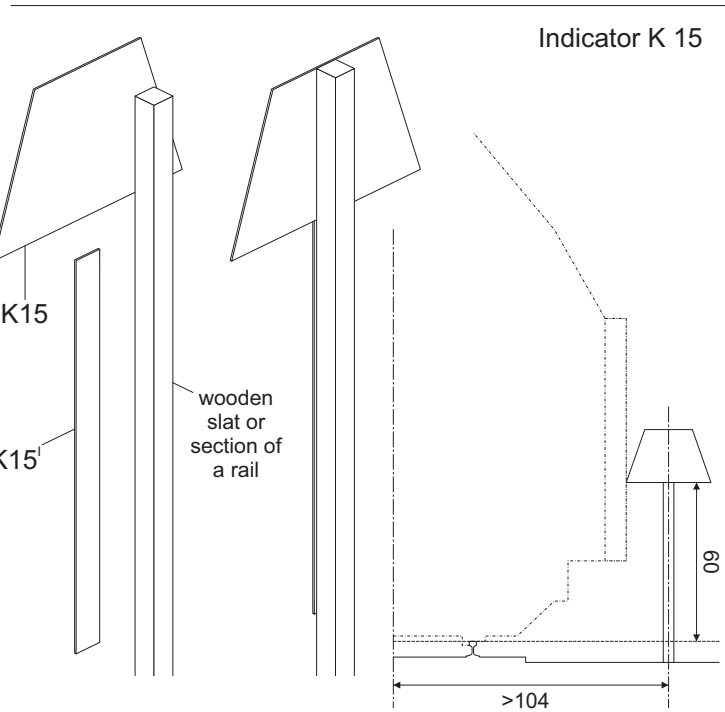
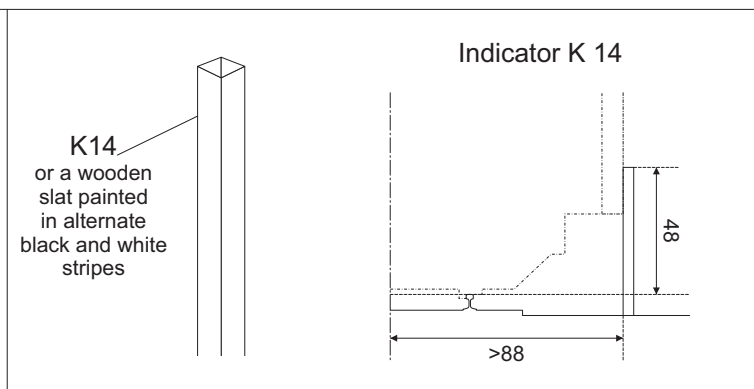
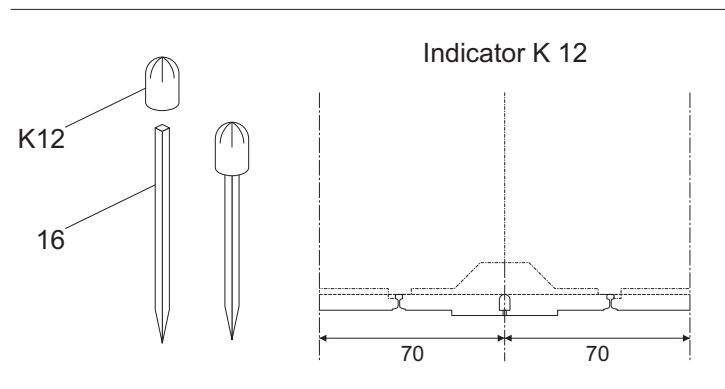
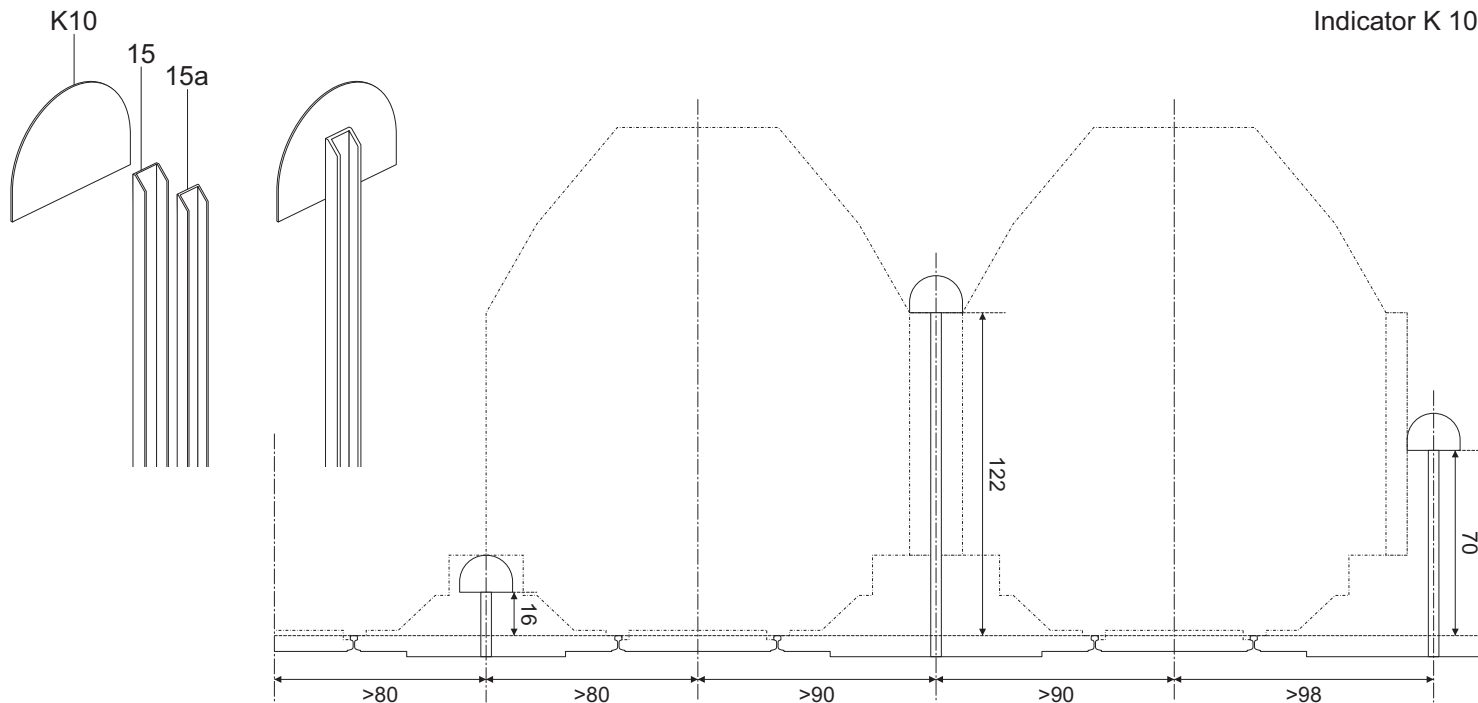

Alternative: skip part K15' and paint front of the post in alternate, slanted black and white stripes

Alternative: skip part K15' and paint front of the post in alternate, slanted black and white stripes

Railway signals and indicators DRG/DR, 1935-1945, scale 1:25

Assembly manual 9/10

Indicator K 17

"M" plate

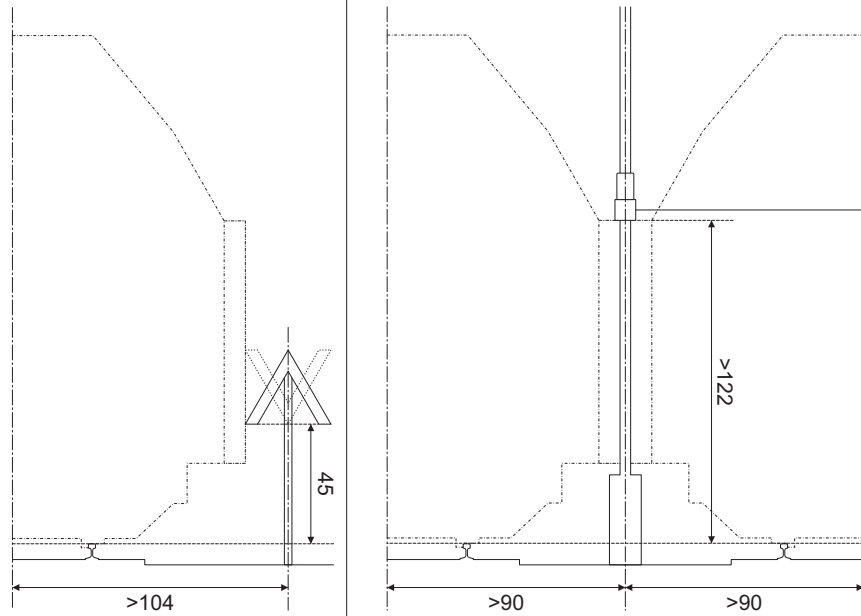
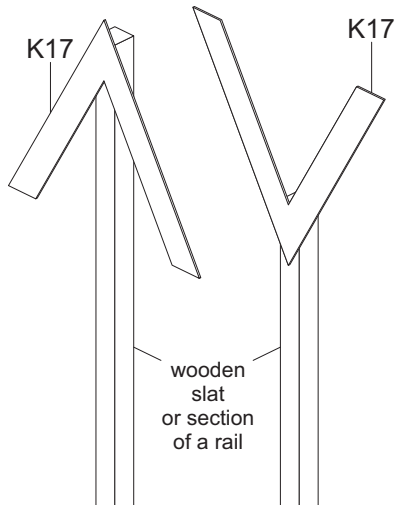

Mt
(place under the plate with signal identifier)

Signals for electrified rail lines EI 1-EI 6, K 8b

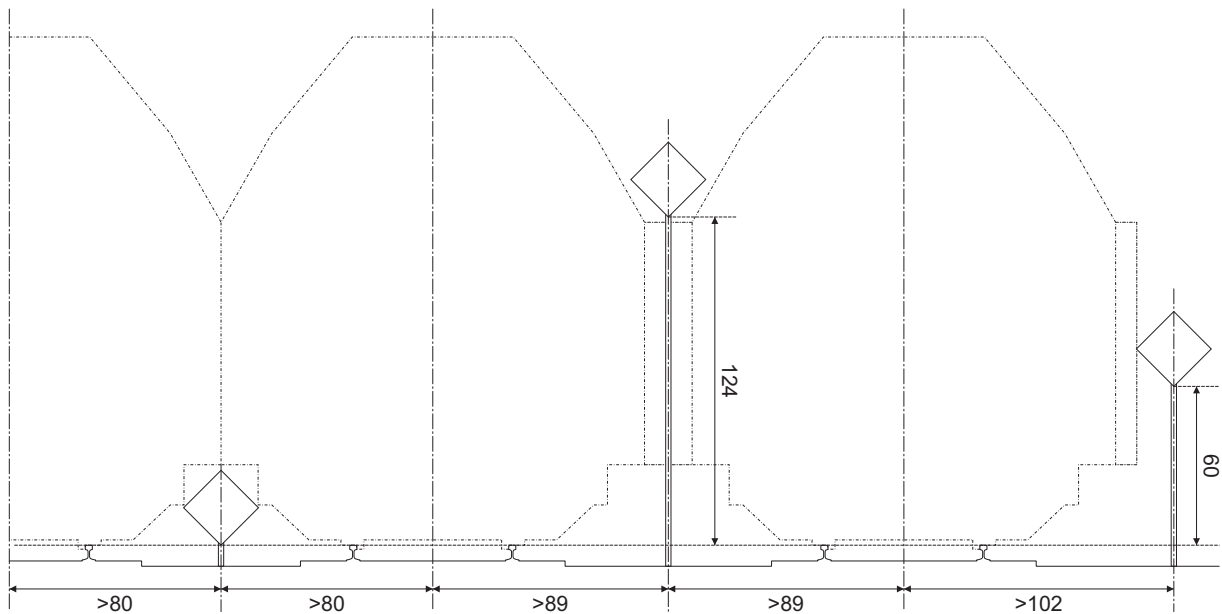
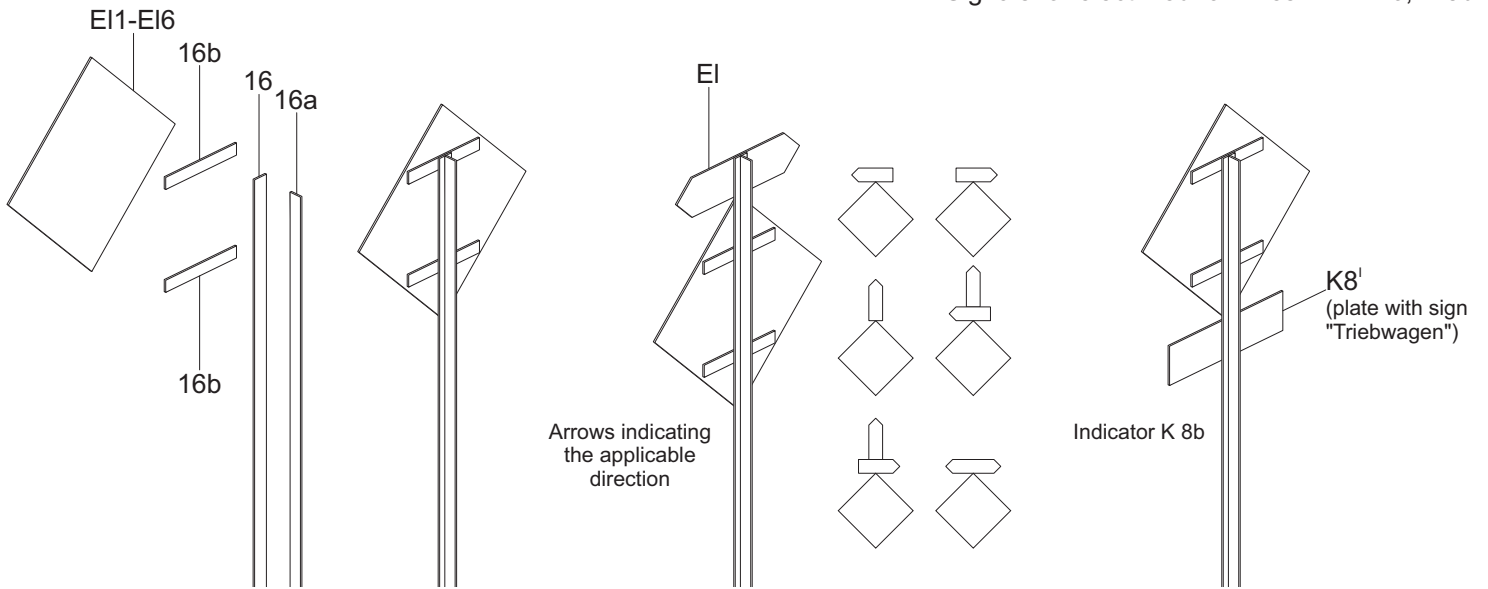

Railway signals and indicators DRG/DR, 1935-1945, scale 1:25

Assembly manual 10/10