

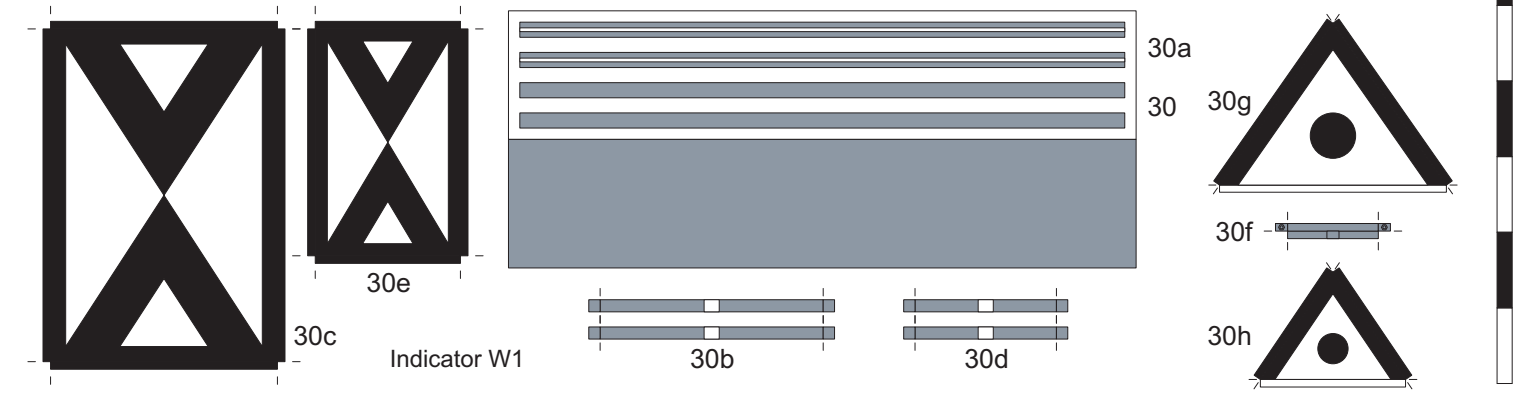

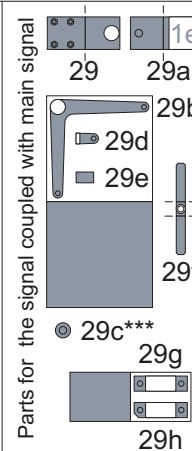

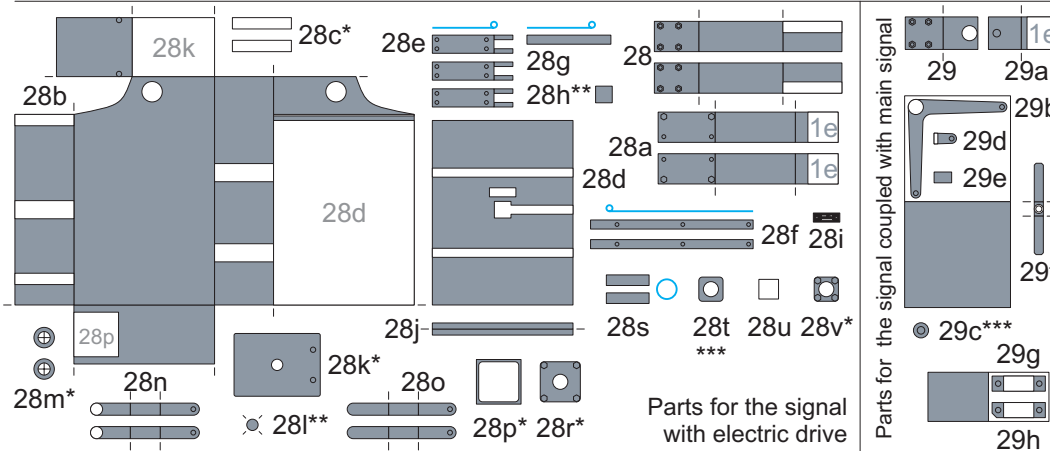

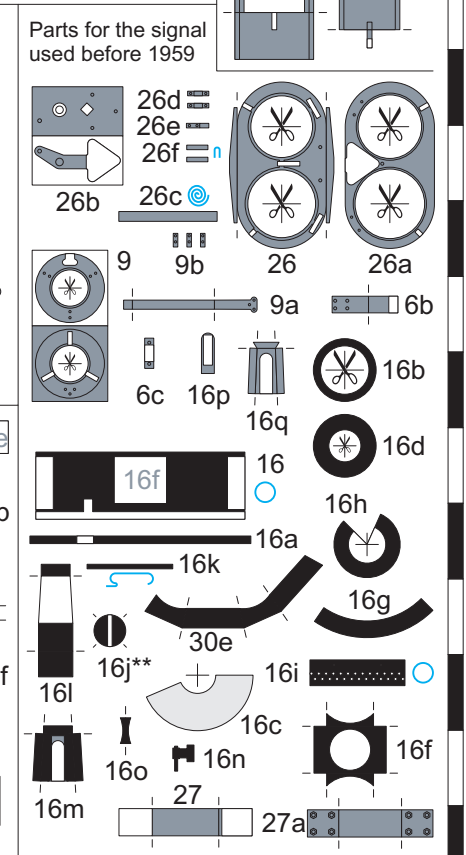

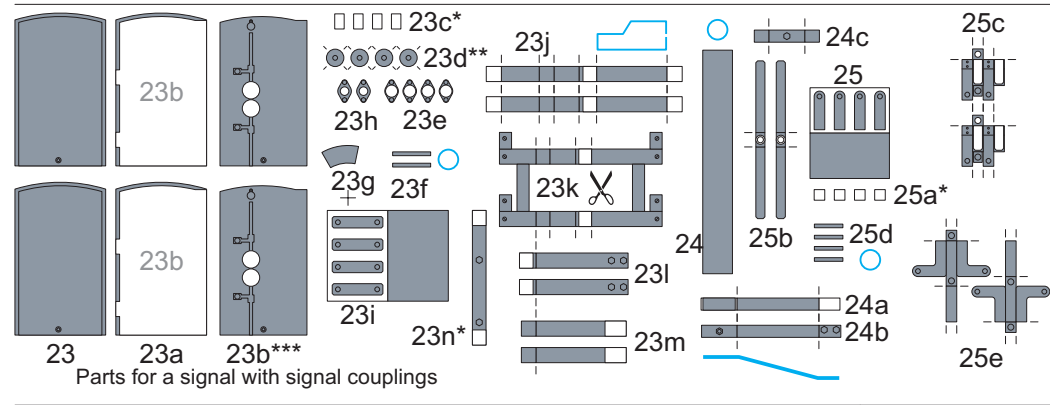
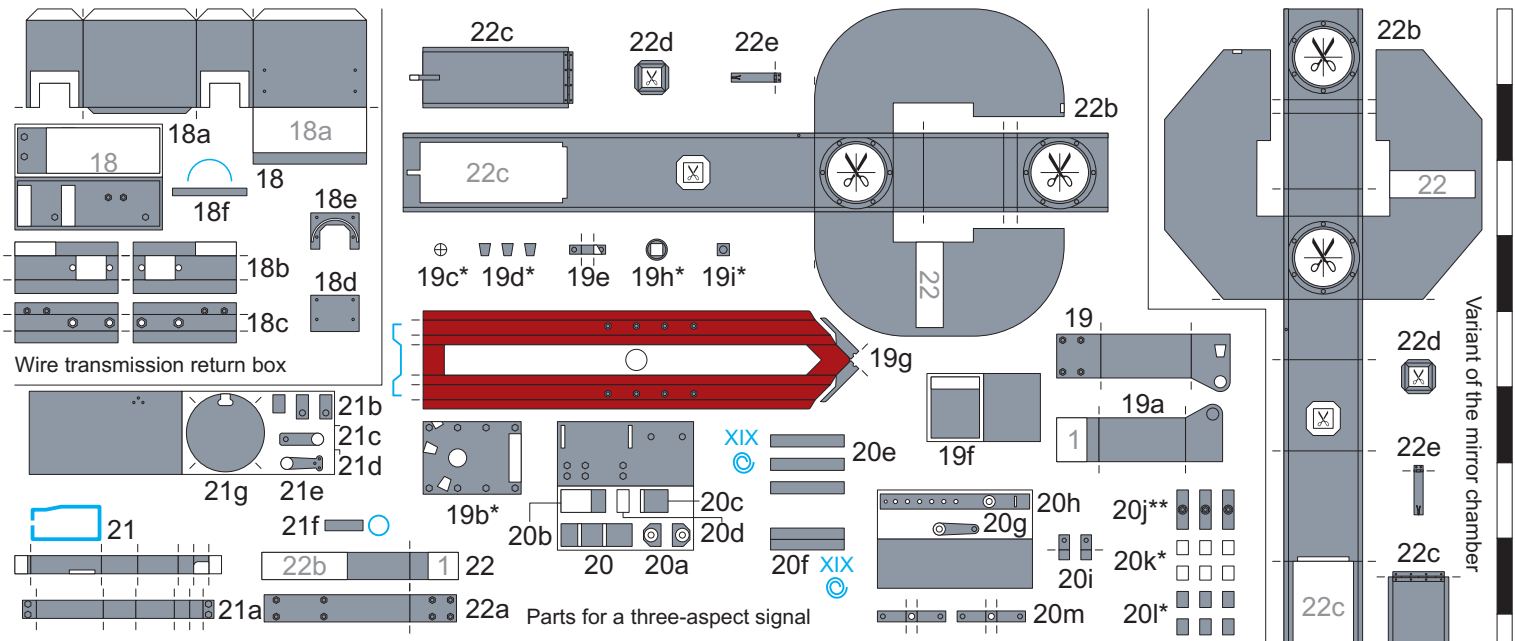















# Mechanical distant signal, scale 1:25



# Mechanical distant signal, scale 1:25

- Templates**
-  I (wire)
  -  II (wire)
  -  III (wire)
  -  IV (orange film)
  -  V (green film)
  -  VI (wire)
  -  VII (wire)
  -  VIII (wire)
  -  IX (wire)
  -  X (wire)
  -  XI (wire)
  -  XII (wire)
  -  XIII (white film)
  -  XIV (clear film)
  -  XV (white film)
  -  XVI (wire)
  -  XVII (wire)
  -  XVIII (wire)
  -  XIX (wire)
  -  XX (wire)
  -  XXI (wire)
  -  XXII (clear film)
  -  XXIII (green film)
  -  XXIV (white film)

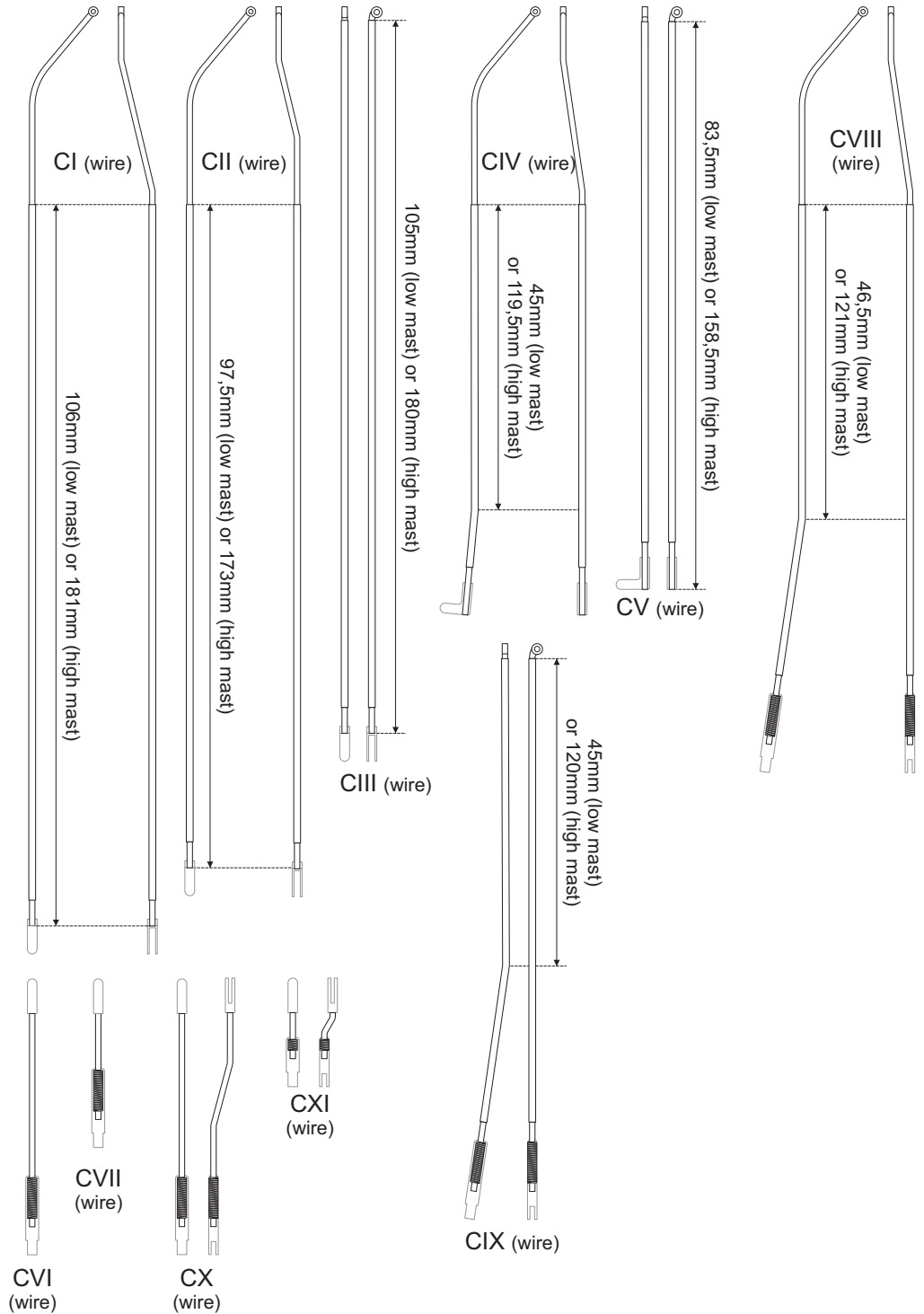

# Mechanical distant signal, scale 1:25

1cm



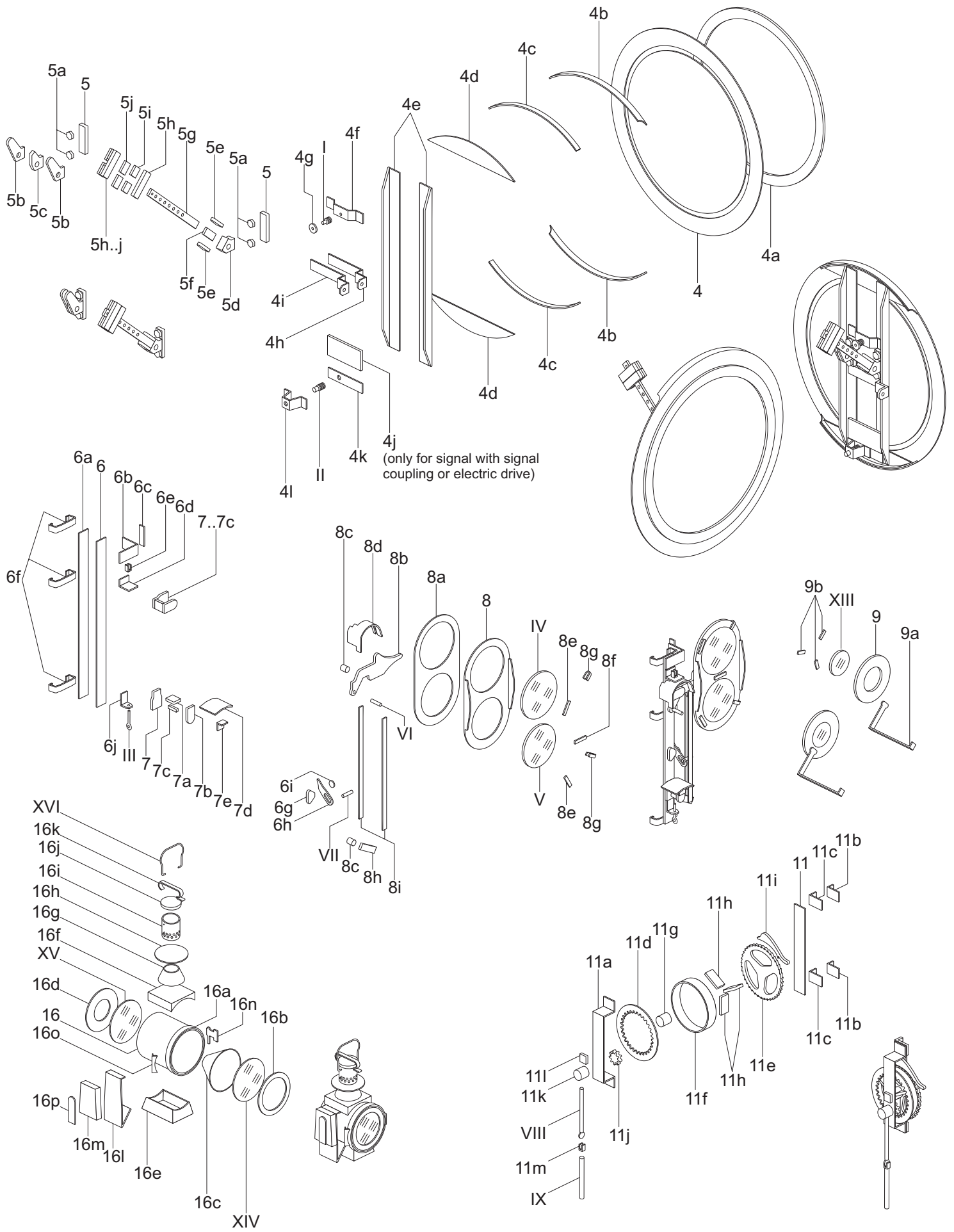

# Mechanical distant signal, scale 1:25

Assembly manual 2/8



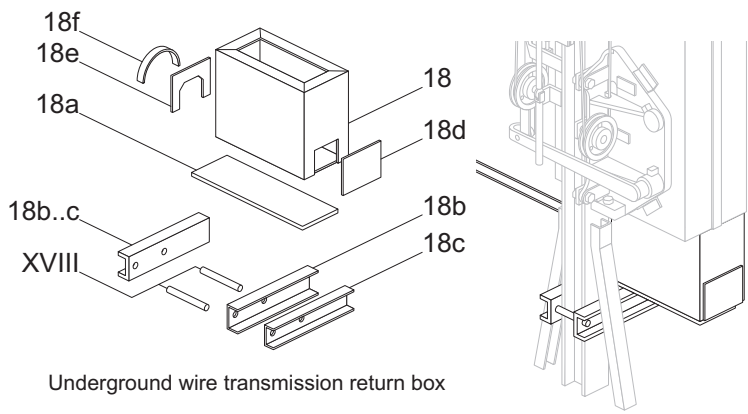

Underground wire transmission return box

Parts of the three-aspect signal

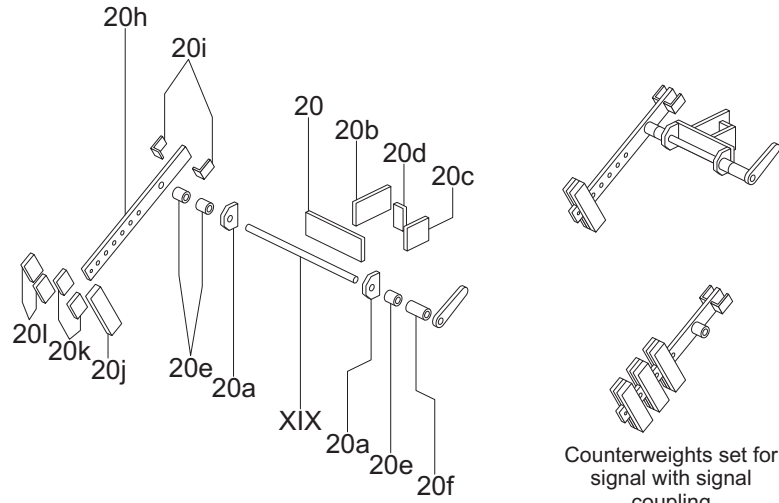

Counterweights set for signal with signal coupling

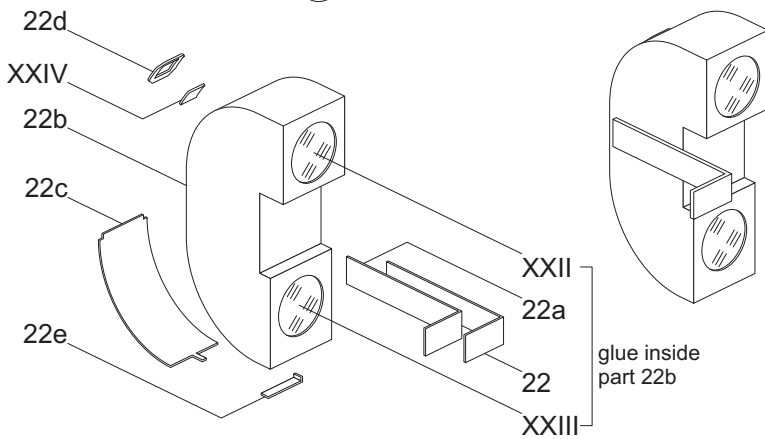
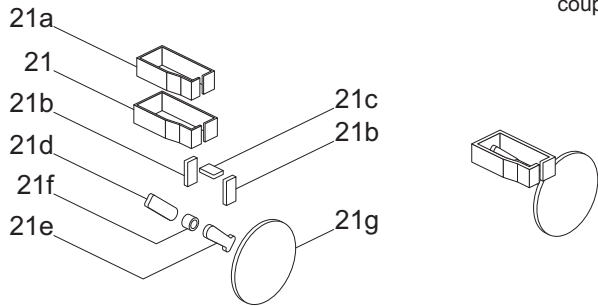

Disk holder on a two-aspect signal with moving arrow.

In this version skip parts 10..10m, and do not put green lens in the upper shutter (part V).

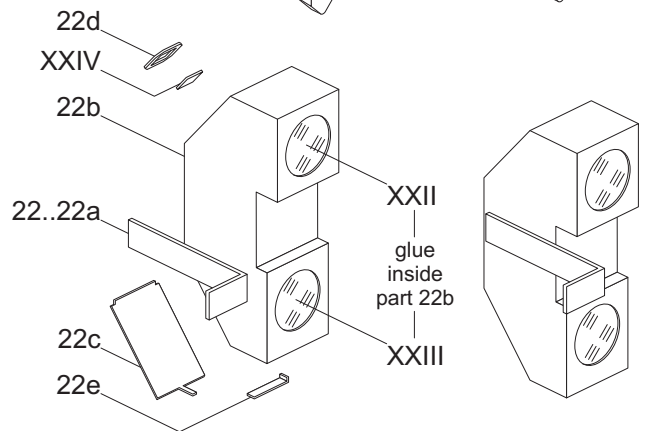
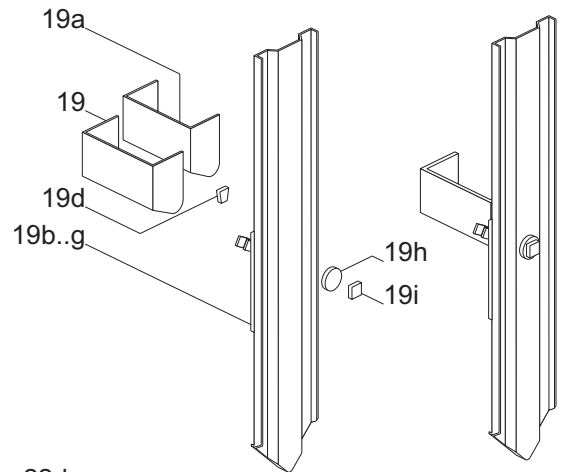
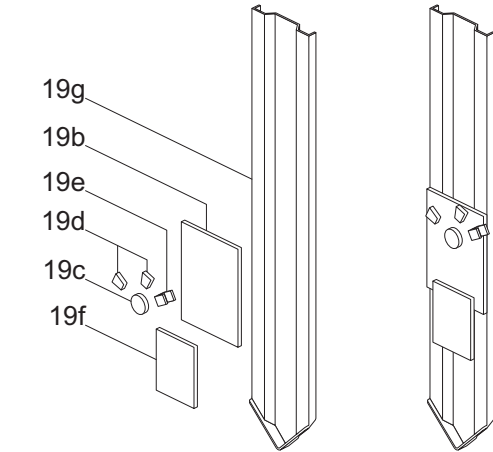
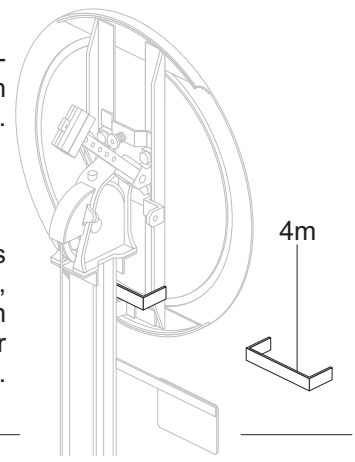

Variant of the mirror chamber

# Mechanical distant signal, scale 1:25

Assembly manual 4/8

### Three-aspect distant signal

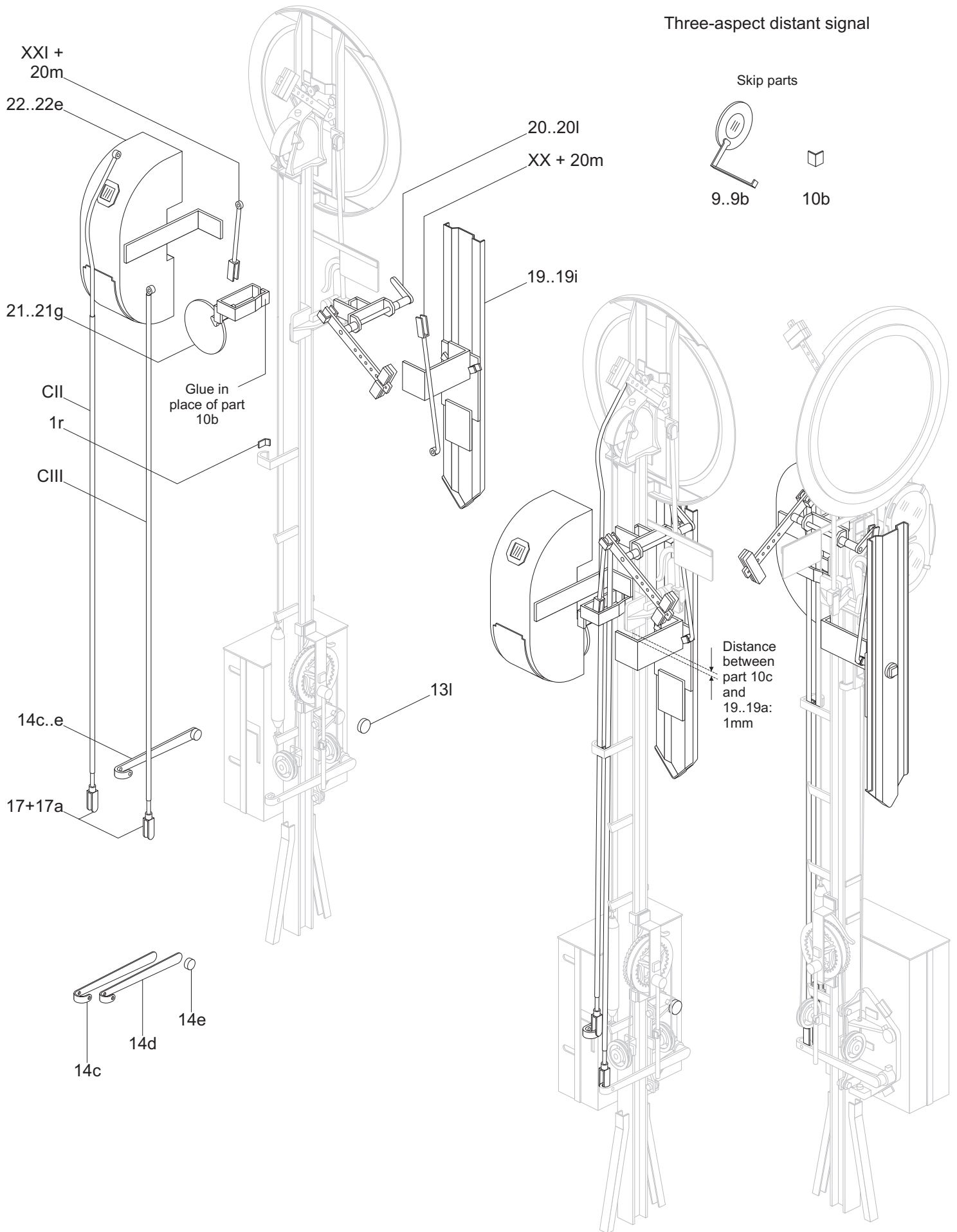

## Mechanical distant signal, scale 1:25

Assembly manual 5/8



Signal couplings

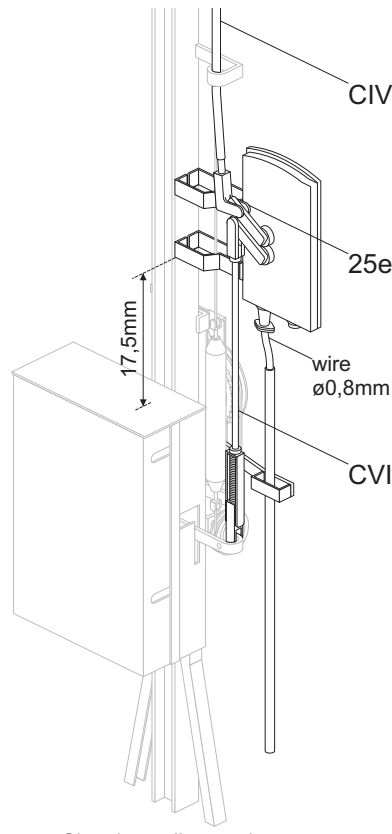
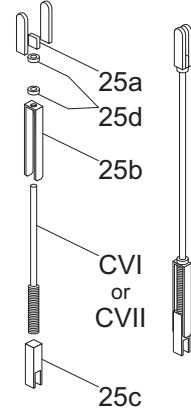
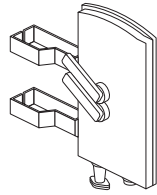
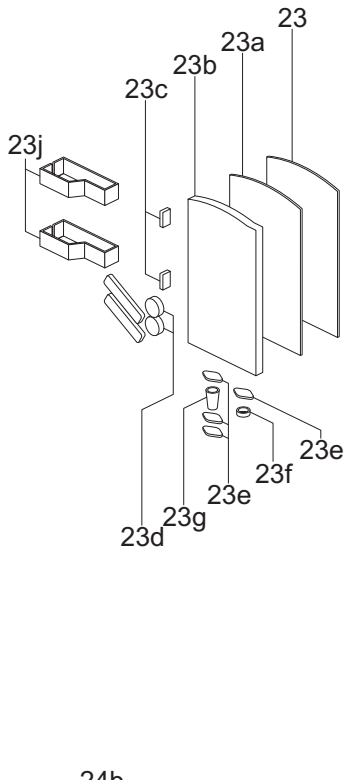

Signal coupling on the two-aspect signal

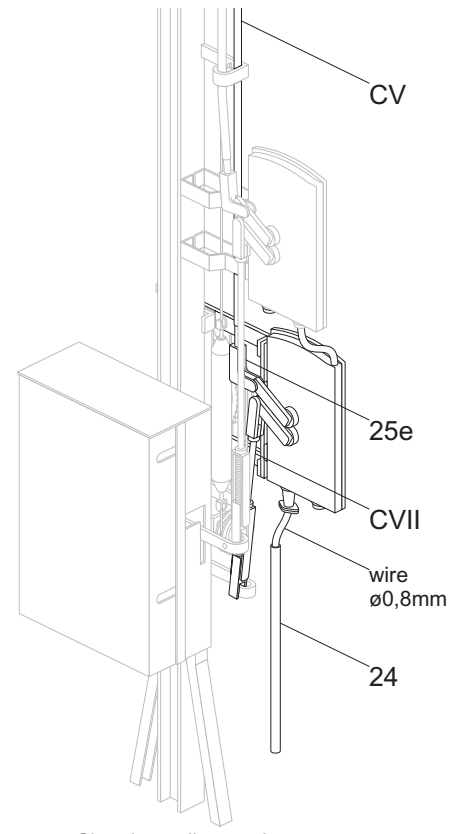

Signal coupling on the three-aspect signal

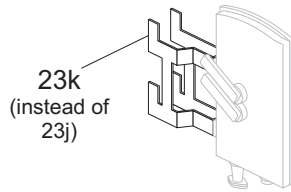
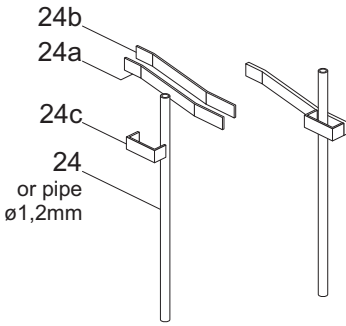

Holder of the upper coupling on the high mast of the signal

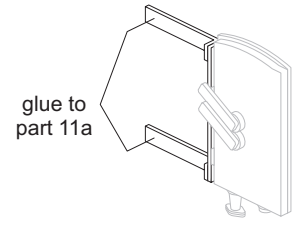
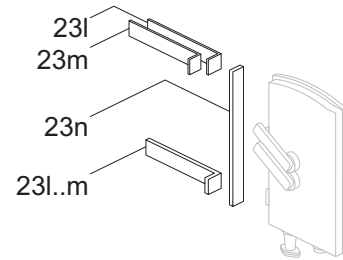

Holder of the lower coupling

Distant signal coupled with the main signal drive

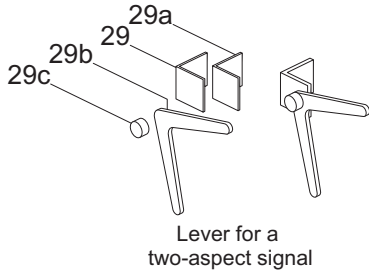

Lever for a two-aspect signal

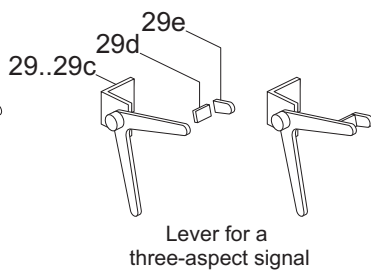

Lever for a three-aspect signal

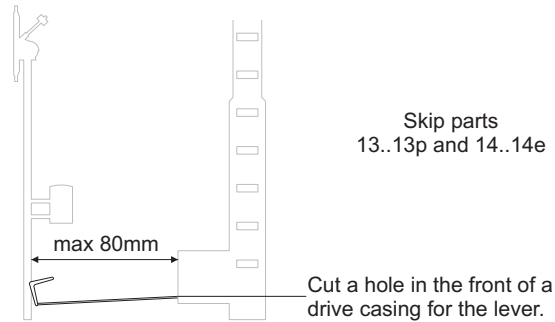

Skip parts 13..13p and 14..14e

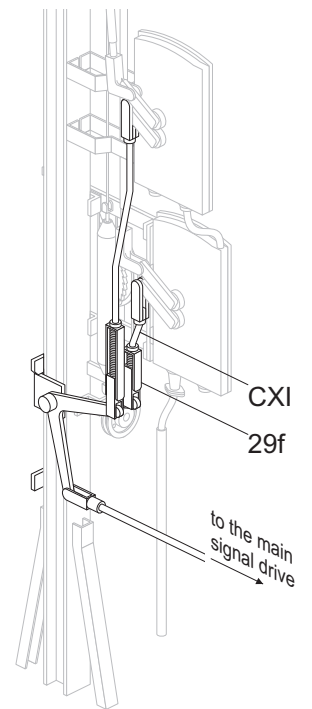
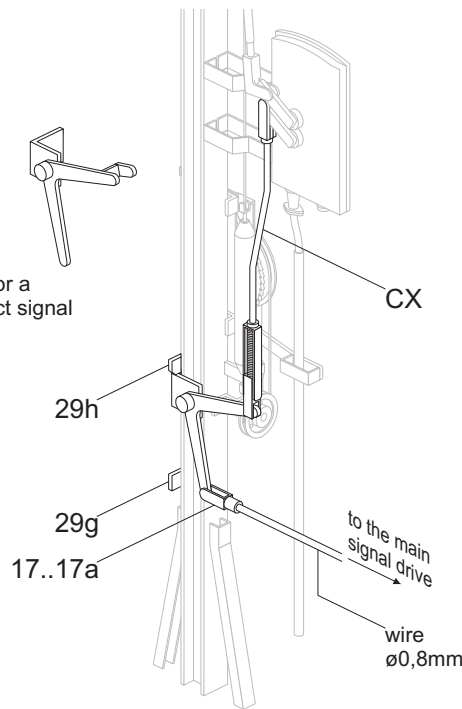

# Mechanical distant signal, scale 1:25

## Assembly manual 6/8

Electric drive

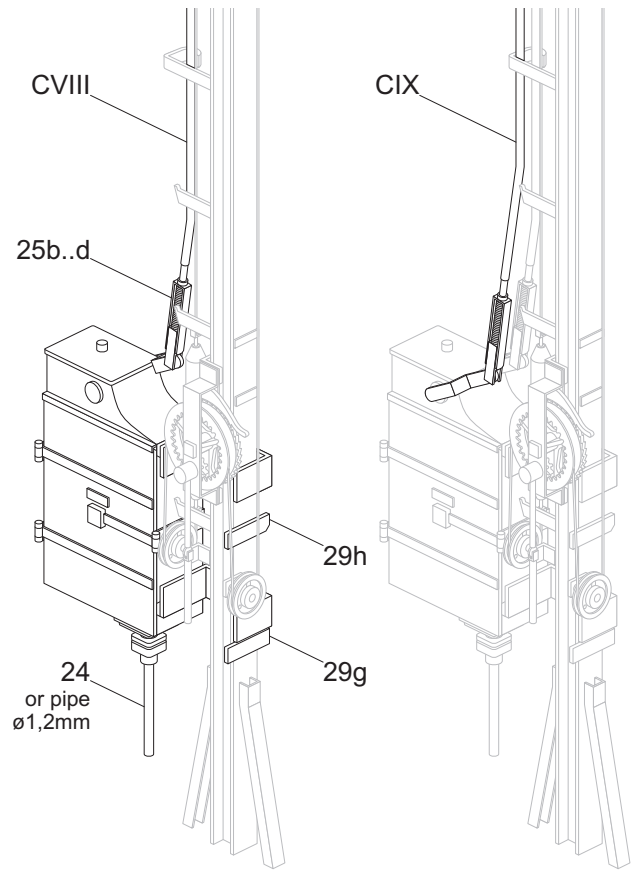
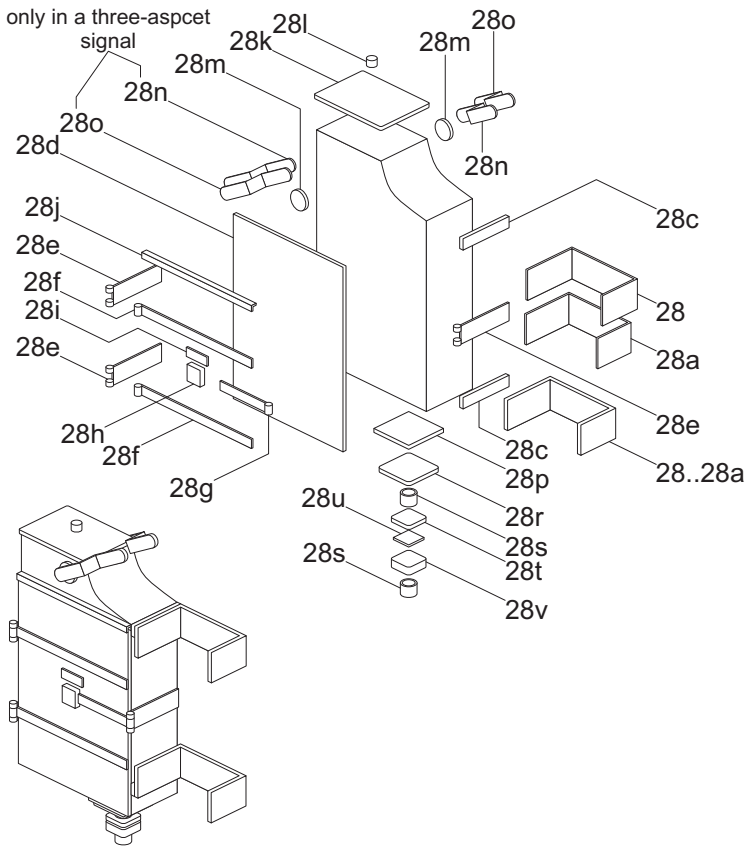

Electric drive in a two-aspect signal

Electric drive in a three-aspect signal

Parts for the signal used before 1959

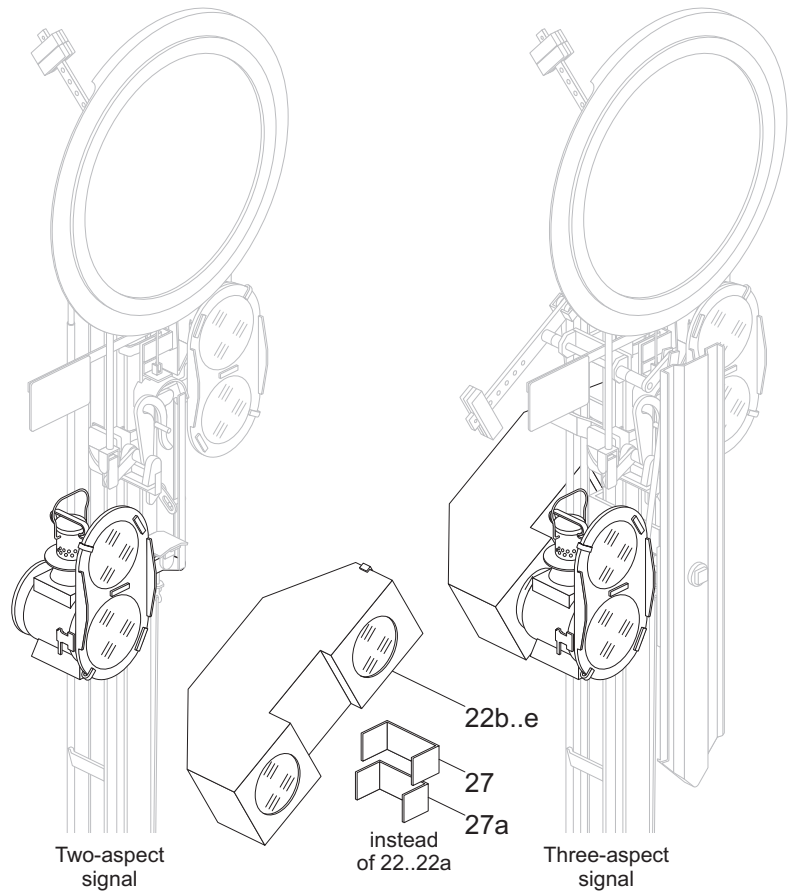
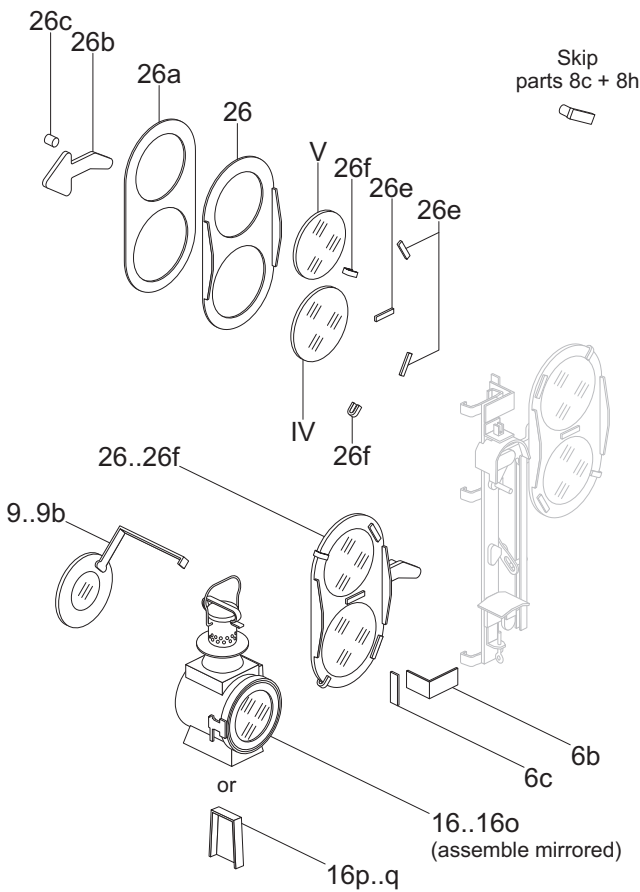

Two-aspect signal

Three-aspect signal

# Mechanical distant signal, scale 1:25

Assembly manual 7/8

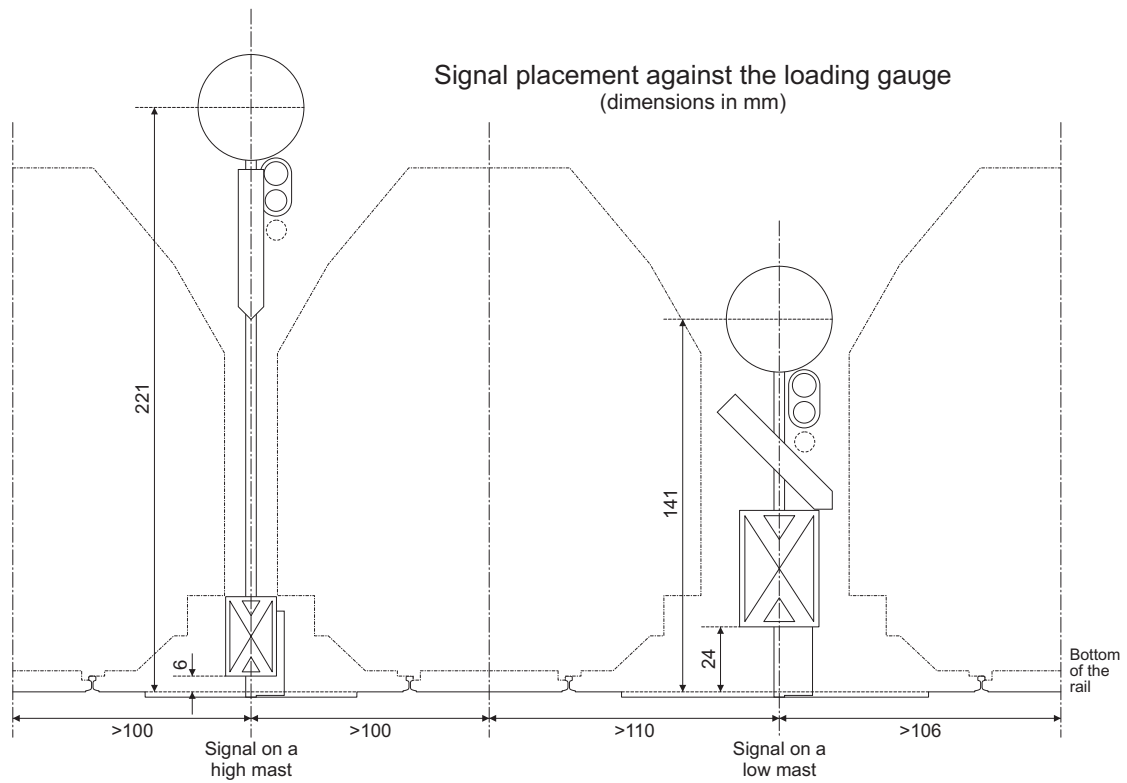
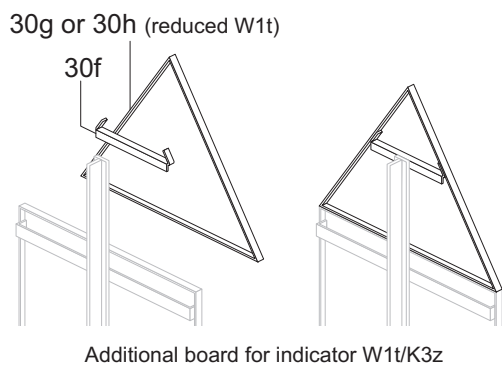
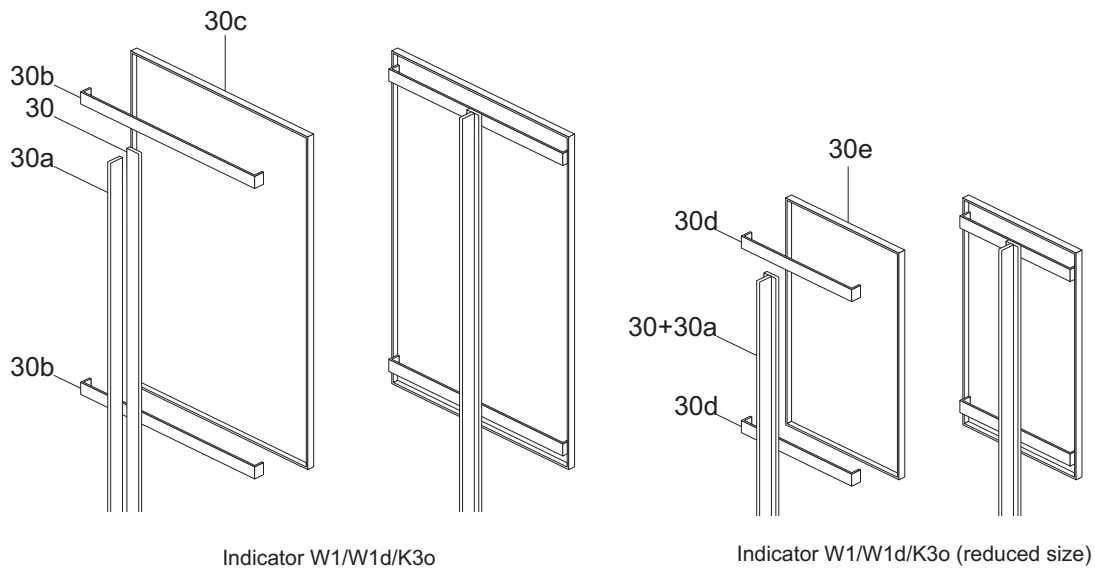

# Mechanical distant signal, scale 1:25

Assembly manual 8/8