

Signale und Kennzeichen der DRG/DR, 1935-1945, 1:120 (TT)

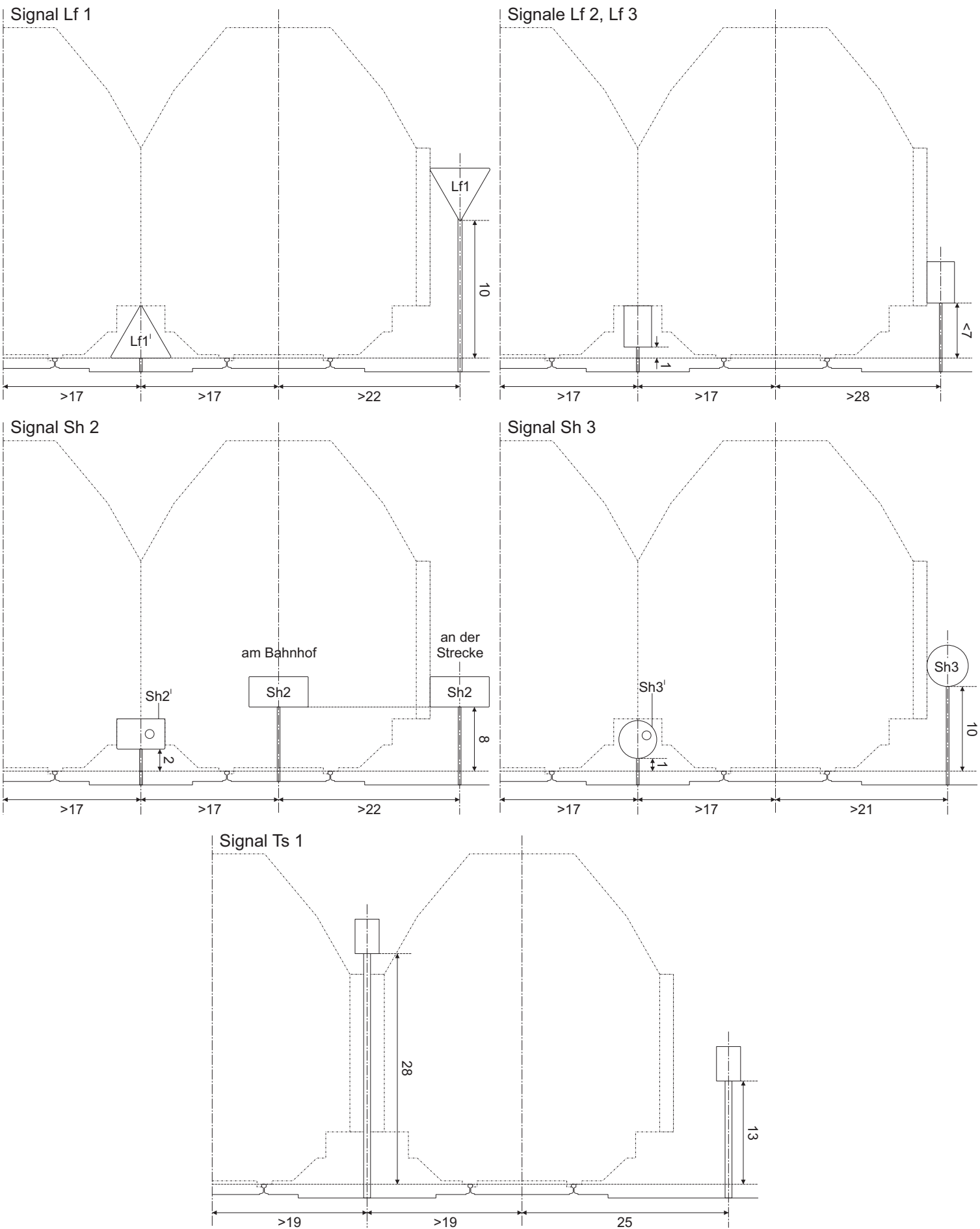

Signale und Kennzeichen der DRG/DR, 1935-1945, 1:120 (TT)

Lage von Kennzeichen gegenüber dem Lademaß 1/4

Kennzeichen K 2, K 4

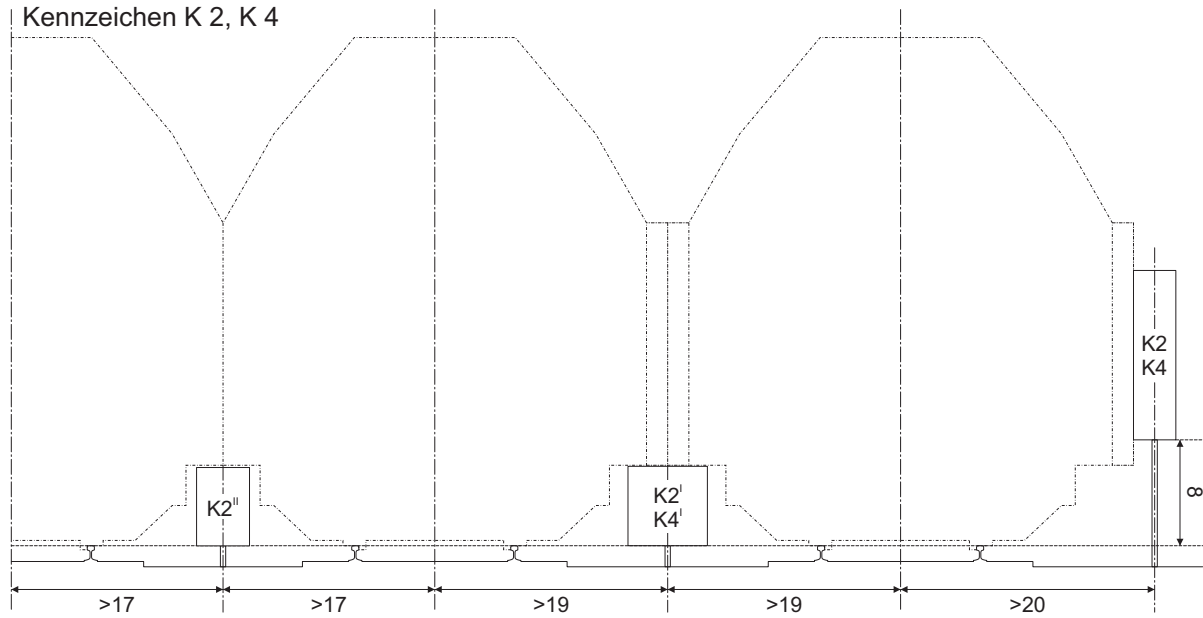

Kennzeichen K 3o, K 3z

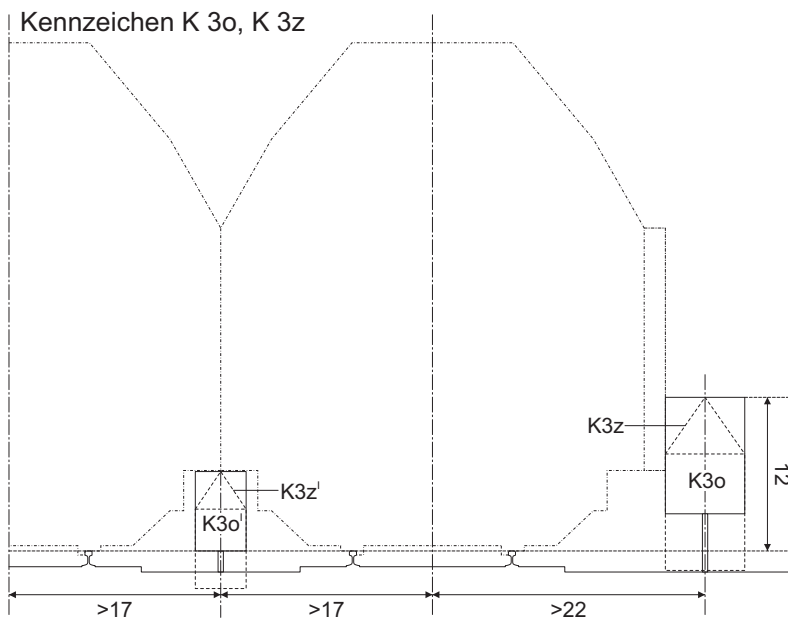

Kennzeichen K 6

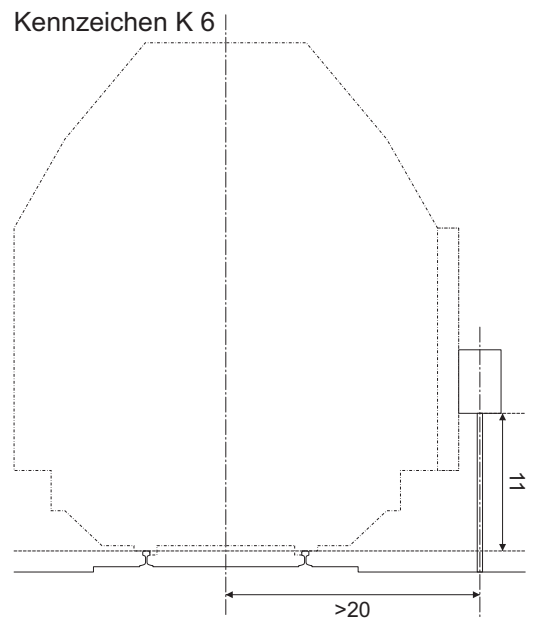

Kennzeichen K 5

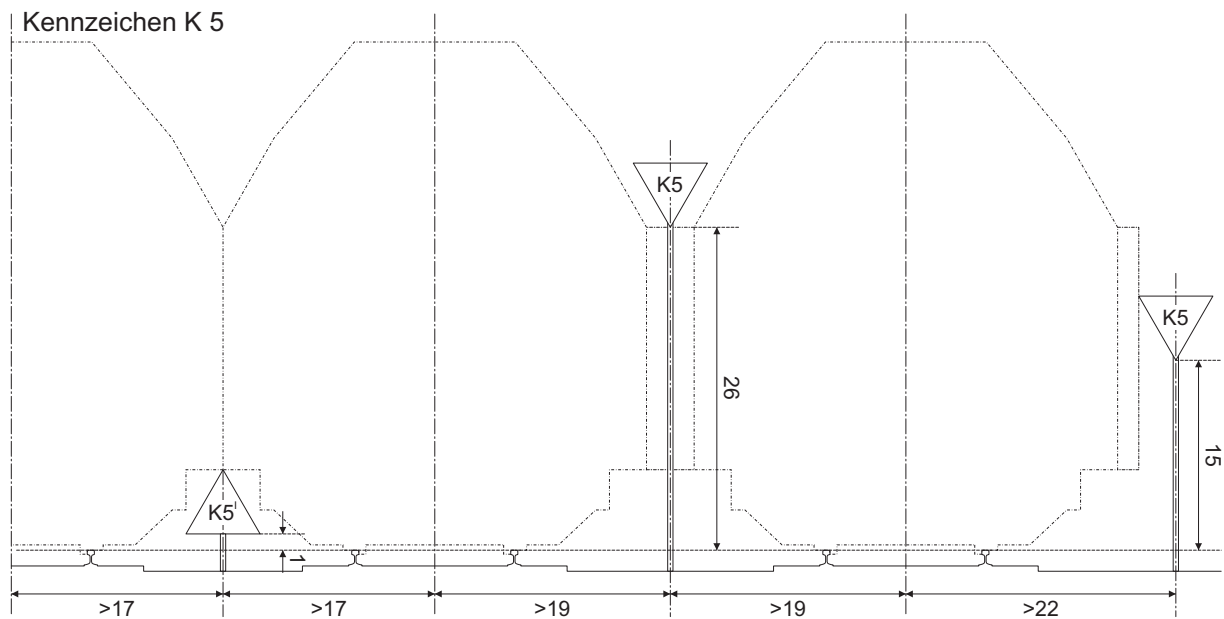

Signale und Kennzeichen der DRG/DR, 1935-1945, 1:120 (TT)

Lage von Kennzeichen gegenüber dem Lademaß 2/4

Bearbeitet bei Pawel Adamowicz (<http://pkprepo.net/>), 2021/2022, ausgewählte Rechte vorbehalten



Kennzeichen K 7a, K 7b

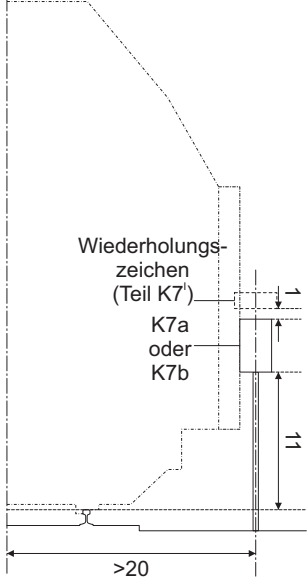

Kennzeichen K 7c

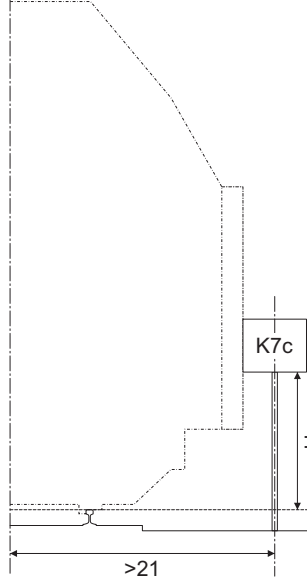

Kennzeichen K 7d

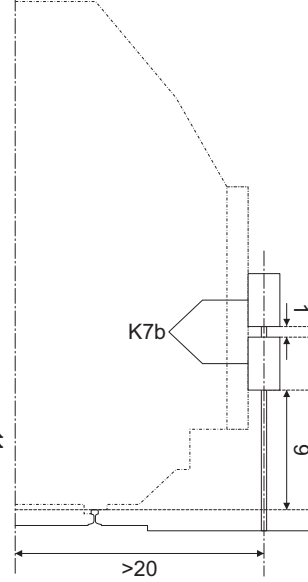

Kennzeichen K 7e

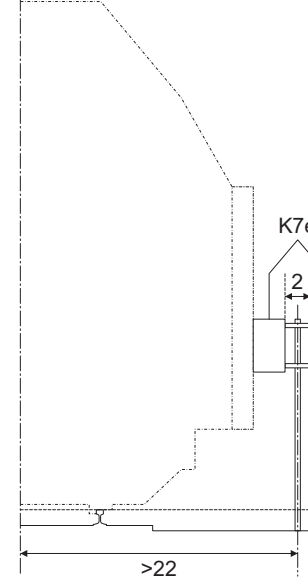

Kennzeichen K 7a, K 7b, K 7c, K 7d mit Geschwindigkeitstafel

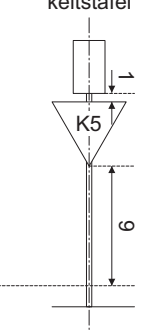

Kennzeichen K 8a

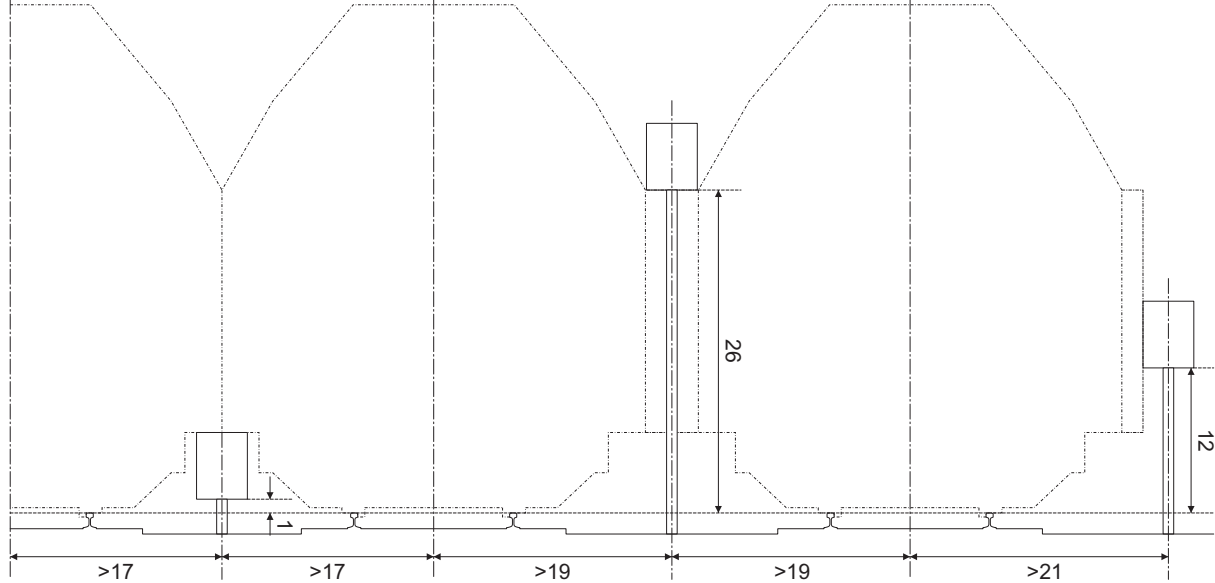

Kennzeichen K 9

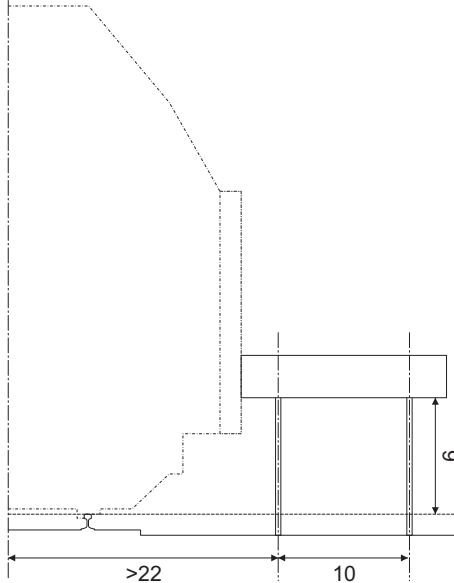

Kennzeichen K 10

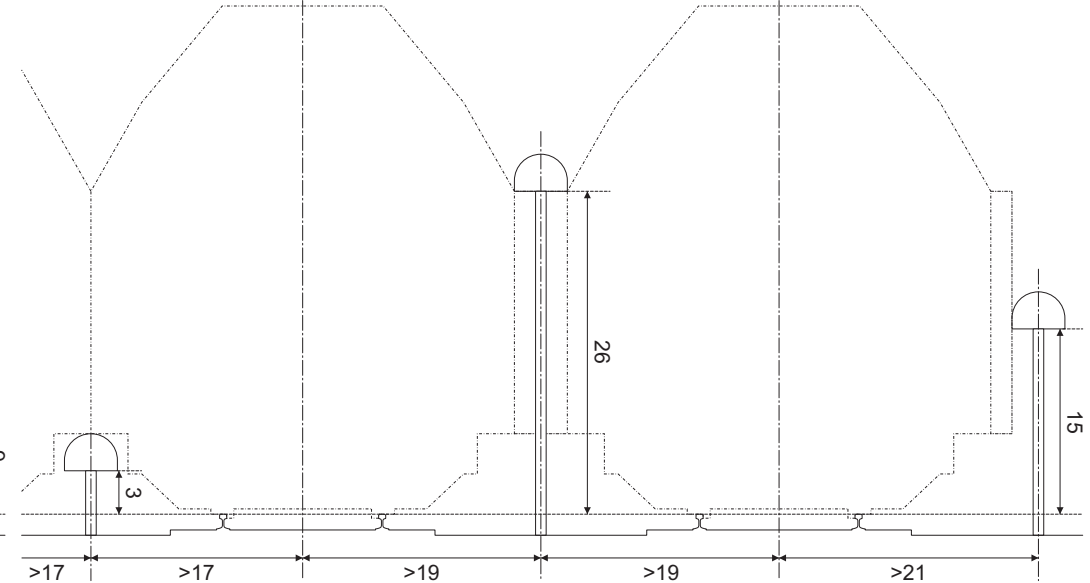

Signale und Kennzeichen der DRG/DR, 1935-1945, 1:120 (TT)

Lage von Kennzeichen gegenüber dem Lademaß 3/4

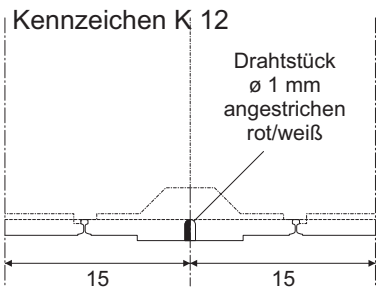

Kennzeichen K 15

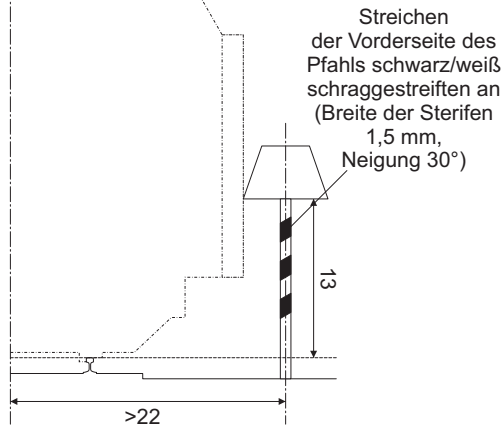

Kennzeichen K 16

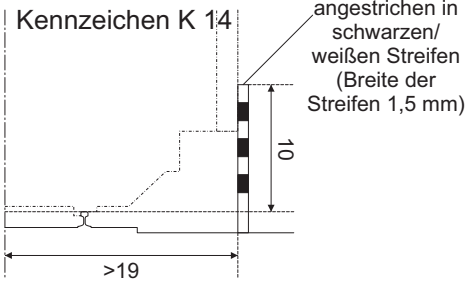
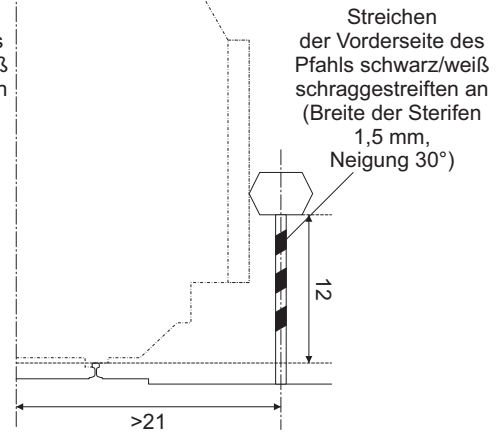

Kennzeichen K 17

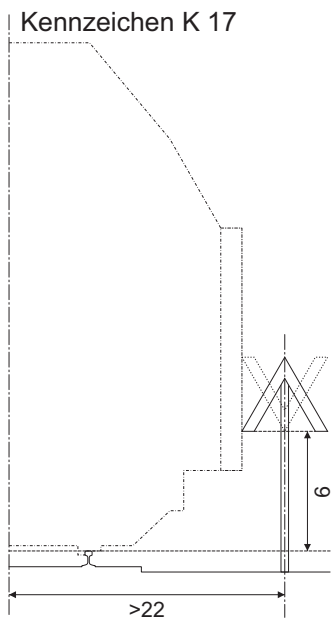

M-Tafel

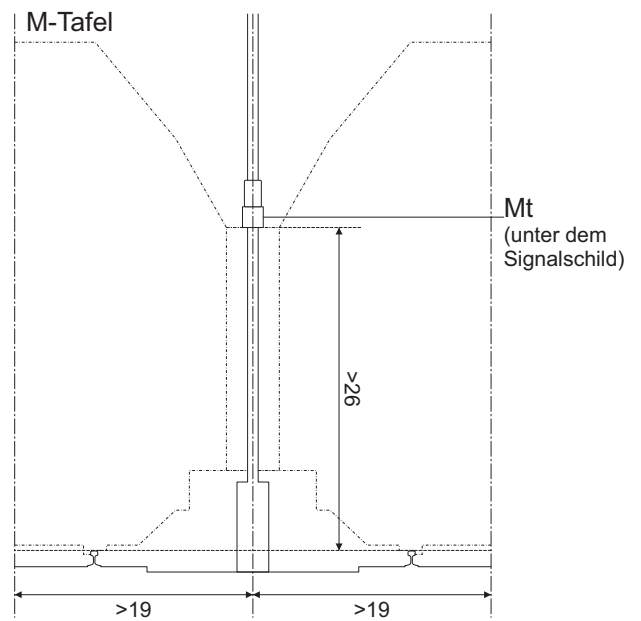

Fahrleitungssignale EI 1-EI 6, K 8b

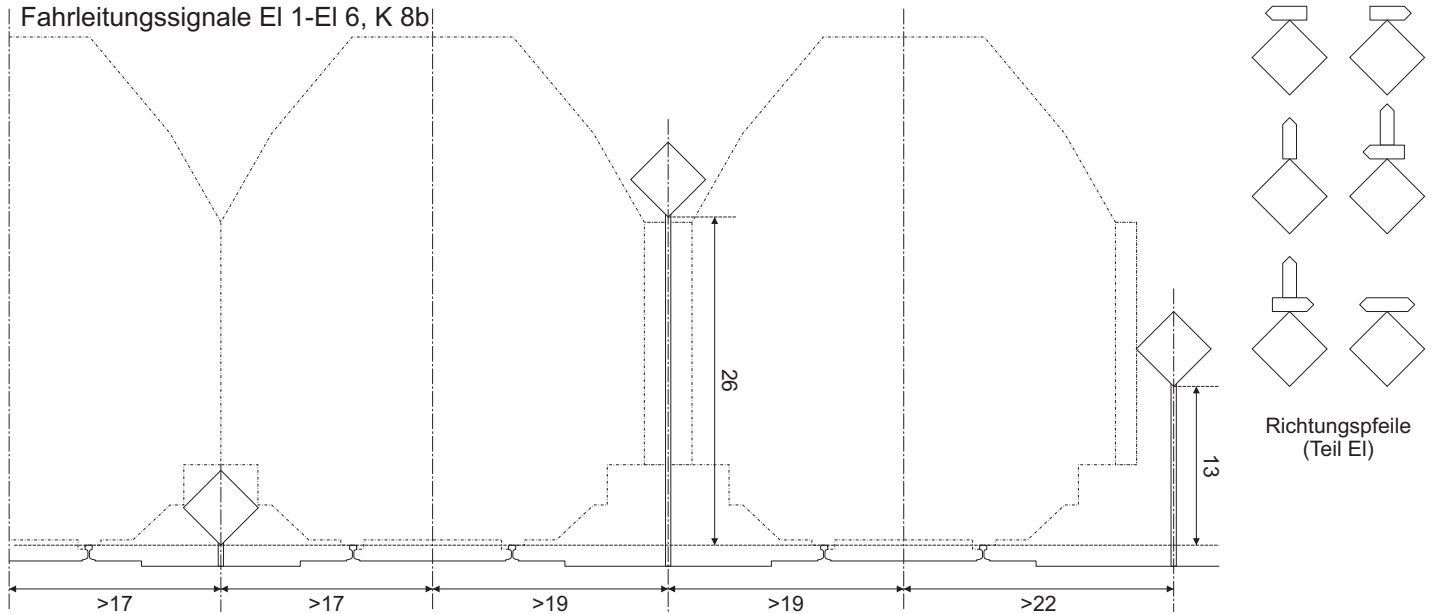

Signale und Kennzeichen der DRG/DR, 1935-1945, 1:120 (TT)

Lage von Kennzeichen gegenüber dem Lademaß 4/4