

Signale und Kennzeichen der DRG/DR, 1935-1945, Maßstab 1:25

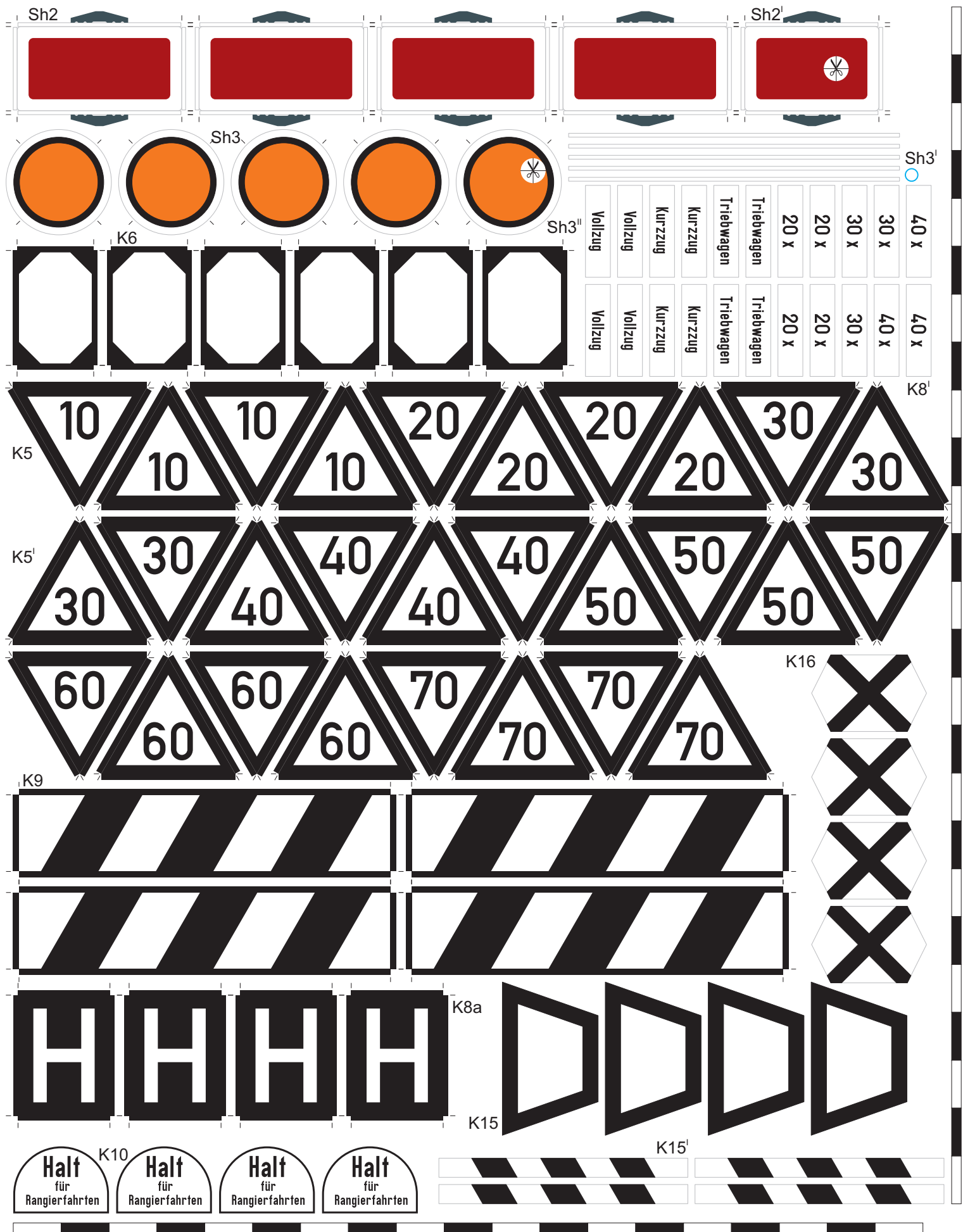

Signale und Kennzeichen der DRG/DR, 1935-1945, Maßstab 1:25

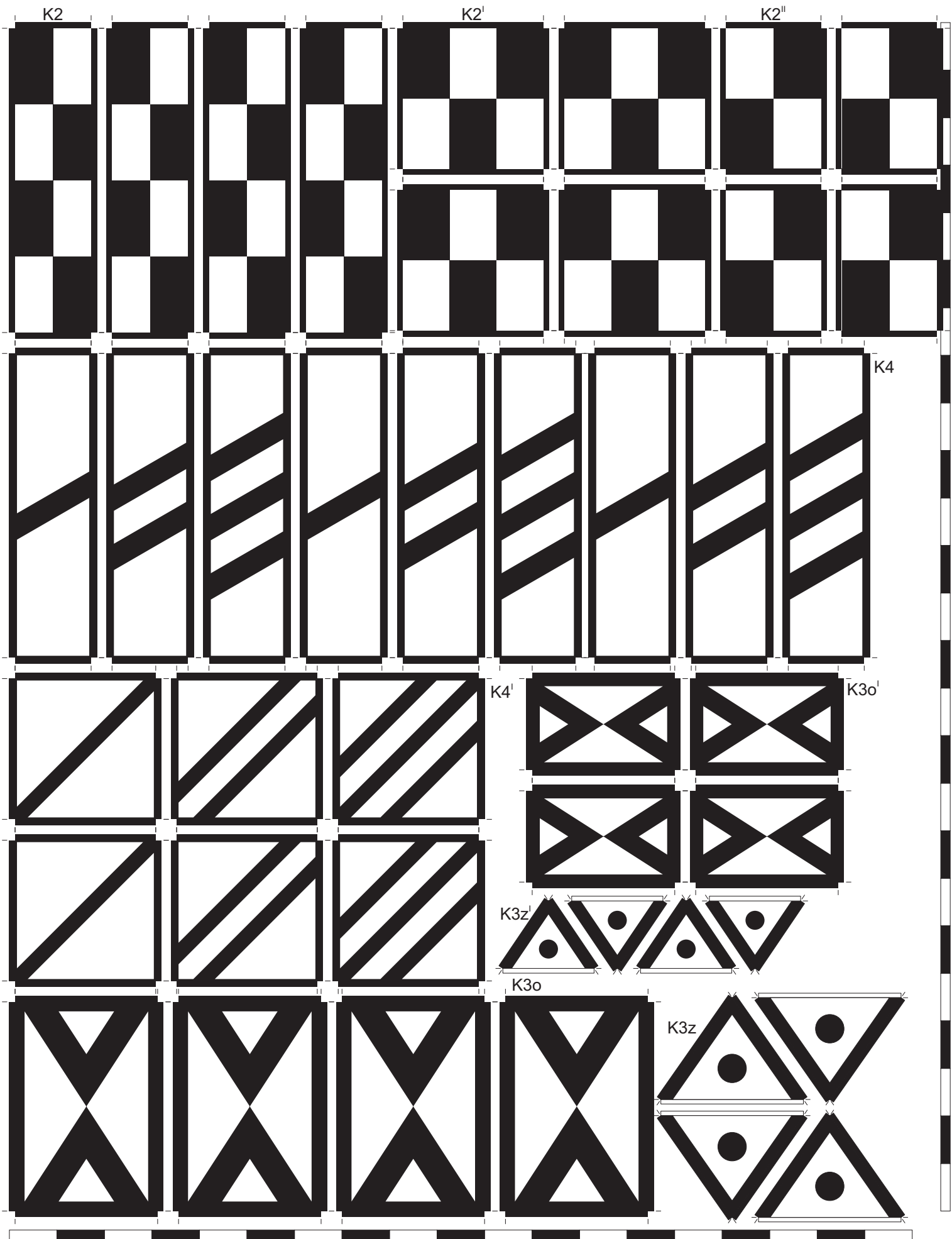

Signale und Kennzeichen der DRG/DR, 1935-1945, Maßstab 1:25

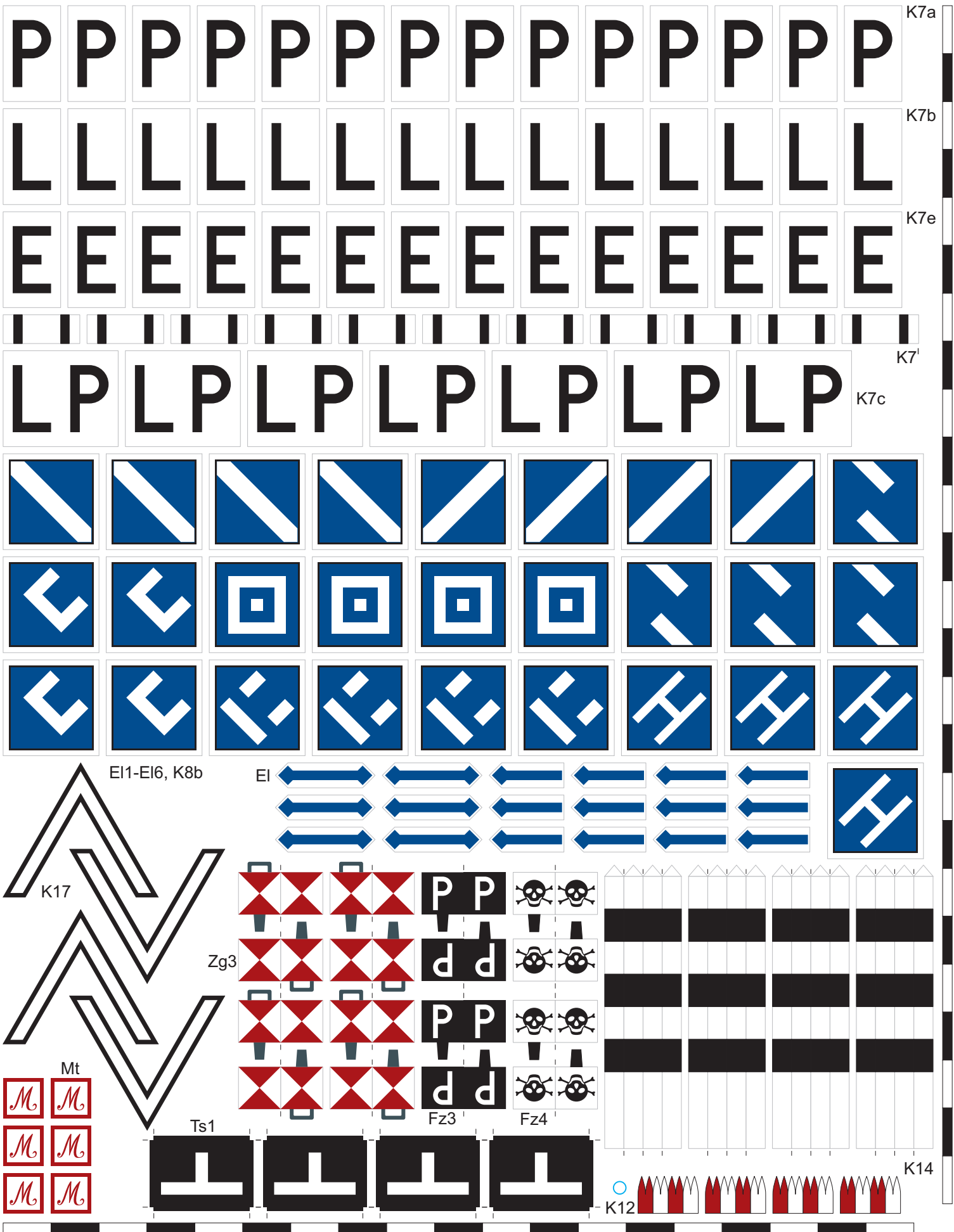

Signale und Kennzeichen der DRG/DR, 1935-1945, Maßstab 1:25

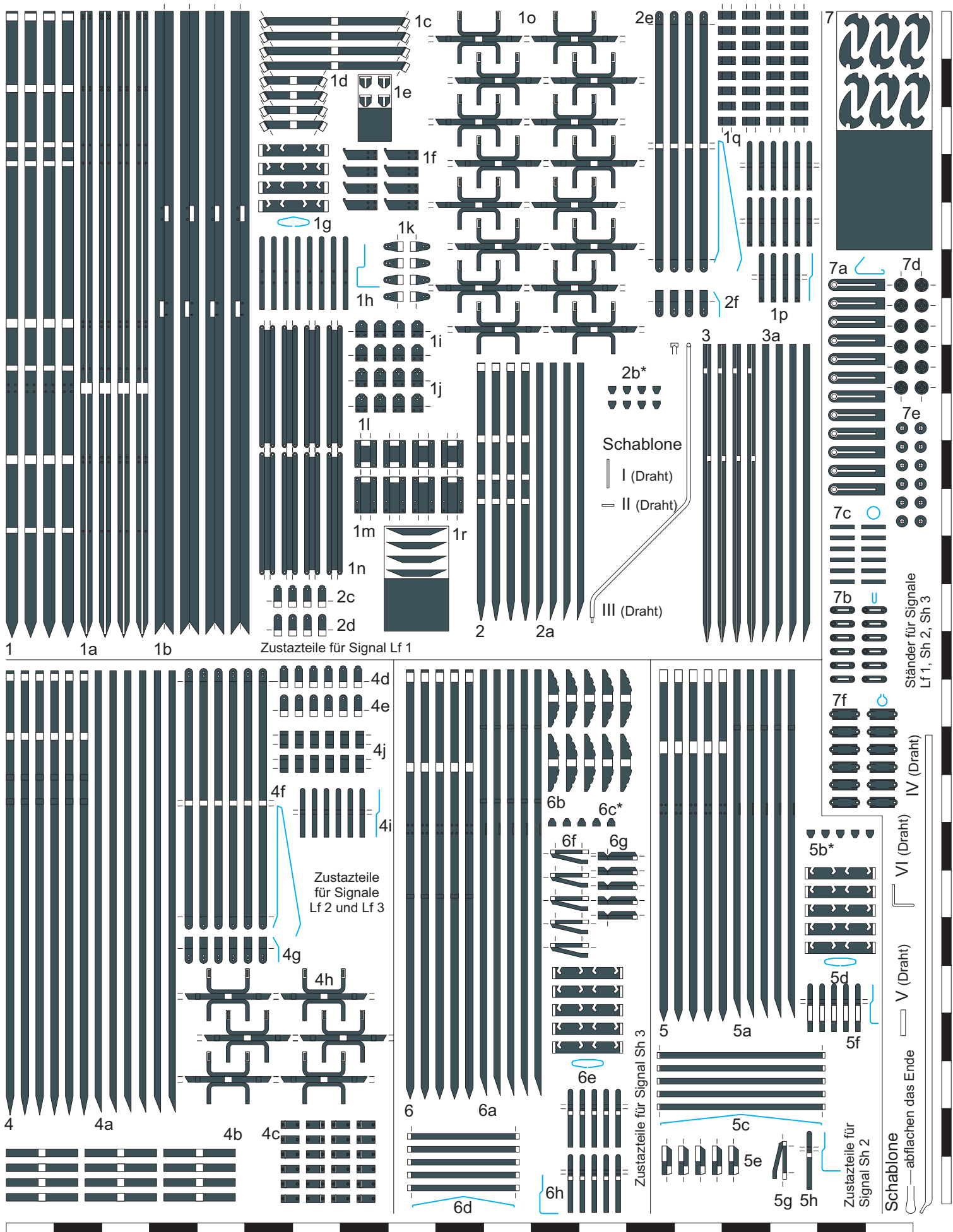

Signale und Kennzeichen der DRG/DR, 1935-1945, Maßstab 1:25

Zustatzteile

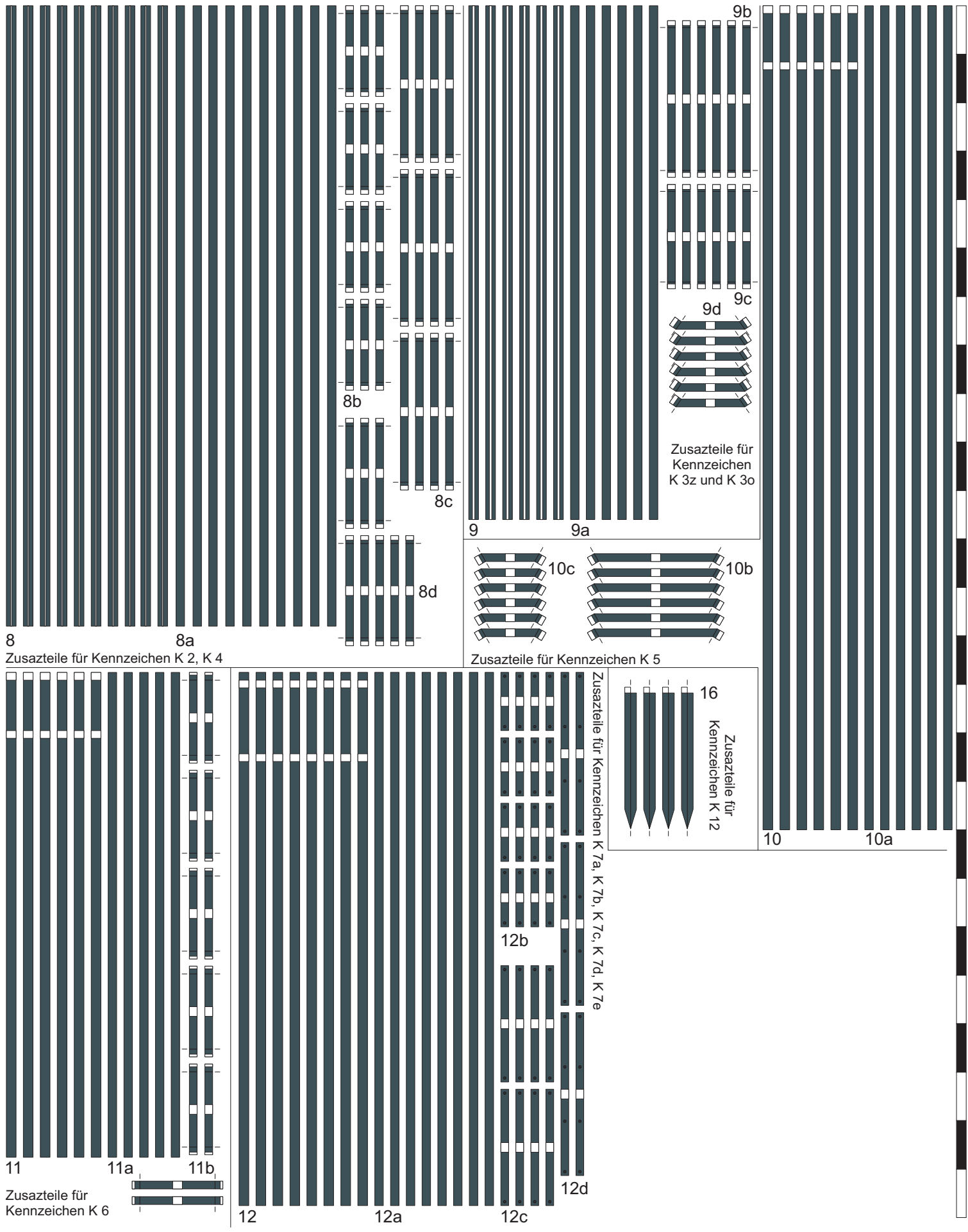

Signale und Kennzeichen der DRG/DR, 1935-1945, Maßstab 1:25

Zusatzteile

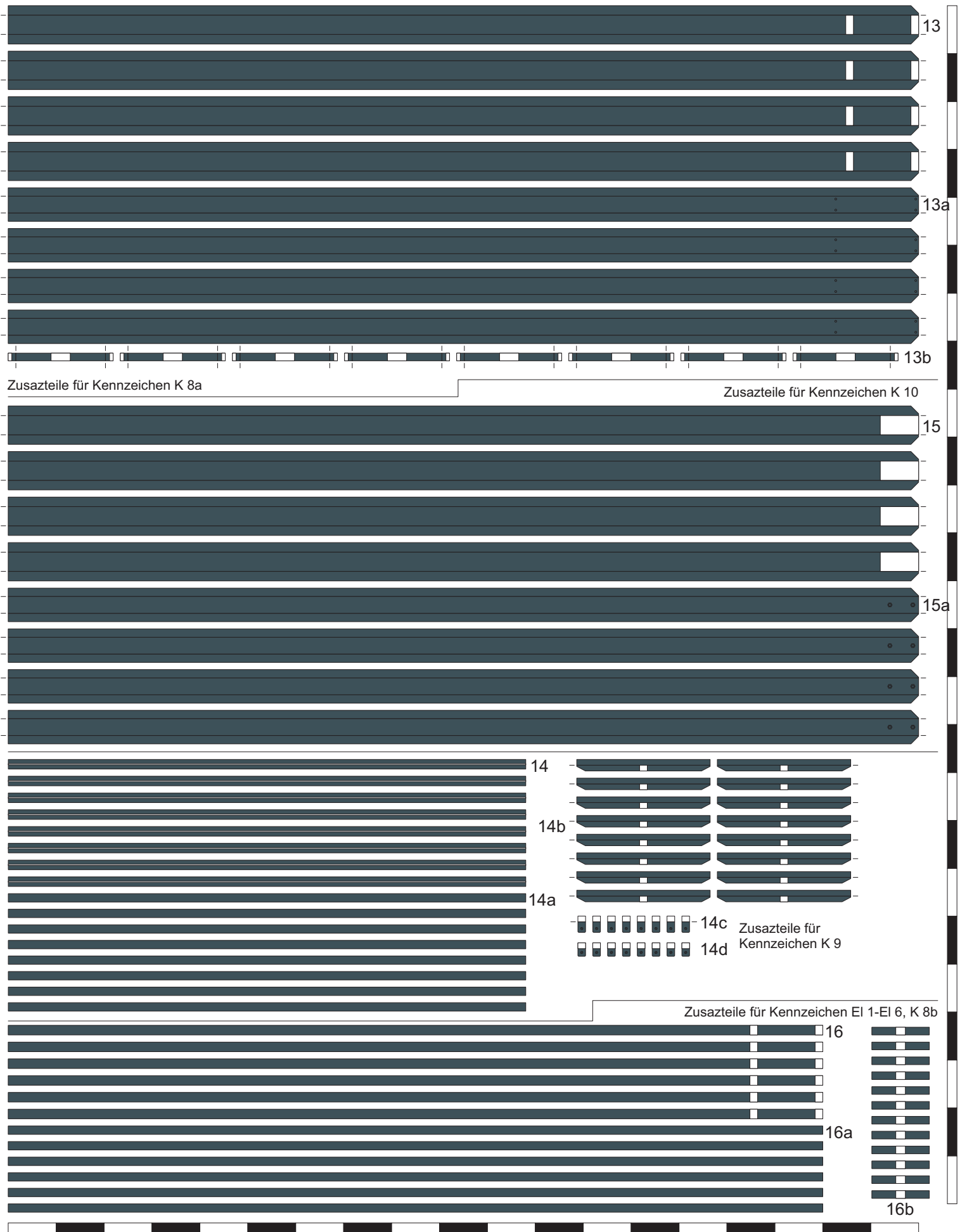

Signale und Kennzeichen der DRG/DR, 1935-1945, Maßstab 1:25

Zusatzteile

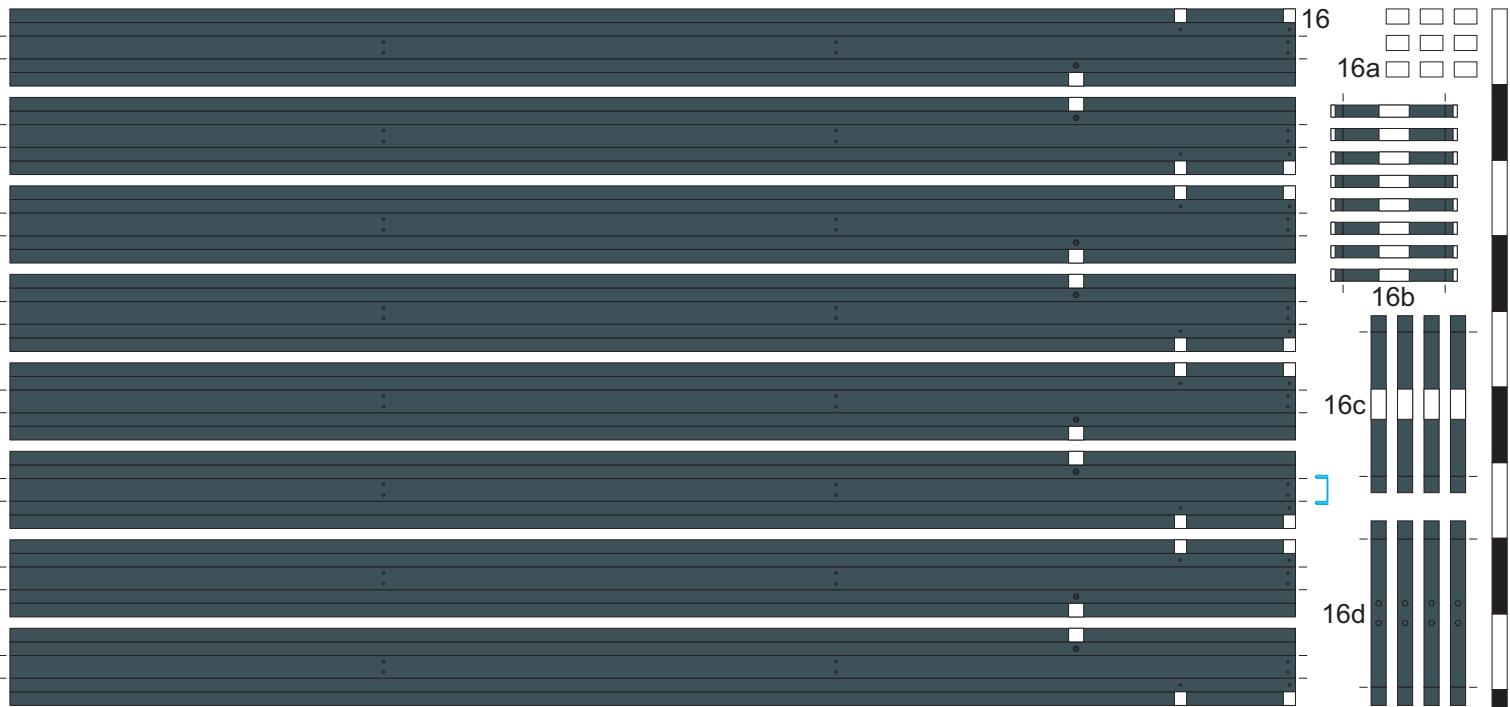

Zusatzteile für Signal Ts 1

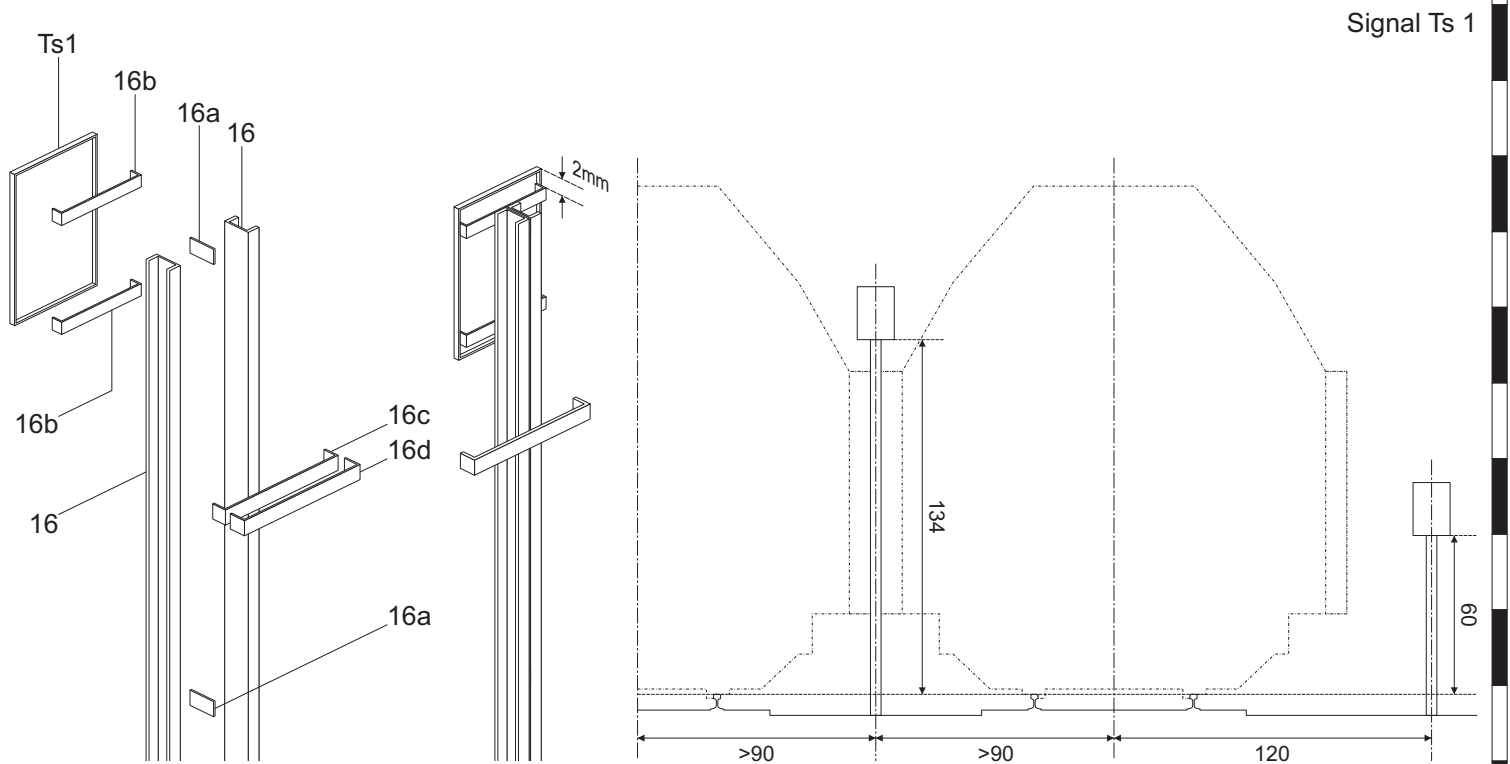

Signale und Kennzeichen der DRG/DR, 1935-1945, Maßstab 1:25

Zusatzteile, Bauanleitung 1/10

Signal Lf 1

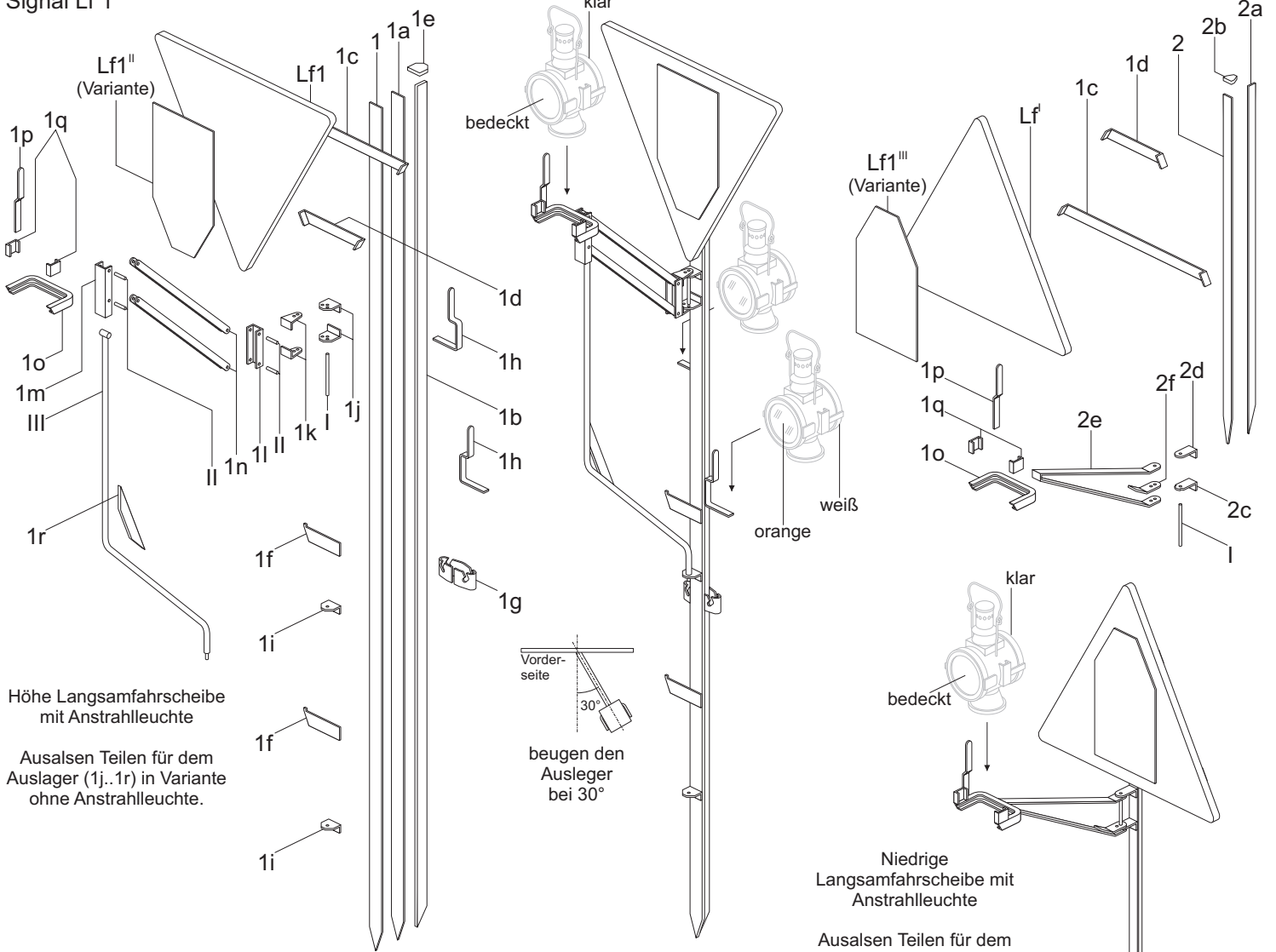

Ständer für Signallichter (aufstellen ~150mm vor niedriger Signal).

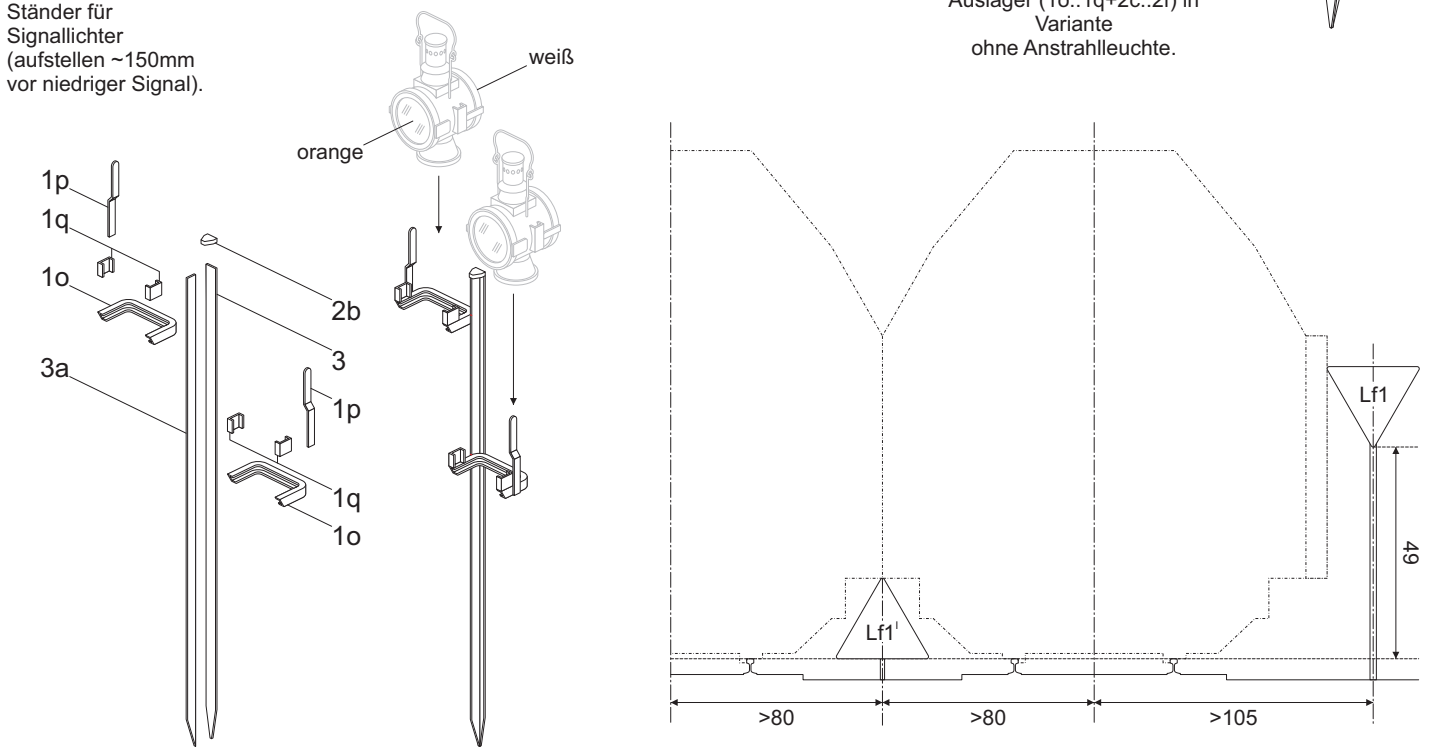

Signale und Kennzeichen der DRG/DR, 1935-1945, Maßstab 1:25

Bauanleitung 2/10

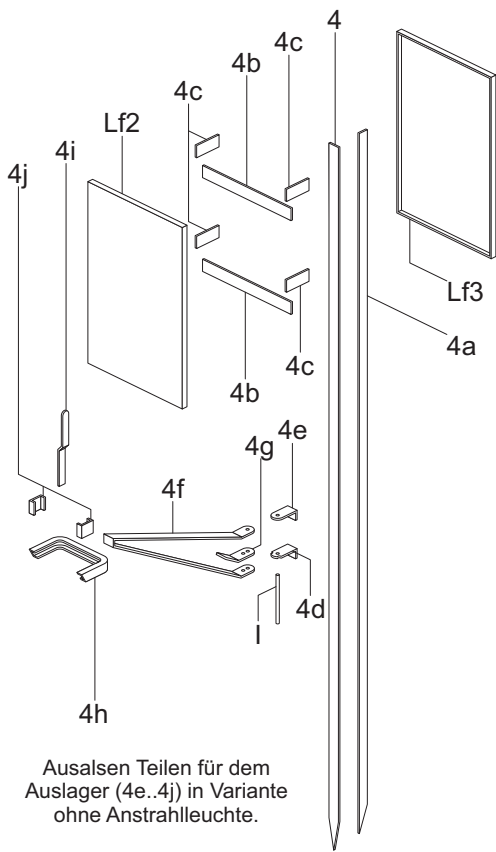

Auslesen Teilen für dem Auslager (4e..4j) in Variante ohne Anstrahlleuchte.

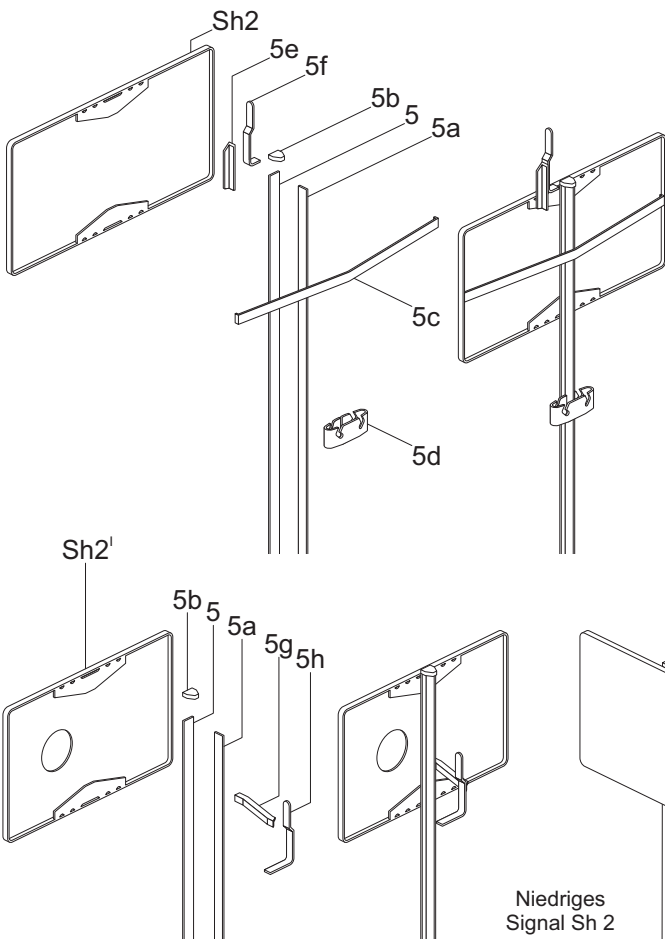
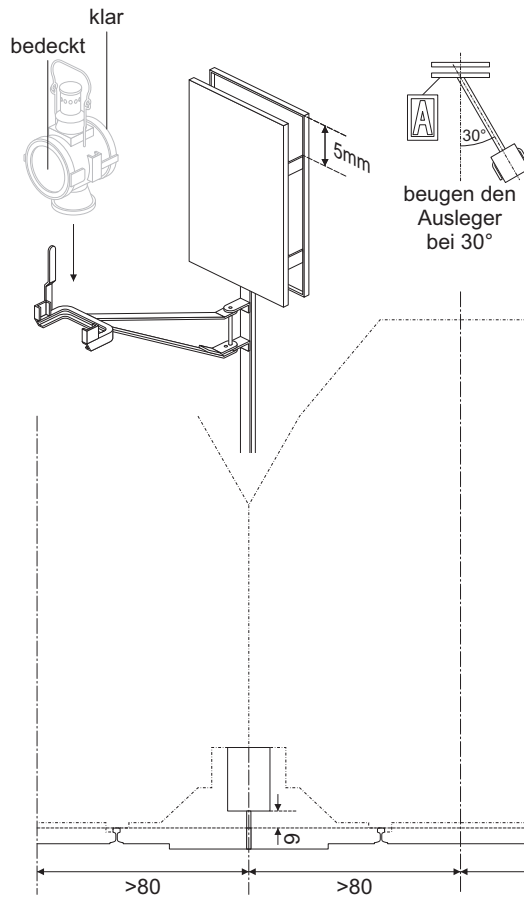

Niedriges Signal Sh 2

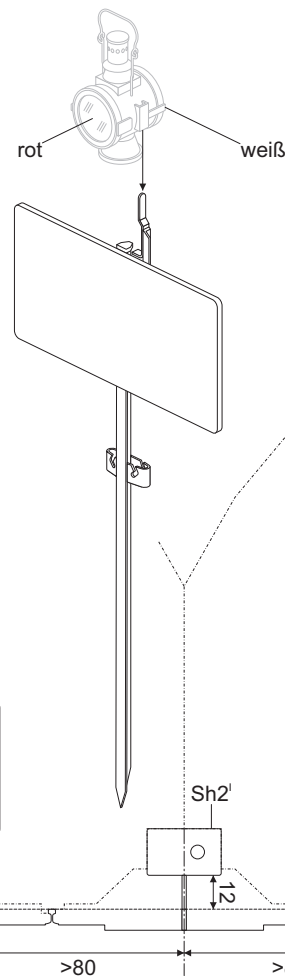

am Bahnhof

an der Strecke

Signale und Kennzeichen der DRG/DR, 1935-1945, Maßstab 1:25

Bauanleitung 3/10

Bearbeitet bei Pawel Adamowicz (<http://pkprepo.net/>), 2021/2022, ausgewählte Rechte vorbehalten



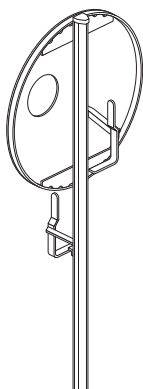
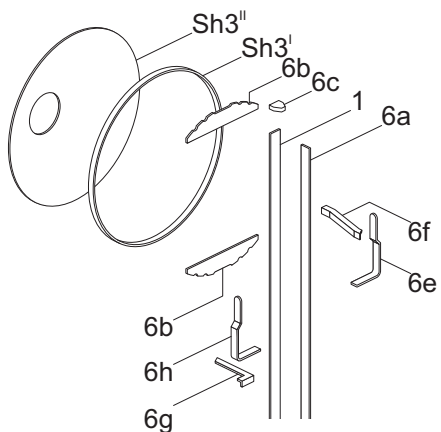
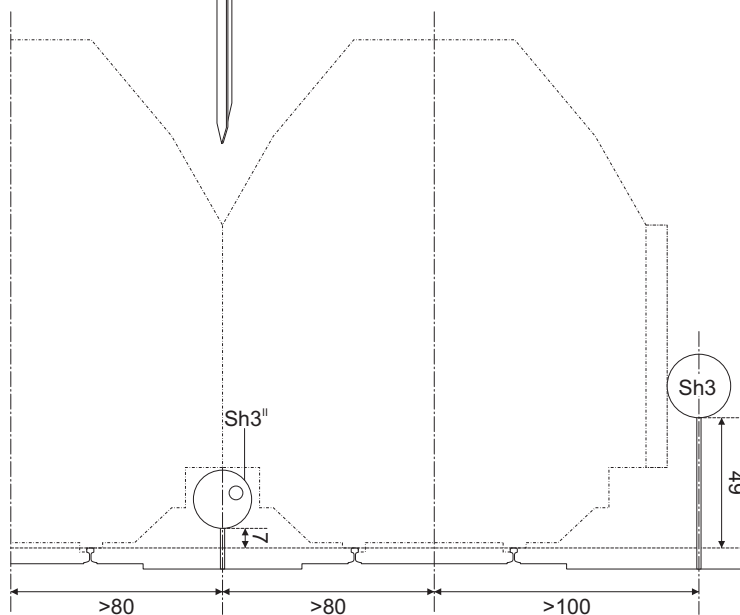
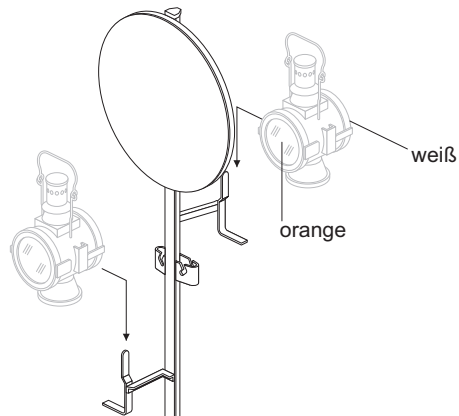
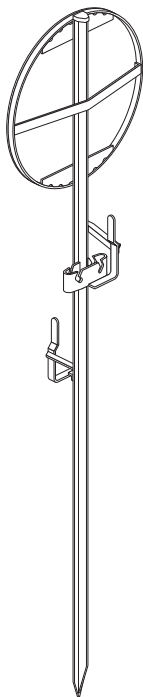
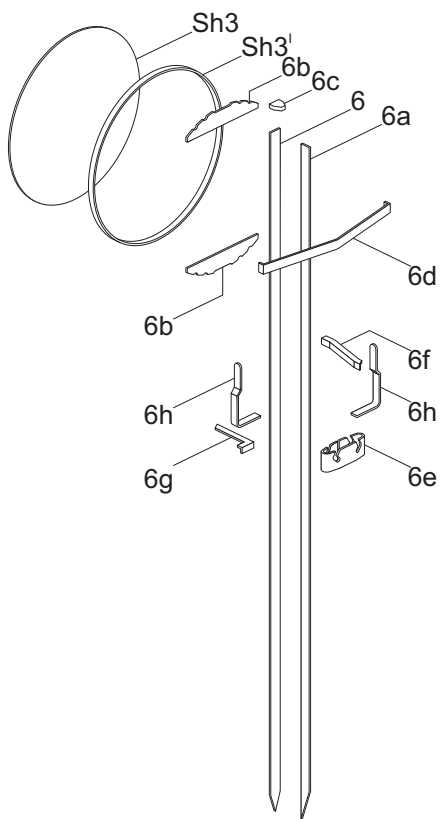

Niedriges Signal Sh 3

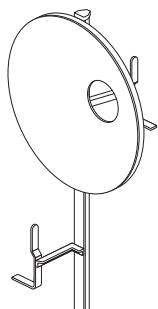

Ständer für Signale Lf 1, Sh 2, Sh 3 (Variante)

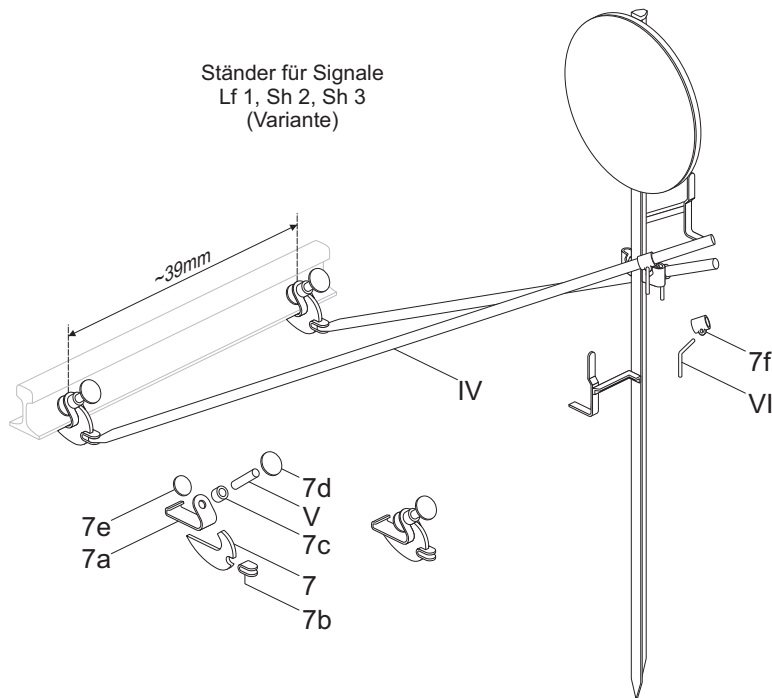

Signale und Kennzeichen der DRG/DR, 1935-1945, Maßstab 1:25

Bauanleitung 4/10

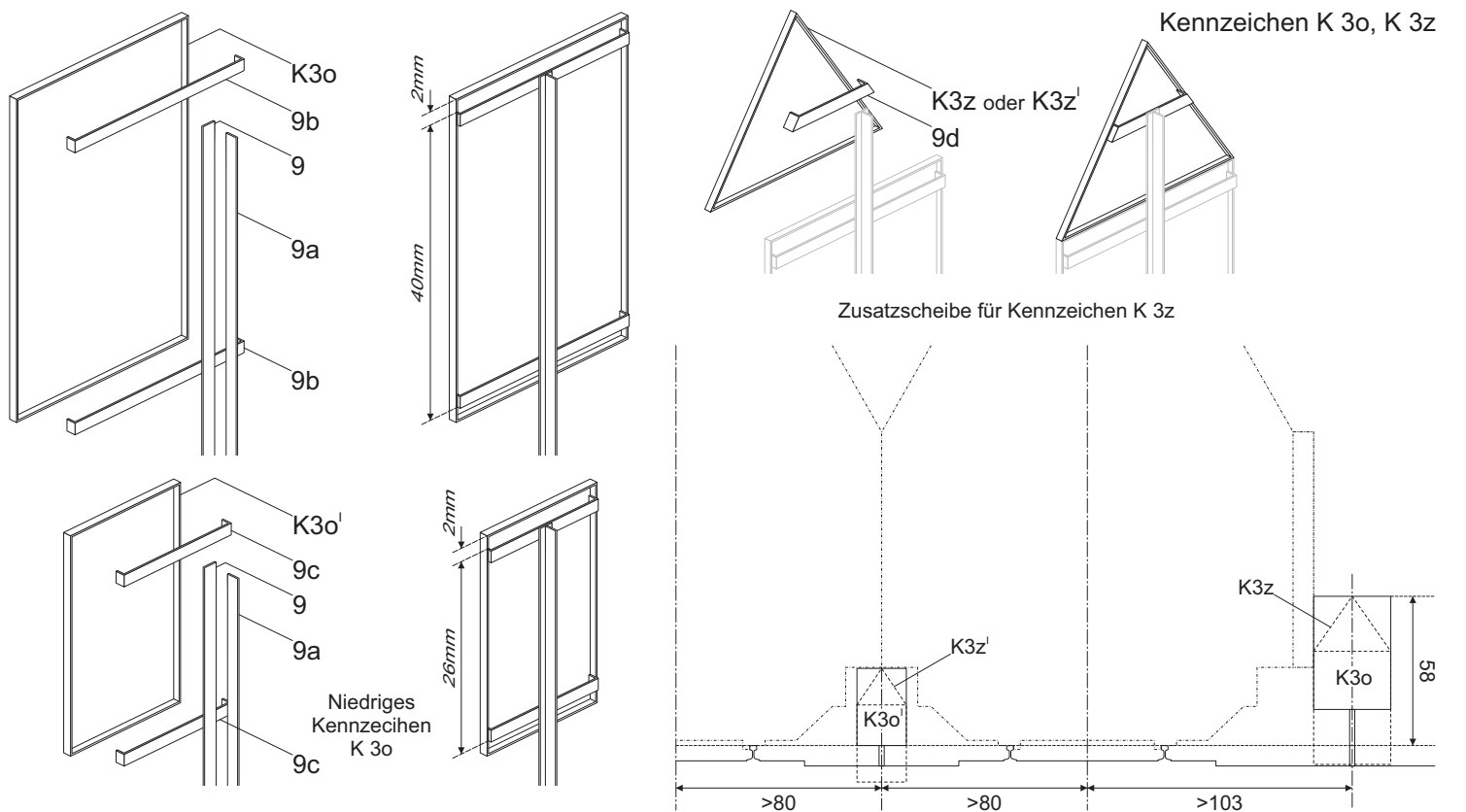
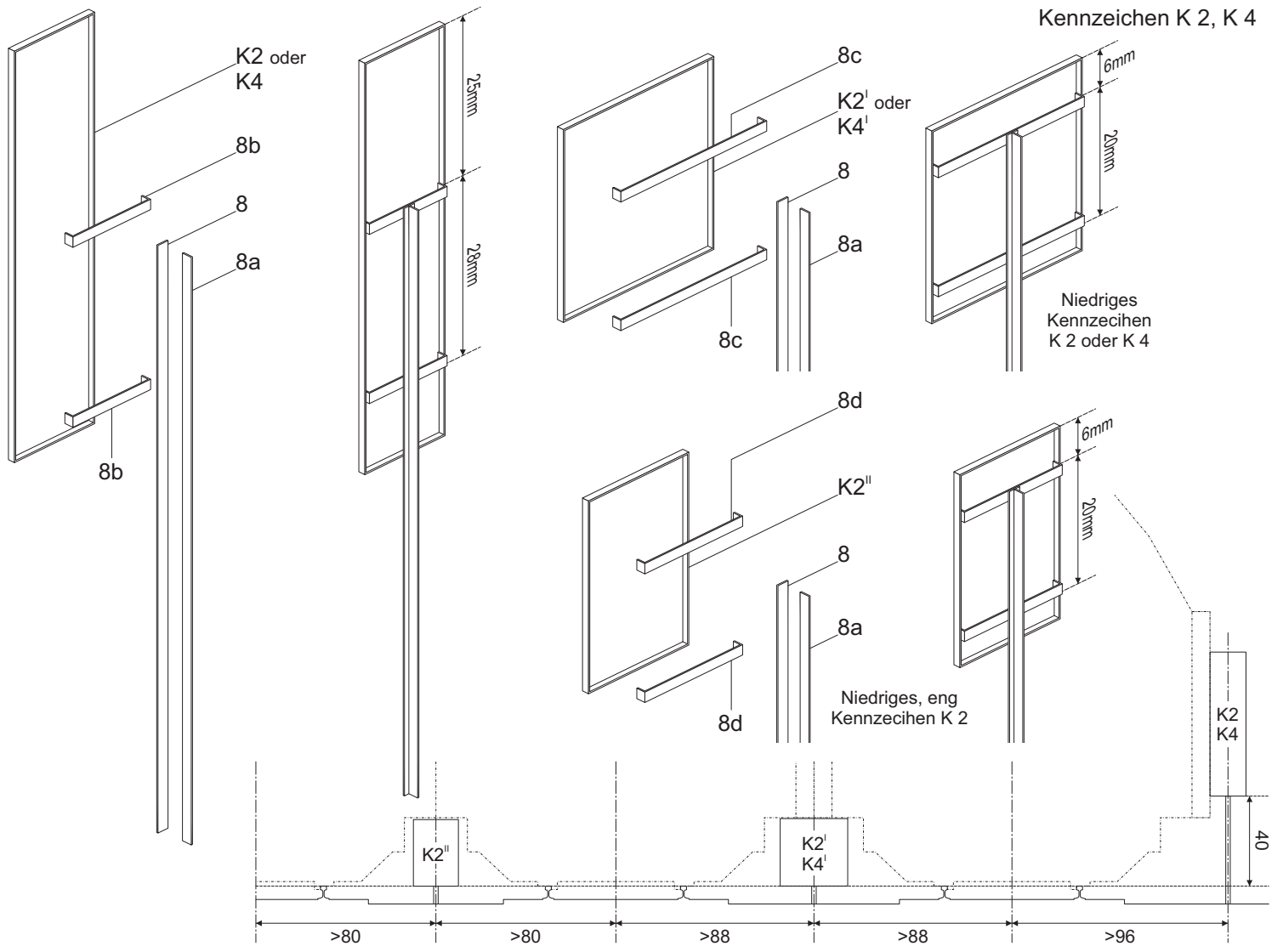

Signale und Kennzeichen der DRG/DR, 1935-1945, Maßstab 1:25

Bauanleitung 5/10

Bearbeitet bei Pawel Adamowicz (<http://pkprepo.net/>), 2021/2022, ausgewählte Rechte vorbehalten



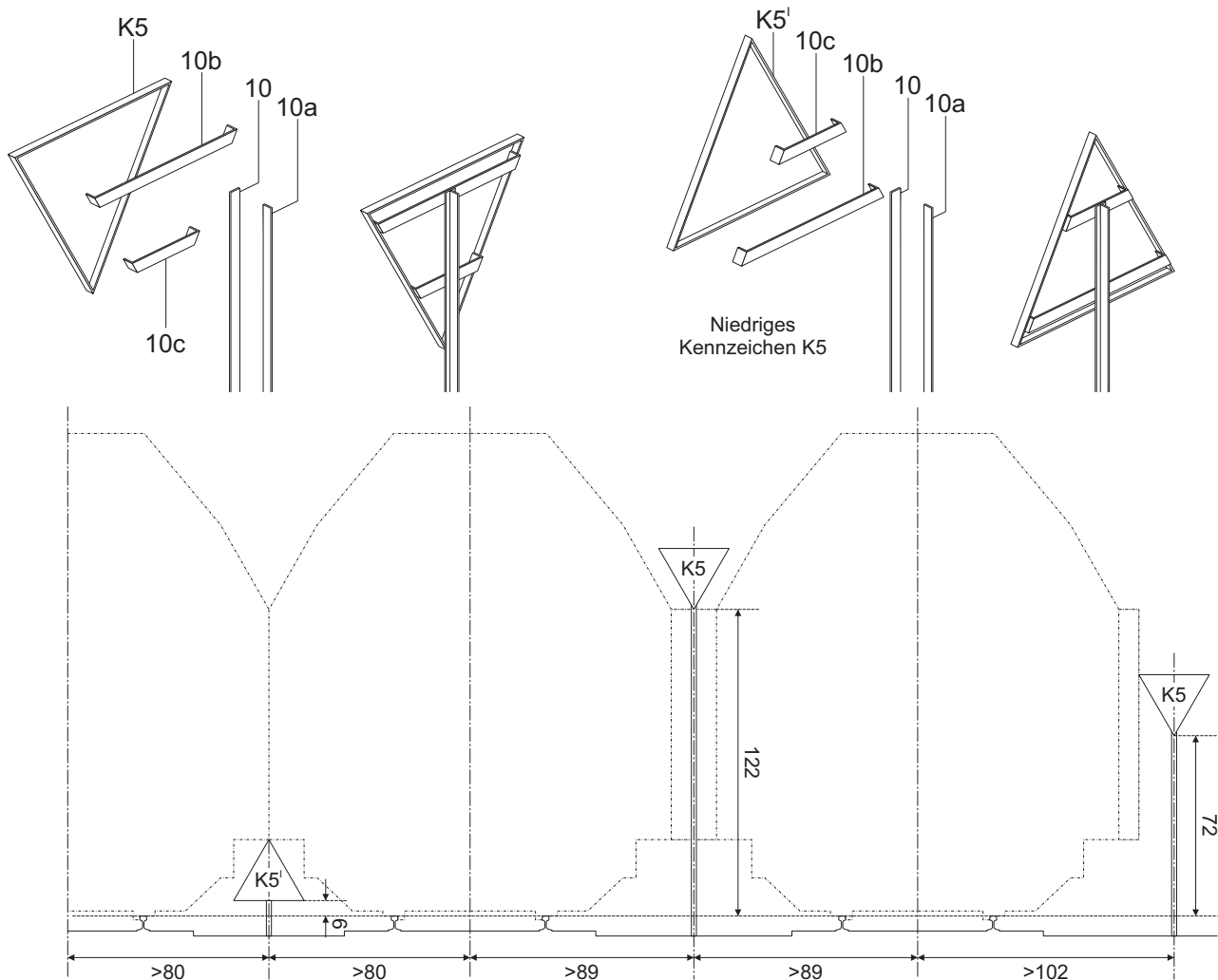

Kennzeichen K 6

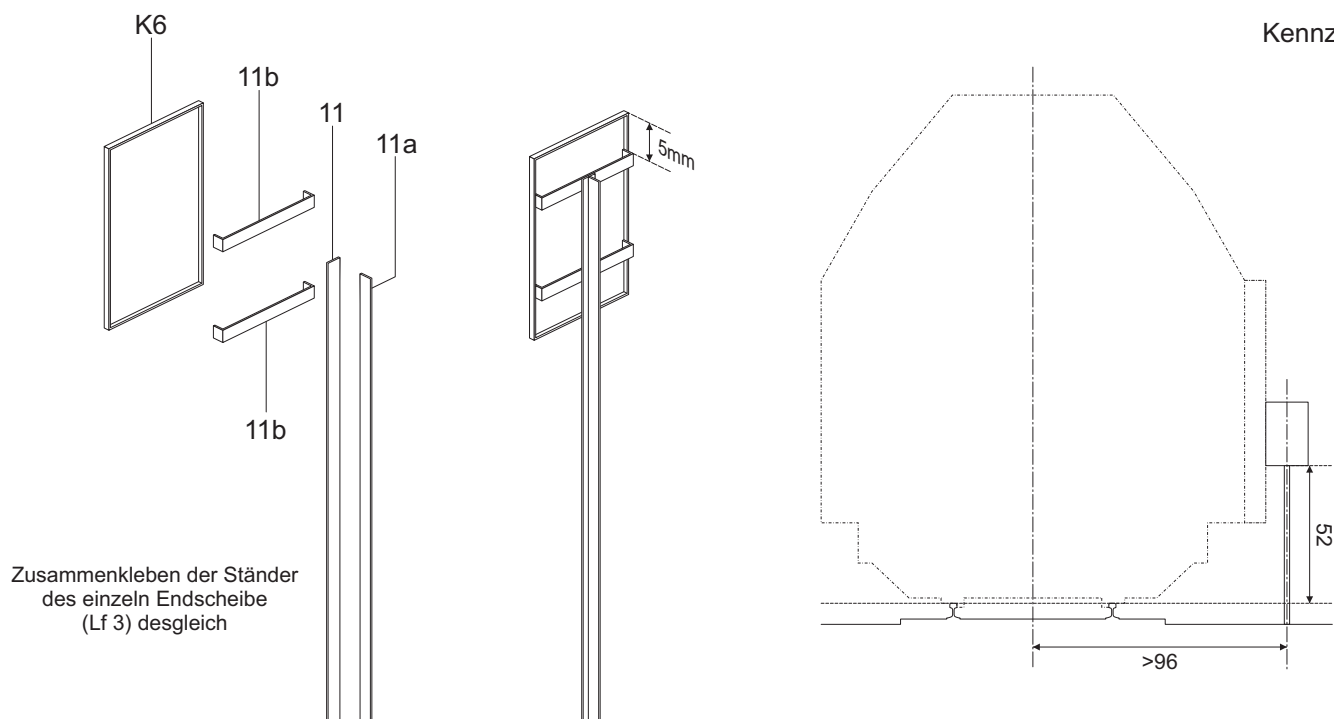

Signale und Kennzeichen der DRG/DR, 1935-1945, Maßstab 1:25

Bauanleitung 6/10

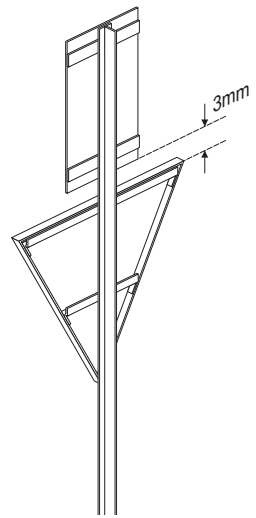
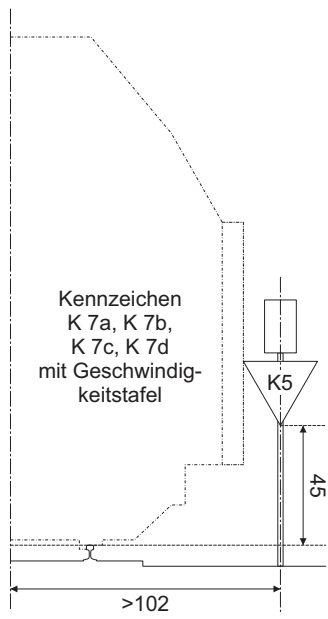
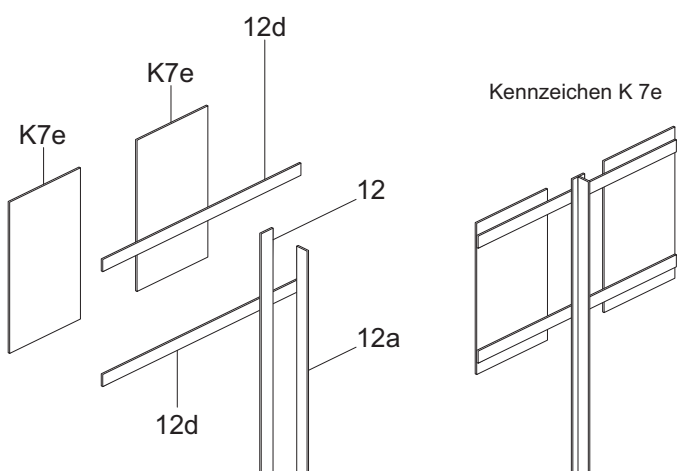
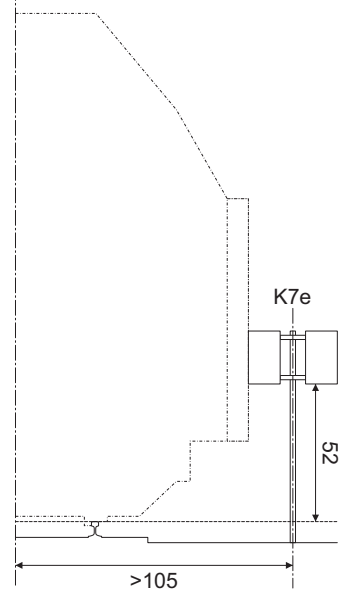
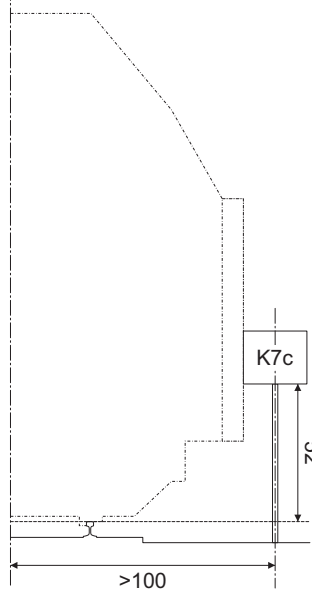
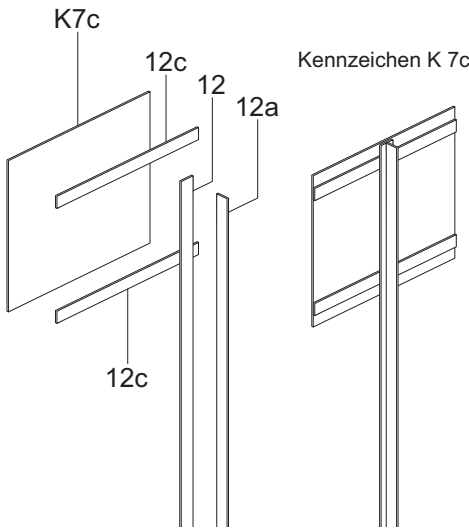
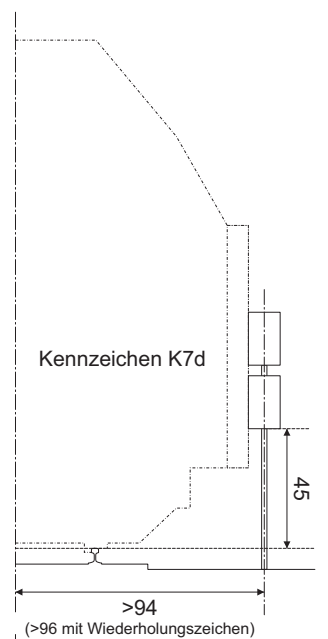
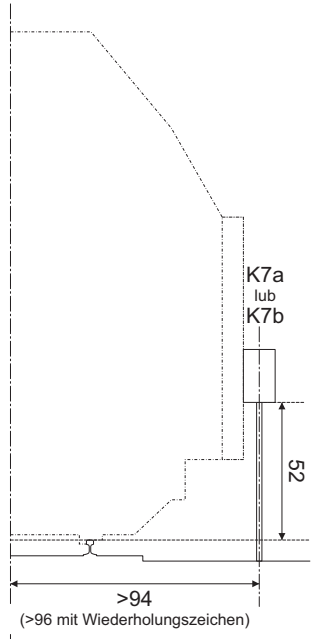
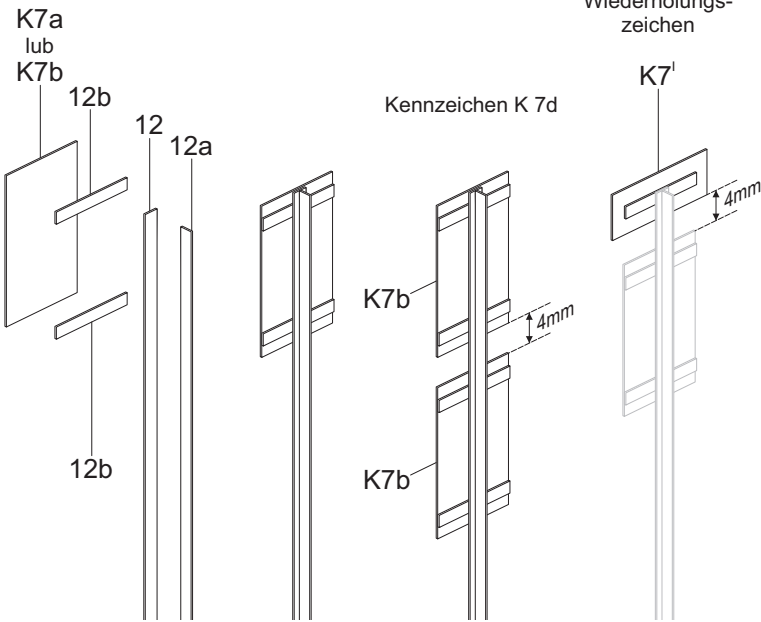

Signale und Kennzeichen der DRG/DR, 1935-1945, Maßstab 1:25

Bauanleitung 7/10

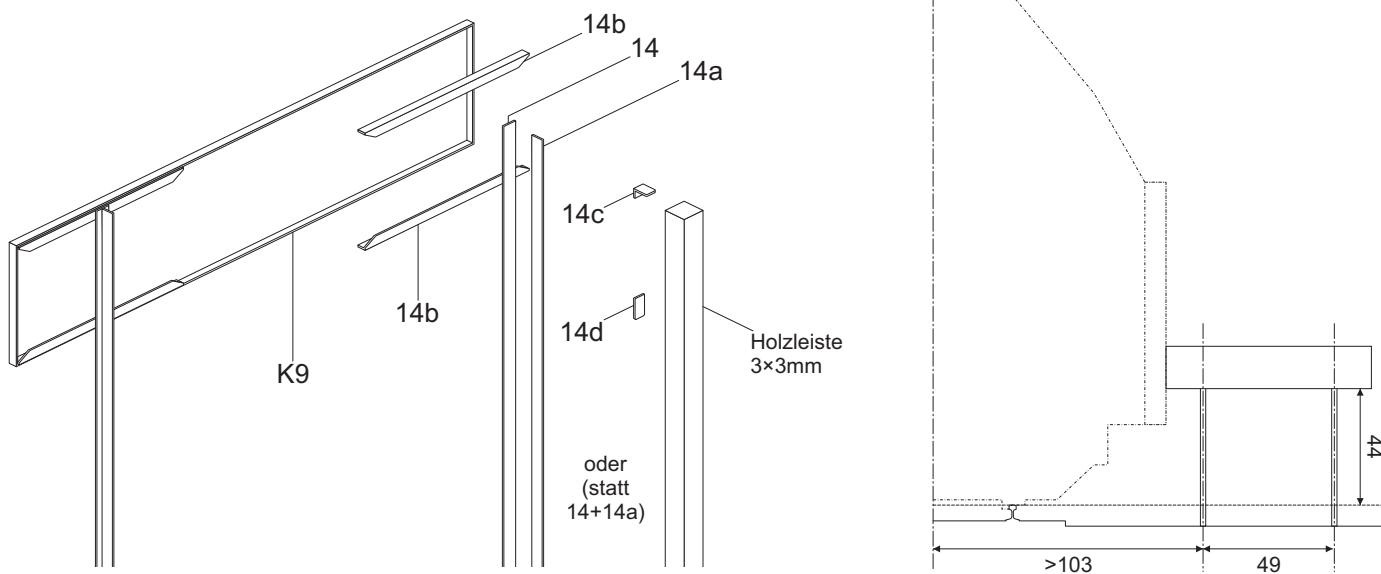
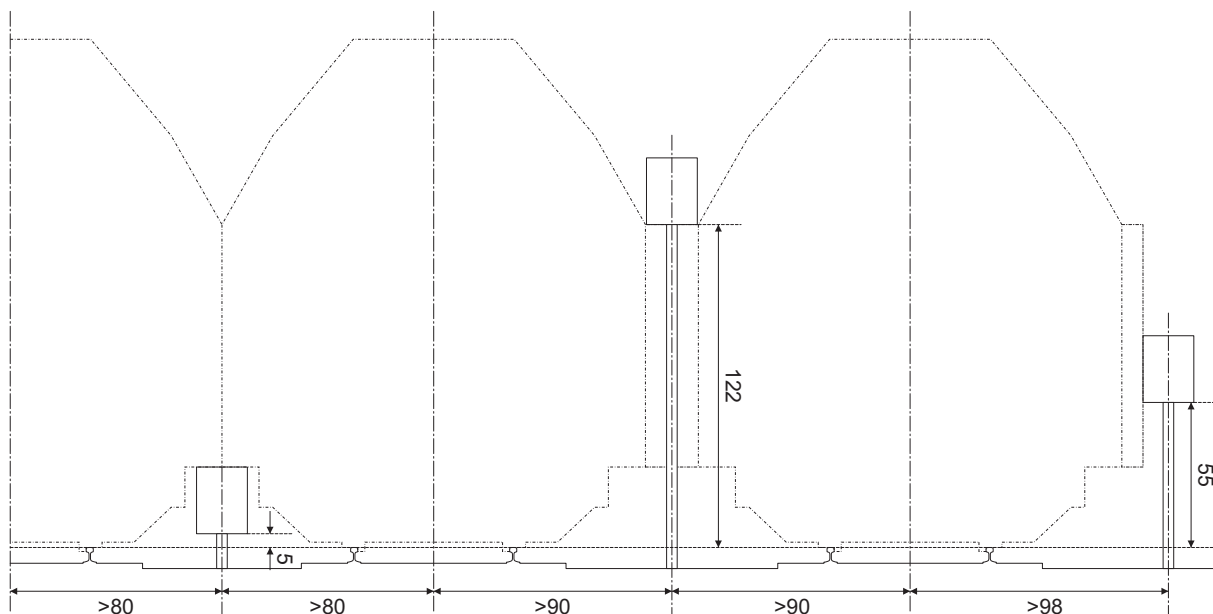
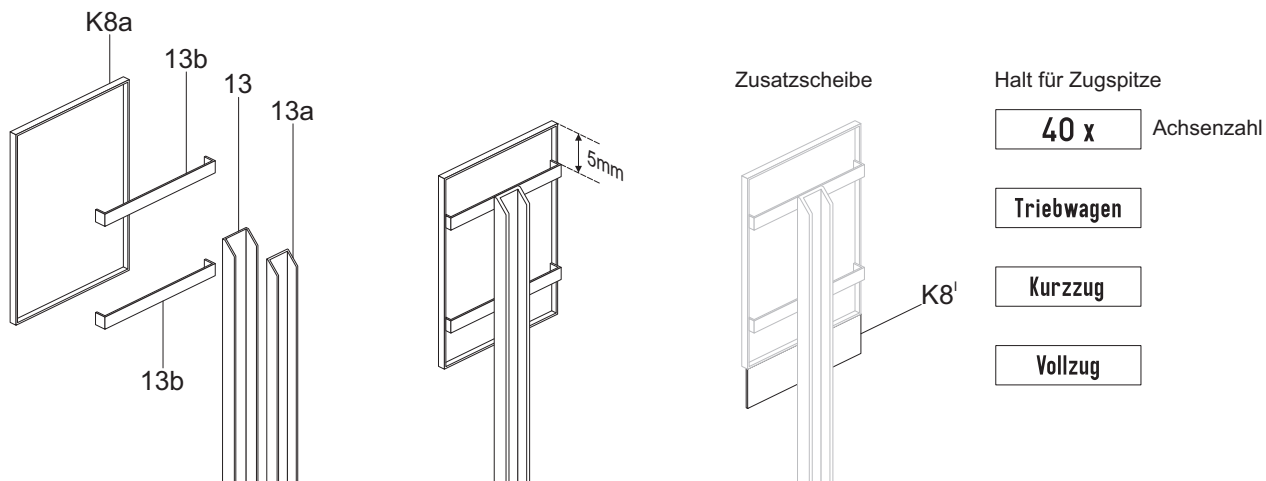

Signale und Kennzeichen der DRG/DR, 1935-1945, Maßstab 1:25

Bauanleitung 8/10

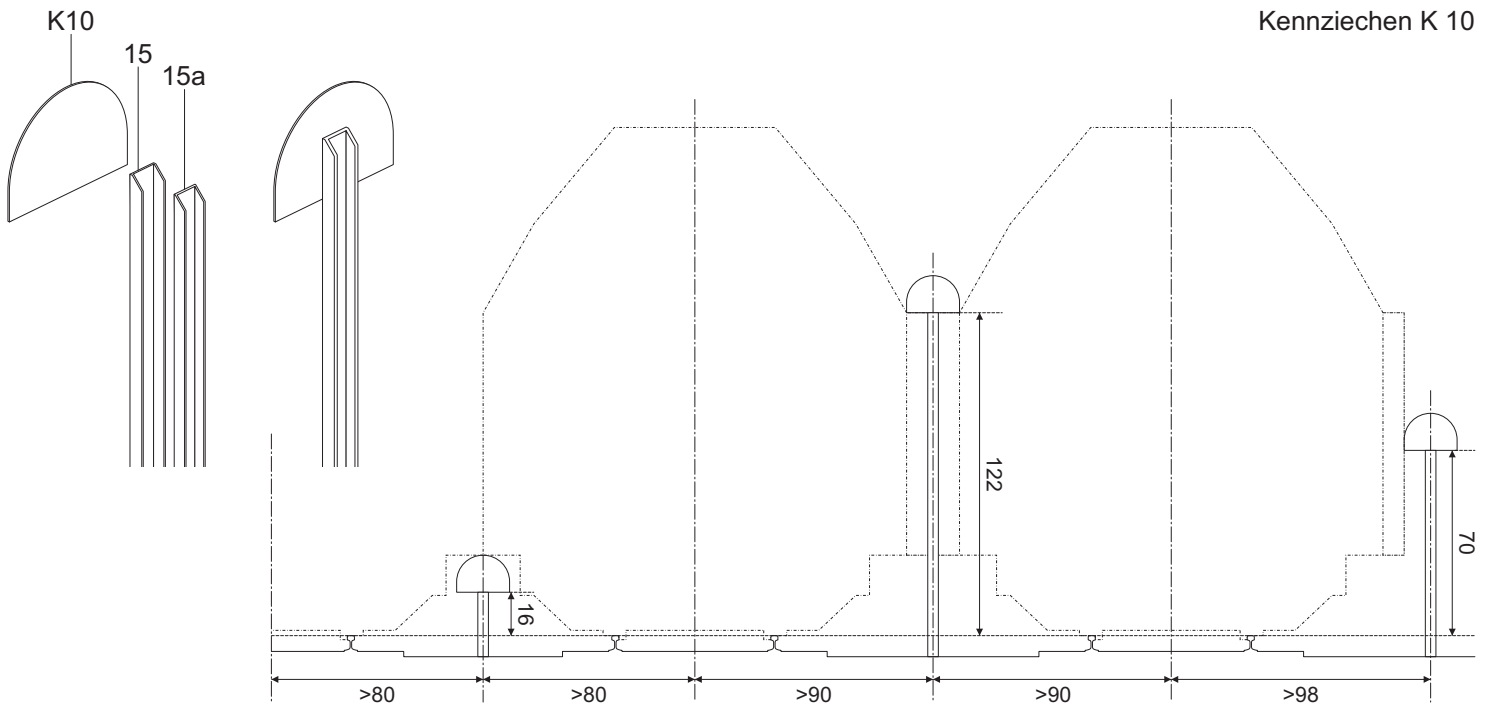

Kennzeichen K 12

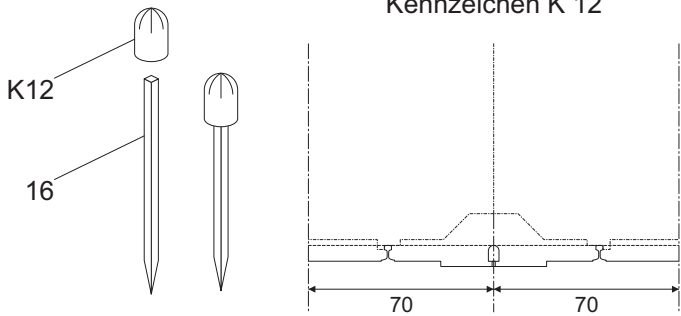

Kennzeichen K 14

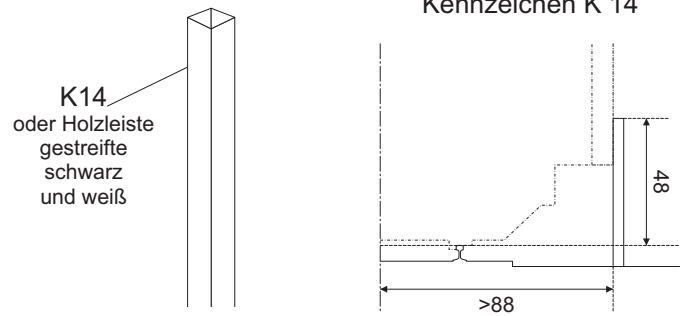

Wskaźnik K 15

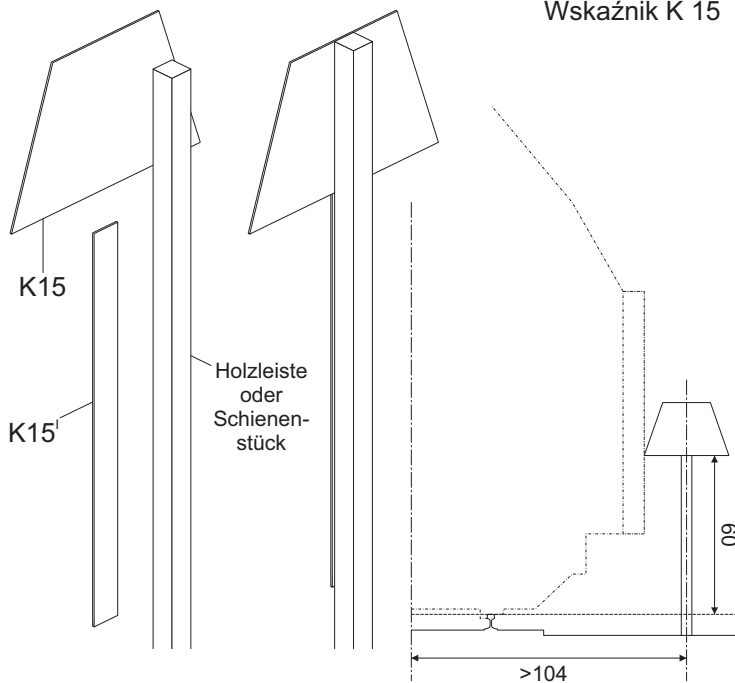

Wskaźnik K 16

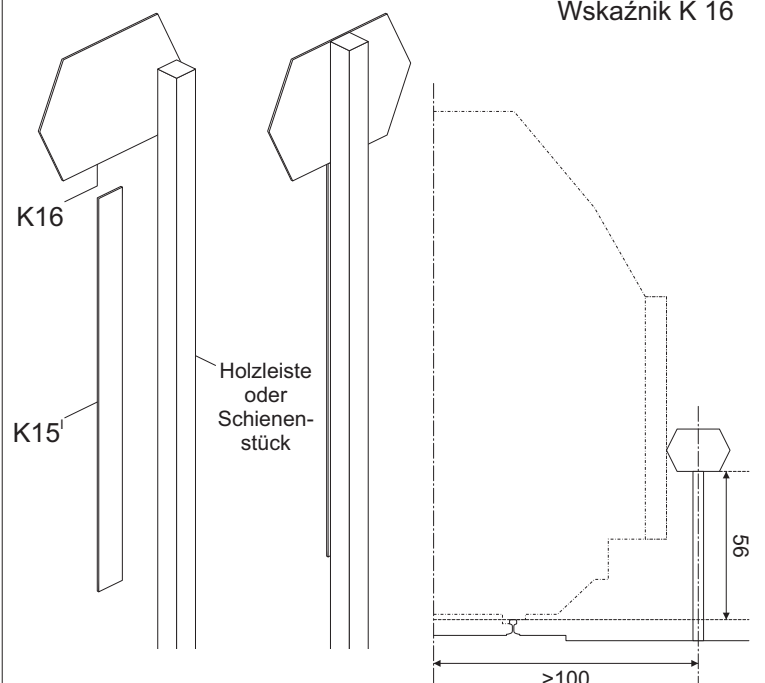

Variante: auslassen Teil K15' und streichen der Vorderseite des Pfahls schwarz/weiß schraggestreift an

Variante: auslassen Teil K15' und streichen der Vorderseite des Pfahls schwarz/weiß schraggestreift an

Signale und Kennzeichen der DRG/DR, 1935-1945, Maßstab 1:25

Bauanleitung 9/10

Bearbeitet bei Pawel Adamowicz (<http://pkprepo.net/>), 2021/2022, ausgewählte Rechte vorbehalten



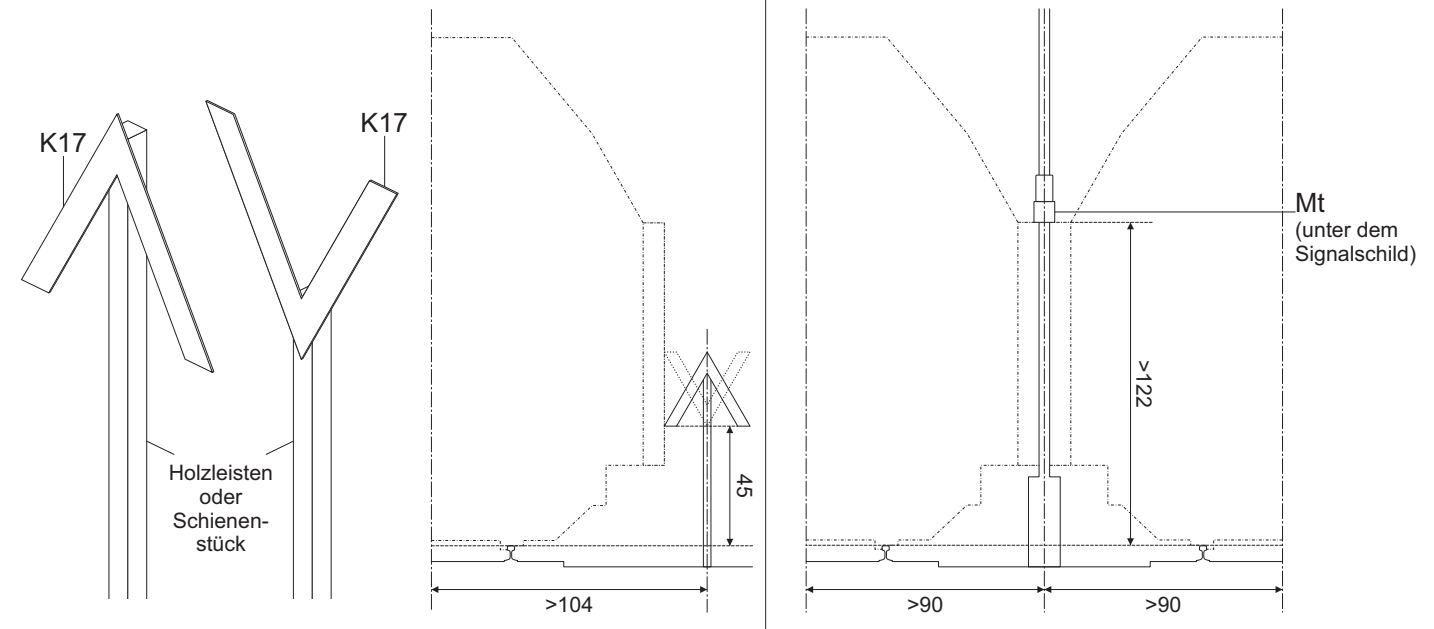

Fahrleitungssignale EI 1-EI 6, K 8b

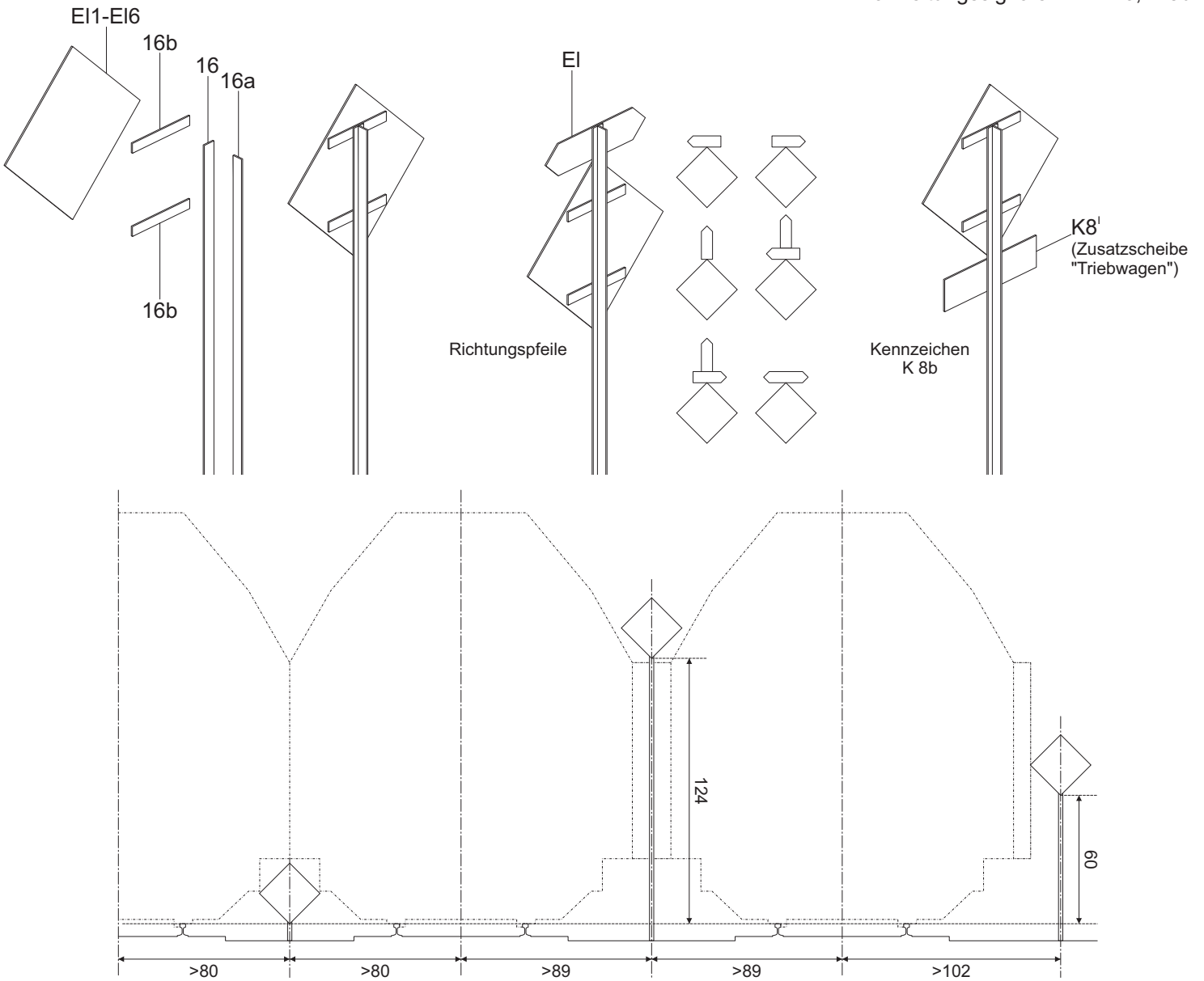

Signale und Kennzeichen der DRG/DR, 1935-1945, Maßstab 1:25

Bauanleitung 10/10